



Narrow Liquid Concentrate Iced Tea Dispensers



Style varies - Model TCC2N shown

READ AND SAVE THESE INSTRUCTIONS

NOTICE TO INSTALLER: Please leave this booklet with the machine.

Key Features/Specifications/System Requirements.....FS61

Important Safeguards..... IS2

Installation Instructions (General).....II28

Installation Instructions (Leveling, Water Supply).....II29

Operating InstructionsOI43

Cleaning Instructions..... CI25

Rough-In Drawing..... RD63

Illustrated Parts/Recommended Parts IP109

Troubleshooting GuideTG33

Product Warranty.....PW1

Contact Information

Wilbur Curtis Co., Inc.

6913 Acco Street | Montebello, CA 90640 US
Phone: 323-837-2300 | Toll Free: 800-421-6150
Email: cstrassistance@wilburcurtis.com | Web: www.wilburcurtis.com

For the latest specifications and information go to www.wilburcurtis.com
Toll Free: 800-995-0417 | Monday - Friday 5:30 A.M. - 4:00 P.M. PT
Email: techsupport@wilburcurtis.com

Due to continued product improvement, the products illustrated/photographed in this guide may vary slightly from the actual product.

Key Features

- Mixing chambers have been designed and engineered for enhanced blending performance
- Easily adjustable concentrate-to-water mixing ratio
- Drip tray and quick disconnect included
- Braided hoses
- Extra length hose for under-counter or remote bag-in-box applications

Specifications (Selected Models)

Physical

MODEL #	DESCRIPTION	CUP CLEARANCE	COMPARTMENT CAPACITY	REGULATOR SETTING	CONCENTRATE RATIO	CONCENTRATE CONNECTOR	DISPENSER FLOW RATE GAL/MIN
TCC1N	Single faucet	8.25"	4.0 gal. max.	15.0 psi	Adjustable	QCD2	0.6
TCC2N	Dual faucet	8.50"	2 x 2.0 gal. max.	15.0 psi	Adjustable	QCD2	0.6
TCC3N	Triple faucet	8.50"	3 x 1.0 gal. max.	15.0 psi	Adjustable	QCD2	0.6

Dimensions

Water Supply Requirements

MODEL #	HEIGHT	WIDTH	DEPTH	SHIP WEIGHT	SHIP CUBE	OPERATIONAL WEIGHT	WATER CONNECTOR	WATER PRESSURE	MIN. FLOW RATE
TCC1N	21.00"	6.25"	22.88"	20.0 lbs	6.18 cu ft	54.4 lbs	1/4" flare	20 - 90 psi	1.0 gpm
TCC2N	21.00"	6.25"	23.00"	21.0 lbs	6.18 cu ft	55.4 lbs	1/4" flare	20 - 90 psi	1.0 gpm
TCC3N	28.13"	9.38"	17.88"	22.0 lbs	6.18 cu ft	48.0 lbs	1/4" flare	20 - 90 psi	1.0 gpm

Symbols



This is the safety alert symbol. It is used to alert you to potential physical injury hazards. Obey all safety messages that follow this symbol to avoid possible injury or death.



DANGER - Indicates a hazardous situation which, if not avoided, will result in death or serious injury.



WARNING - Indicates a hazardous situation which, if not avoided, could result in death or serious injury.



CAUTION - Indicates a hazardous situation which, if not avoided, could result in minor or moderate injury.



NOTICE - Indicates a situation which, if not avoided, could result in property damage.



IMPORTANT - Provides information and tips for proper operation.



SANITATION REQUIREMENTS



WARNING - This product can expose you to chemicals including Acrylamide and Bisphenol A (BPA), which are known to the State of California to cause cancer and birth defects or other reproductive harm. For more information visit www.P65Warnings.ca.gov.

Important Safeguards/Conventions



WARNING:

- Make sure that this appliance is installed and grounded according to the INSTALLATION INSTRUCTIONS by qualified personnel before attempting to use it. Failure to follow the INSTALLATION INSTRUCTIONS could result in personal injury or void the warranty.
- This appliance is designed for commercial use. Any service other than cleaning and preventive maintenance should be performed by an authorized Wilbur Curtis service technician.
- To reduce the risk of fire or electric shock, DO NOT open the service panels. There are no user serviceable parts inside.
- Keep hands, arms and other items away from hot surfaces of the unit during operation.
- Clean the appliance and any dispensers completely before using them for the first time according to the CLEANING INSTRUCTIONS. Clean them regularly as instructed in the CLEANING INSTRUCTIONS.
- Use this appliance only for its intended use, brewing/dispensing hot and/or cold beverages/water.
- This appliance is not intended for use by persons (including children) with reduced physical, sensory or mental capabilities or lack of experience and knowledge, unless they have been given supervision or instruction concerning use of the appliance by a person responsible for their safety. Children should be supervised to ensure that they do not play with the appliance.
- Avoid spillage onto the power (mains) connector.

CE Requirements

- This appliance must be installed in locations where it can be overseen by trained personnel.
- For proper operation, this appliance must be installed where the temperature is between 5°C to 35°C.
- Appliance shall not be tilted more than 10° for safe operation.
- An electrician must provide electrical service as specified in conformance with all local and national codes. For safe use, an all-pole disconnection must be incorporated into the fixed wiring in accordance with the wiring rules outlined in clause 7.12.2 of IEC 60335 for meeting the minimum electrical safety of this standard.
- This appliance must not be cleaned by water jet.
- This appliance can be used by persons aged from 18 years and above if they have been given supervision or instruction concerning use of the appliance in a safe way and if they understand the hazards involved.
- Keep the appliance and its cord out of reach of children aged less than 18 years.
- Appliances can be used by persons 18 years and above with reduced physical, sensory or mental capabilities or lack of experience and knowledge if they have been given supervision or instruction concerning use of the appliance in a safe way and understand the hazards involved.
- Children under the age of 18 years should be supervised to ensure they do not play with the appliance.
- If the power cord is ever damaged, it must be replaced by the manufacturer or authorized service personnel with a special cord available from the manufacturer or its authorized service personnel in order to avoid a hazard.
- Machine must not be immersed for cleaning.
- Cleaning and user maintenance shall not be made by children unless they are older than 18 years and supervised.
- This appliance is intended to be used in household and similar applications such as:
 - staff kitchen areas in shops, offices and other working environments;
 - by clients in hotels, motels and other residential type environments;
 - bed and breakfast type environments.
- This appliance not intended to be used in applications such as:
 - farm houses
- Access to the service areas permitted by Authorized Service personnel only.
- The A-Weighted sound pressure level is below 70 dBA.



WARNING: Installation is to be performed only by a qualified installer.



NOTICE: DO NOT connect this appliance to a hot water supply. Do not exceed the maximum water pressure stated in the *SPECIFICATIONS* section.



IMPORTANT: Observe all governing codes and ordinances.

Installation Instructions

Installation Requirements

- A water filtration system is required to maintain trouble-free operation. Wilbur Curtis Co., Inc. recommends a Wilbur Curtis approved water filter. See the Curtis Equipment Catalog for a full line of Wilbur Curtis approved water filters.
- Potable water supply line connection from the water filter capable of supplying the minimum flow rate required by the specifications. The water supply line must be able to connect to the flare fitting on the back of the unit. See the *SPECIFICATIONS* section for the correct size. The water line should also be capable of being controlled by a shut off valve. Do not connect the water line to a saddle valve or needle valve.



NSF International requires the following water connection:

- 1 A quick disconnect or additional coiled tubing (at least two times the depth of the unit) is required so that it can be moved for cleaning underneath.
- 2 This equipment is to be installed with adequate back-flow protection to comply with applicable federal, state and local codes.
- 3 Water pipe connections and fixtures directly connected to a potable water supply shall be sized, installed and maintained in accordance with federal, state and local codes.

The International Plumbing Code of the International Code Council and the Food and Drug Administration (FDA) Food Code manual, direct that this equipment must be installed with adequate back-flow prevention in compliance with federal, state and local codes. For units installed outside of the U.S.A., make sure that the installation is in compliance with the applicable plumbing/sanitation code for your area.

Installation

Leveling

- 1 Position the unit on a level counter top capable of supporting its operating weight. See the *SPECIFICATIONS* section.

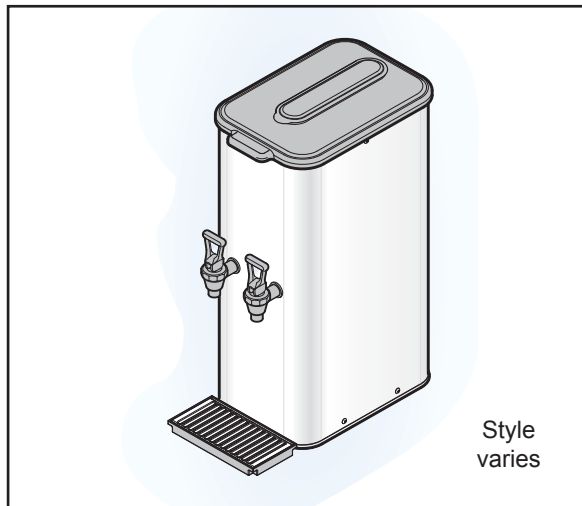

Connect the Water Supply

- 2 Make sure that the water supply valve on the back of the unit is in the OFF position.
- 3 Flush the water supply line before connecting it to the unit to purge air and debris from the water filter and tubing.

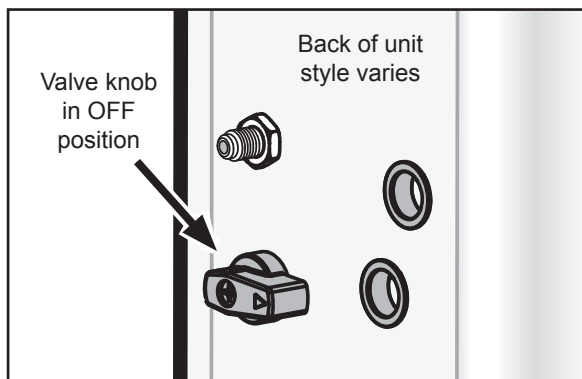

- 4 Connect the water supply line to the flare fitting on the back of the unit.
- 5 Open the water supply valve running to the unit. Also, turn the valve handle on the back of the unit itself to the ON position.
- 6 Sanitize the dispensing system according to the instructions in the *CLEANING INSTRUCTIONS* section before using the unit for the first time. While flushing out the system, check the connections on the incoming water line for leaks.

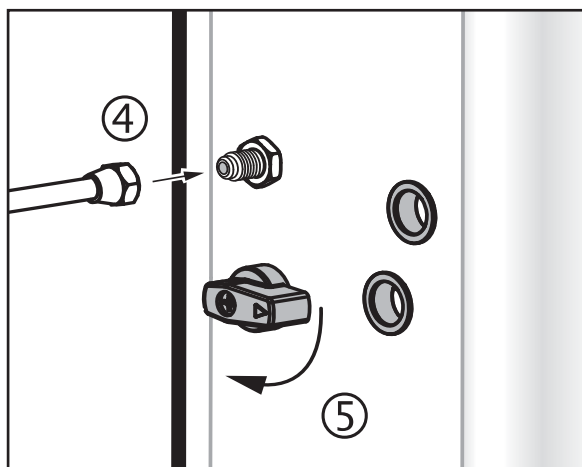

Use Instructions

WARNING - DO NOT refrigerate unused tea overnight for later consumption. Never hold dispensed tea for more than eight hours at room temperature. Discard any unused tea after eight hours.

NOTICE - Curtis strongly recommends that the water supply valve, behind the unit, be turned off during non-business hours.

The liquid concentrate tea/coffee dispenser is factory preset for optimal performance.

1 Make sure that the appropriate liquid concentrate bag(s) are connected to the unit. See the instructions below.

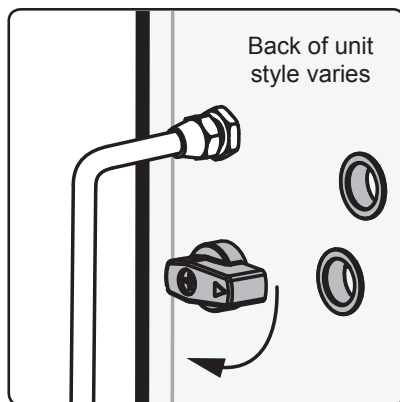

2 The main water supply and the water valve on the back of the unit should both be in the on position.

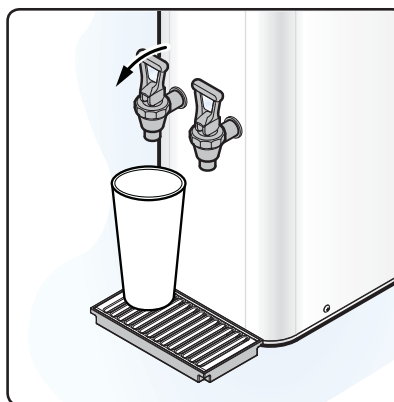

3 Hold a cup under the faucet and pull forward on the handle to dispense.

Changing/Attaching the Liquid Concentrate Bag

Reload the concentrate bag and re-prime the unit immediately when the bag is empty.

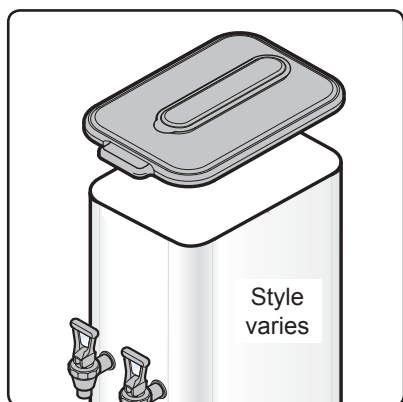

1 Remove the top cover from the TCC dispenser and pull the empty concentrate bag and hose out.

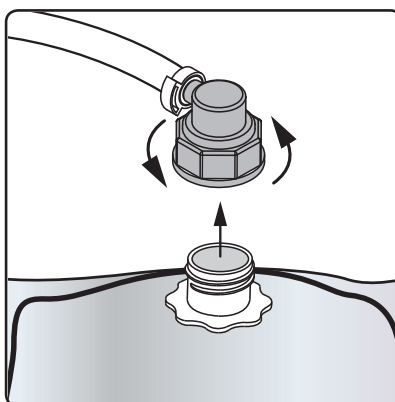

2 On units with a Scholle type connector, unscrew the connector from the bag and pull it up and off.

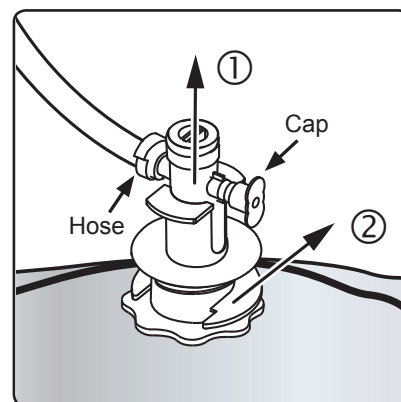

3 On units with a QCD type connector, release it by pulling up on the hose and cap assembly on the opposite sides. The plunger will pop up in the center of the QCD. Slide sideways to remove.

Changing/Attaching the Liquid Concentrate Bag (continued)

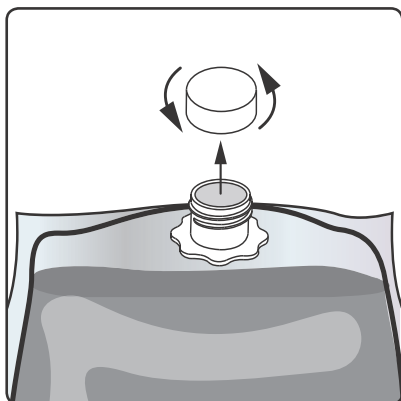

4 Place the new tea/coffee concentrate bag on the counter next to the TCC dispenser. Remove the shipping cap on the spout.

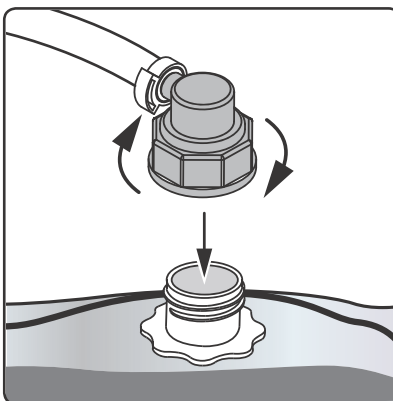

5 On units equipped with a Scholle type connector, place the connector over the bag spout and thread the connector all the way into the spout. Skip to step 8.

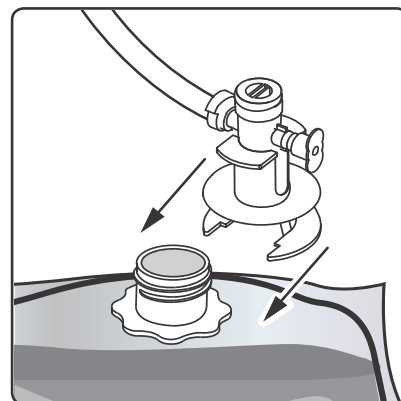

6 On units with a QCD connector, place the QCD next to the spout, then slide sideways until it stops.

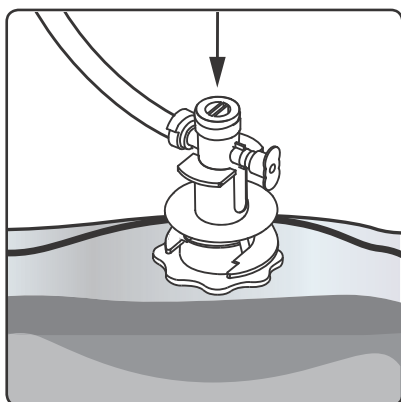

7 Push in on the QCD plunger until it snaps into place.

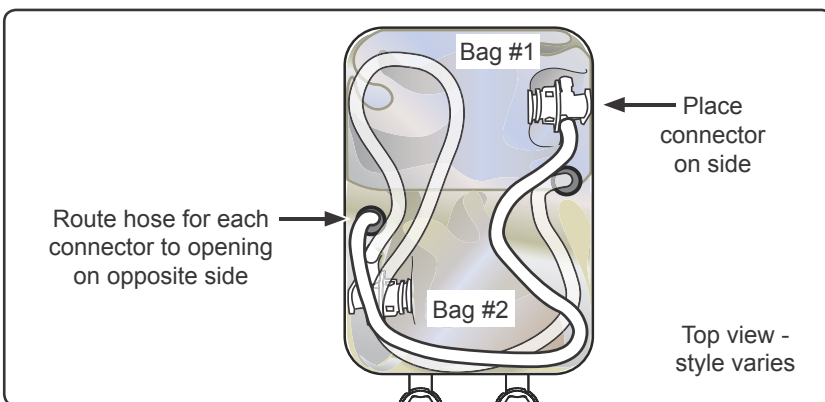

8 Carefully lift the bag and set it inside the dispenser. Rest the tubing on top of the bag. Route the tubing to the opposite product intake hole on the floor of dispenser, as shown.

9 Replace the top cover and dispense beverage from each faucet until darker product starts to appear (approximately 5 to 10 seconds).

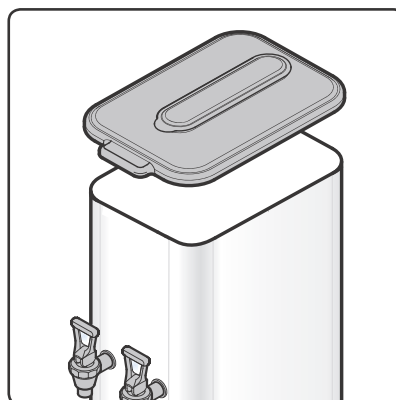

Mixing Valve Adjustment

- 1 Usually, the factory settings do not require adjustment. However, for customers who wish to adjust the flavor of the drink, the mixing valve changes the water to concentrate ratio. This valve is very sensitive. Only slight rotation of the mixing rod is needed to change the ratio (1/16th to 1/8th of a turn). The factory setting is approximately 7:1 ratio, which will result in a 5 to 8 percent brix when sweet tea concentrate is used.



NOTICE - Do not rotate the adjusting rod more than 2 full turns from the closed position. More turns will cause the adjustment rod to disengage from the mixing valve, resulting in a leak.

- 2 Tilt the dispenser on its side.
- 3 Before adjusting the mixing valve, check to make sure that the pressure regulator is set to 15 psi. If the regulator is not properly set, the mixing valve will not work properly. See *Setting the Pressure Regulator* for instructions.
- 4 Locate the adjusting rod (see diagram below). Turn it counter-clockwise (looking from the bottom) for a stronger concentration – turn clockwise for a weaker concentration. Taste the tea/coffee with each adjustment to determine the desired consistency.

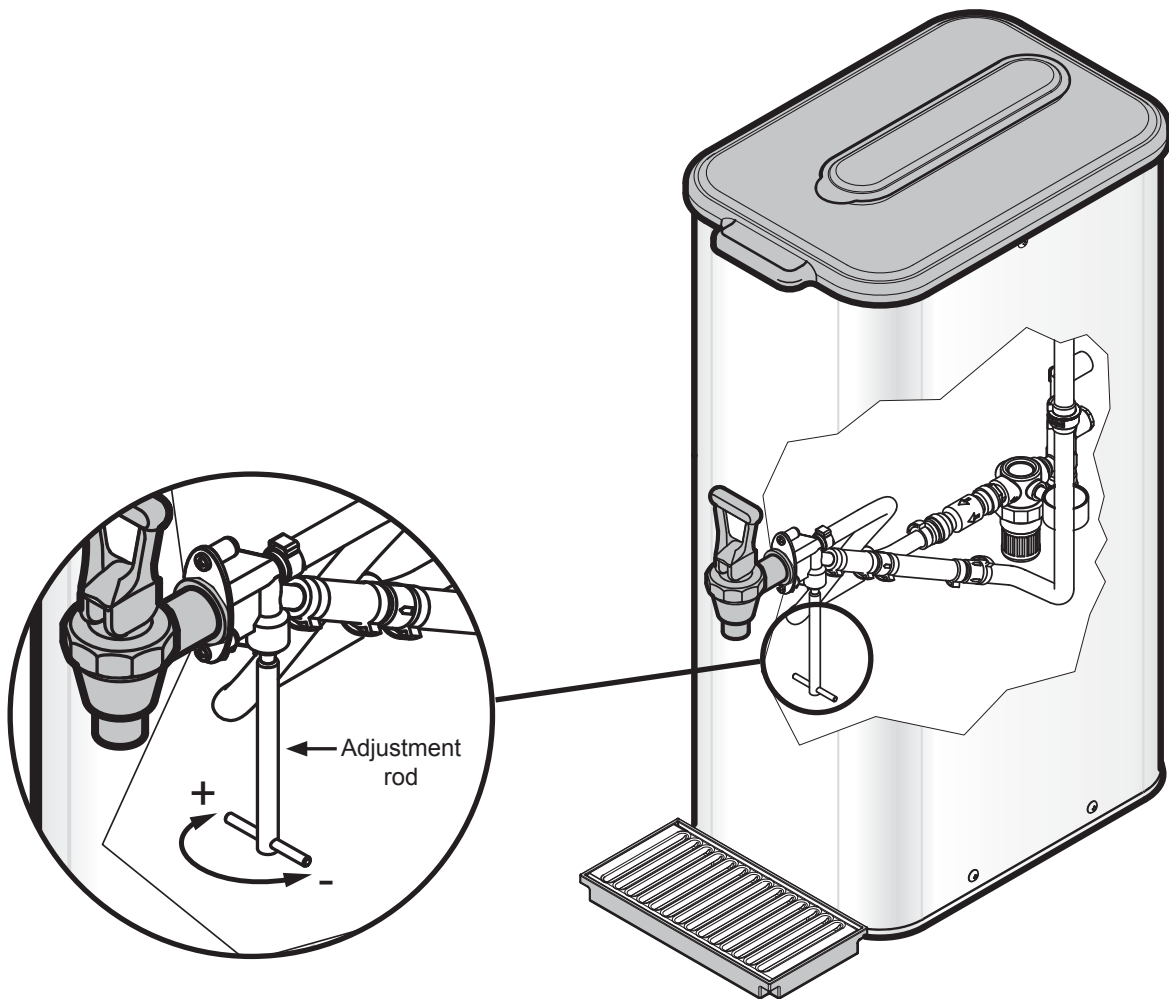

Setting the Pressure Regulator

! **NOTICE** - Do not exceed 25 psi (static). Equipment failure or leakage will result.

i **IMPORTANT** - Do not use the pressure regulator alone to adjust the taste/brix level. Confirm that the regulator is properly set, then adjust the taste/brix level using the *Mixing Valve Adjustment* instructions.

The purpose of the regulator is to provide uniform water pressure, so that the mixing valve can produce a stable and uniform blend of concentrate and water, and also to protect the hydraulics of the dispensing unit from excessive line pressure.

- 1 Tilt the dispenser on its side.
- 2 Locate the regulator adjustment knob and turn it until the pressure level on the gauge reads 15 psi.

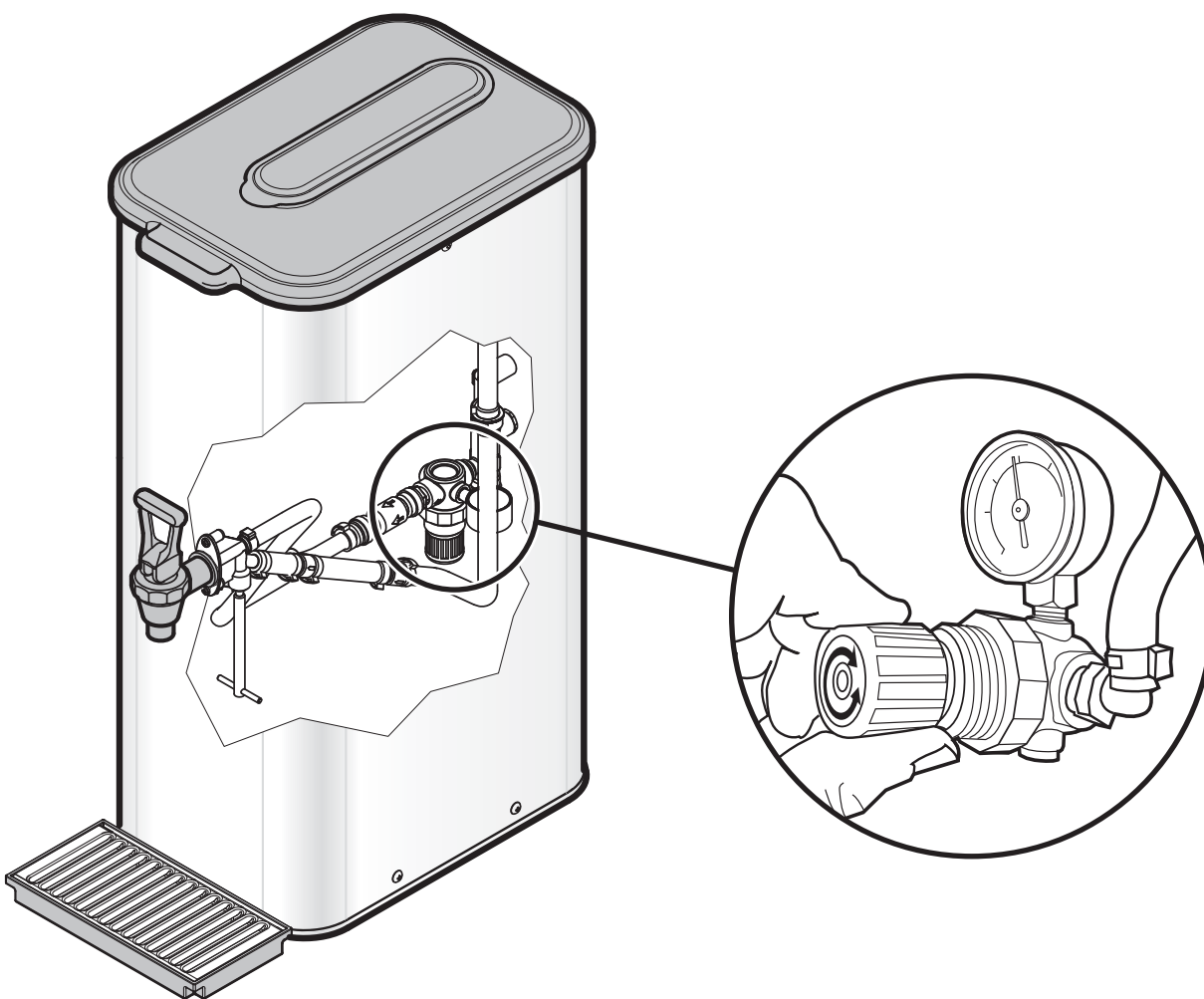

! **NOTICE** - Do not use cleaning liquids, compounds or powders containing chlorine (bleach) or corrosives. These products promote corrosion and will damage the finishes. **USE OF THESE PRODUCTS WILL VOID THE WARRANTY.** Do not immerse the unit in water or any other liquid.

Daily Cleaning

- 1 Prepare a mild cleaning solution of dish washing detergent and warm water.
- 2 Wipe any spills, dust or debris from the exterior surfaces, with a damp cloth. Apply a stainless steel polish to prevent scratches.
- 3 Turn off water supply at valve behind unit.
- 4 Open the dispensing faucet to relieve pressure in the dispensing lines.
- 5 Remove the top cover and clean with the cleaning solution.
- 6 Clean the faucet assembly:
 - Remove the handle/seat cup assembly from the faucet by holding the bonnet and unscrewing.
 - Clean the bonnet and silicone seat cup assembly.
 - Use a spiral brush soaked in cleaning solution to clean inside the faucet body.
 - Run the brush through the adapter on the body of the dispenser.
- 7 Rinse and dry parts that were removed. Assemble the dry parts onto the unit.

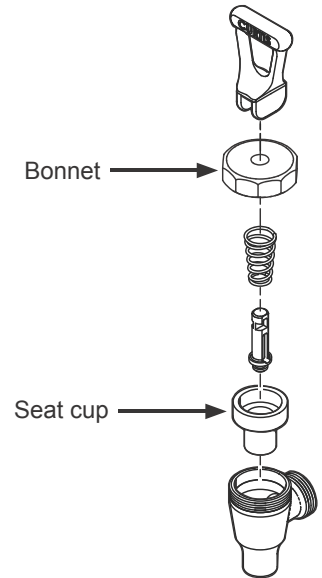

Weekly Cleaning and Sanitizing

Use a concentrated cleaning solution to simplify the cleaning procedure. This procedure requires a one gallon container of a cleaning solution containing hot water and a granulated concentrated cleaner (a cleaner like Coffee Dispenser Cleaner Corporation #12580, Urnex or equivalent) and a one gallon container of clean hot water.

- 1 Turn on water supply to the dispenser.
- 2 Remove the quick disconnect from the tea concentrate bag.
- 3 Pull the cap off of the QCD (see detail drawing) and place this end of the line into the container containing the cleaning solution.
- 4 Place a large empty container under the dispenser faucet.
- 5 Open the front faucet and dispense at least half of the cleaning solution.
- 6 Allow the dispenser to sit overnight before flushing cleaning solution.

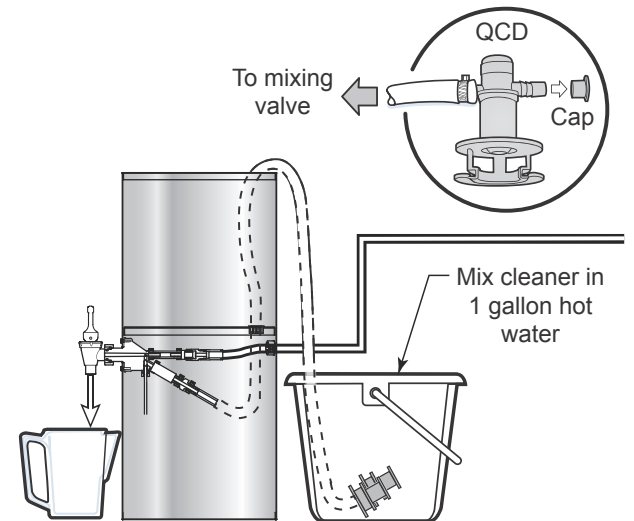

continued...

Weekly Cleaning and Sanitizing (cont.)

- 7 Flush the system by filling a one gallon container with clean hot water (no cleaning solution) and open the faucet and dispense at least one gallon of the hot water or until all the cleaning solution has been flushed from the system.
- 8 Remove the QCD from the flushing container and replace the cap. Reconnect the QCD to the Bag in the Box tea concentrate and dispense several cups to prime the concentrate line or until consistency of the product is correct.

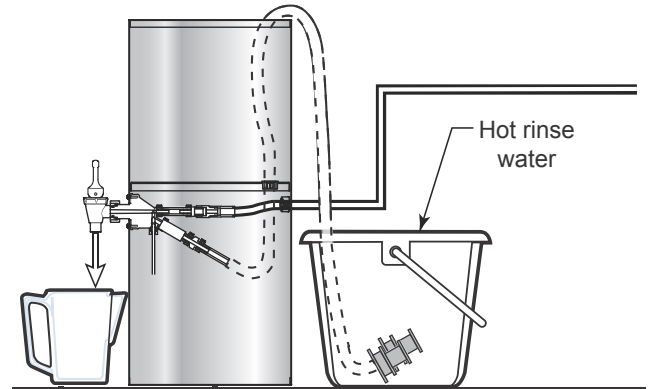

Sanitizing

Use a Bag-in-Box style cleaning solution to simplify the sanitizing procedure. A product like BevClean (<http://bevclean.com>) beverage line sanitizer comes in a 3 gallon bag-in-box that connects directly to your bag-in-box system for line sanitizing.

- 1 Remove the quick disconnect from the tea concentrate bag.
- 2 Place the BIB sanitizer container next to the TCC tea dispenser. Pull the spout from the sanitizer box through the marked area. Remove the clear travel cap from spout. Don't worry about spilling sanitizer when the cap is removed. The cap has an internal seal.
- 3 Snap the QCD bag connector onto the bag spout.
- 4 Grasping the bag connector (as shown in Load Product, step 6), push the sliding probe all the way into the bag spout. A "click" will be heard when it is fully inserted.
- 5 Once the cleaning solution box is connected, open the dispensing valve on the dispenser and run liquid through the valve until the sanitizer (clear liquid) is detected.

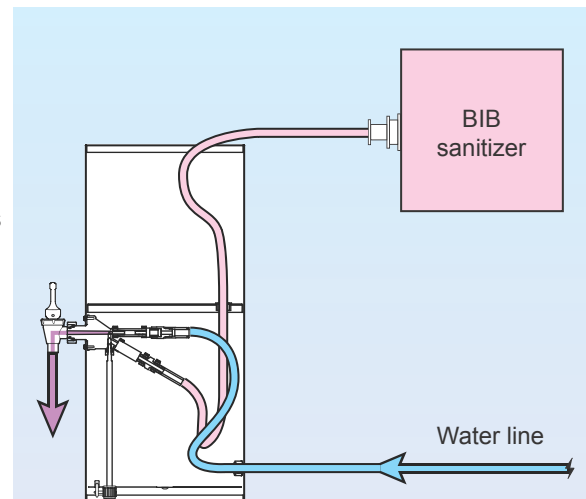

NSF DO NOT FLUSH. Allow the sanitizing solution to sit in the tea lines overnight before proceeding with line flushing steps 6 through 8, below.

- 6 Remove the QCD from the BIB cleaner. Unsnap the connector probe, pulling out and removing the connector from the spout.
- 7 Reattach the tea concentrate BIB product.
- 8 Open the dispensing faucet in front of the dispenser and allow water to run out until tea flows from the faucet.
- 9 Repeat the process for any additional faucets on dispenser.
- 10 Note: Multi-outlet manifolds are available for sanitizing up to eight beverage lines with one bag-in-box sanitizer. This allows you to clean all systems at one time.

Cleaning The Strainer - Monthly or As Needed

- 1 Turn off the water supply valve on the back of the unit. Open one of the dispensing faucets to relieve pressure in the tubing system.
- 2 Tilt the dispenser on its side.
- 3 Locate the strainer cap, located on the bottom of the water supply valve. Use a pair of pliers to grab the valve housing while removing the strainer cap with an adjustable wrench.
- 4 Remove the wire strainer and clean any debris out of the valve housing.
- 5 Use a spiral bristled brush to clean inside the strainer.
- 6 Rinse the strainer and reinsert it into the valve housing.
- 7 Replace the strainer cap.
- 8 Tilt the unit back into place and turn on the water supply valve.

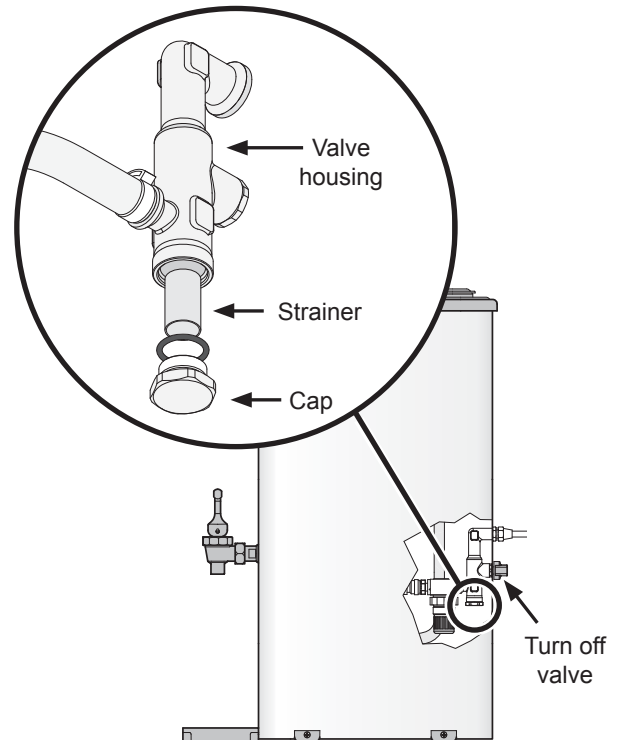

TCC1N

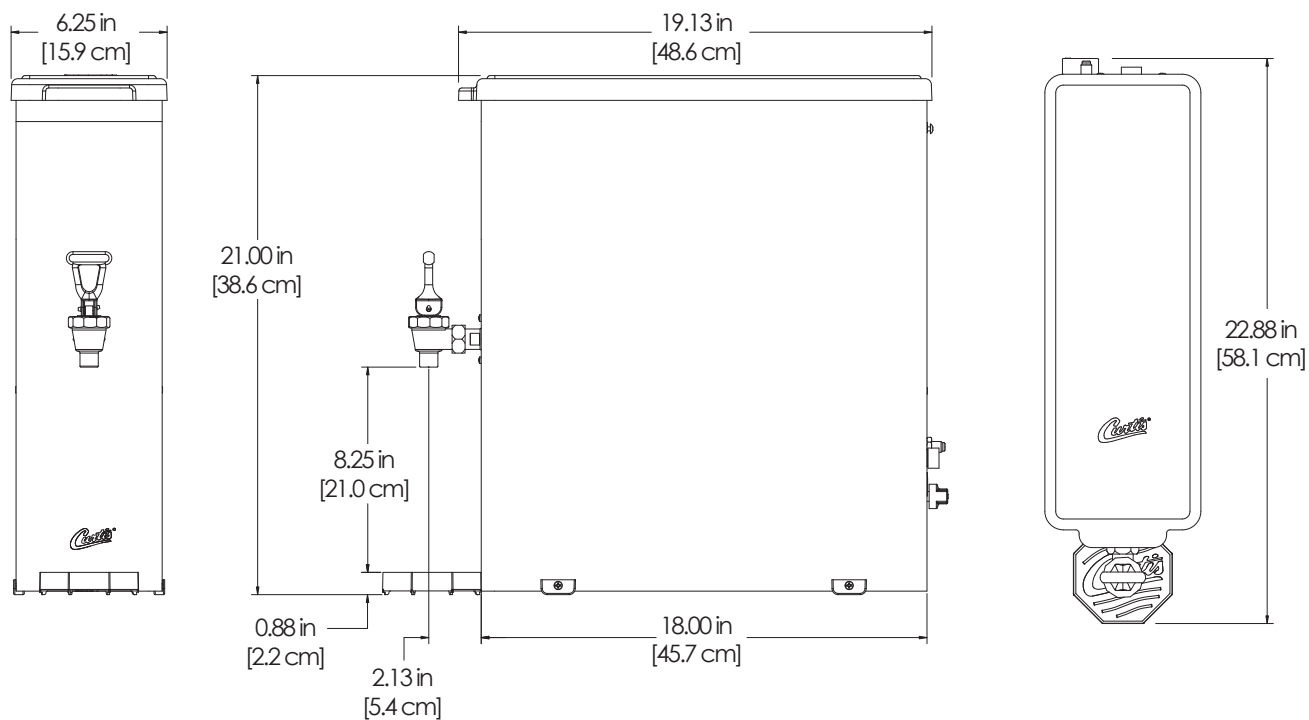

TCC2N

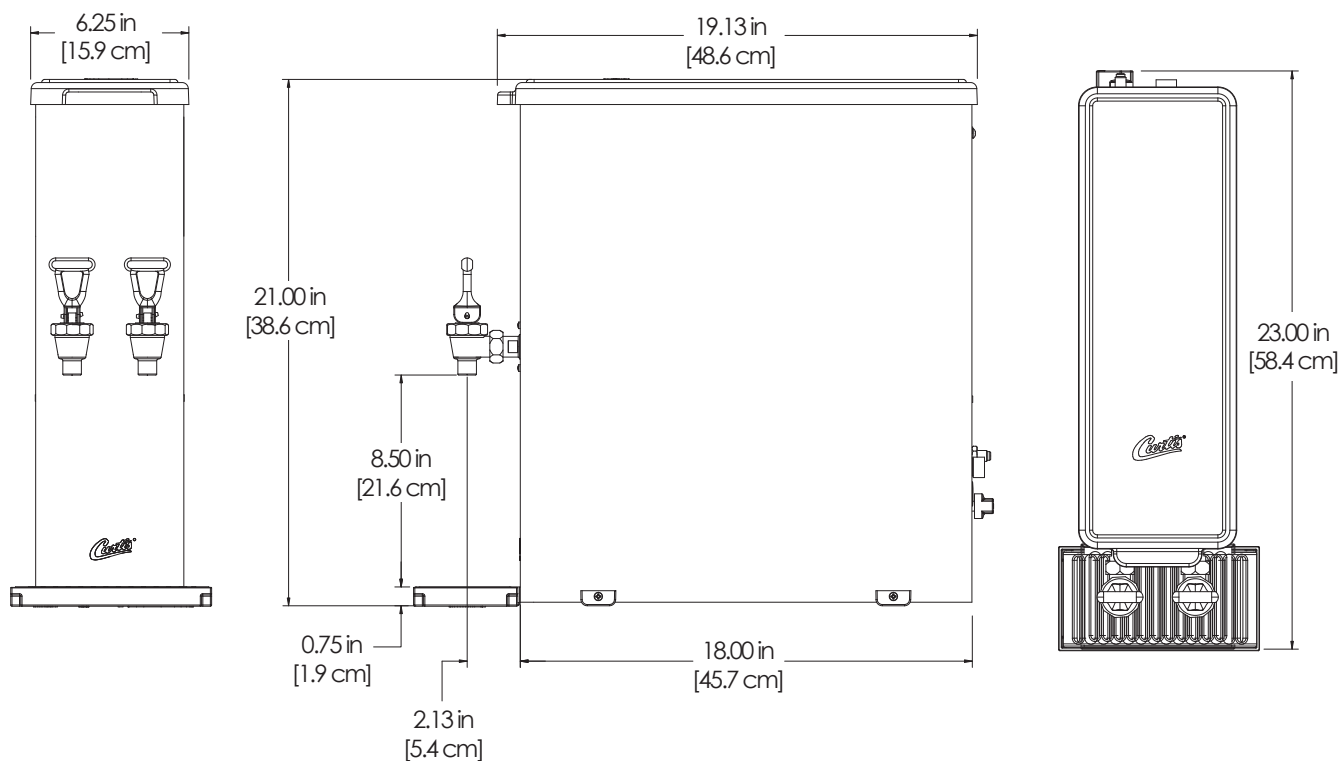

TCC3N

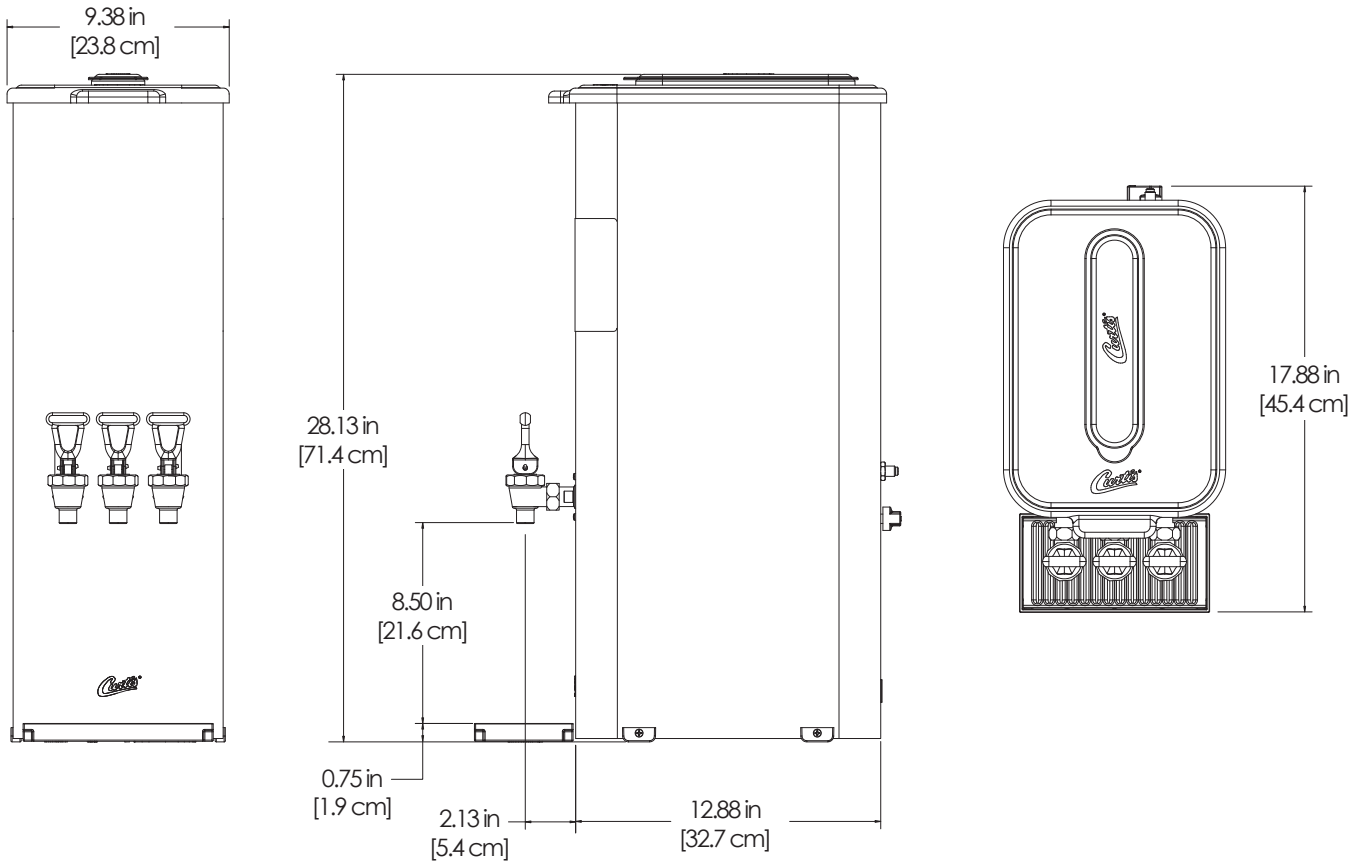

TCC1/2/3N - Outer Chassis - Exploded View

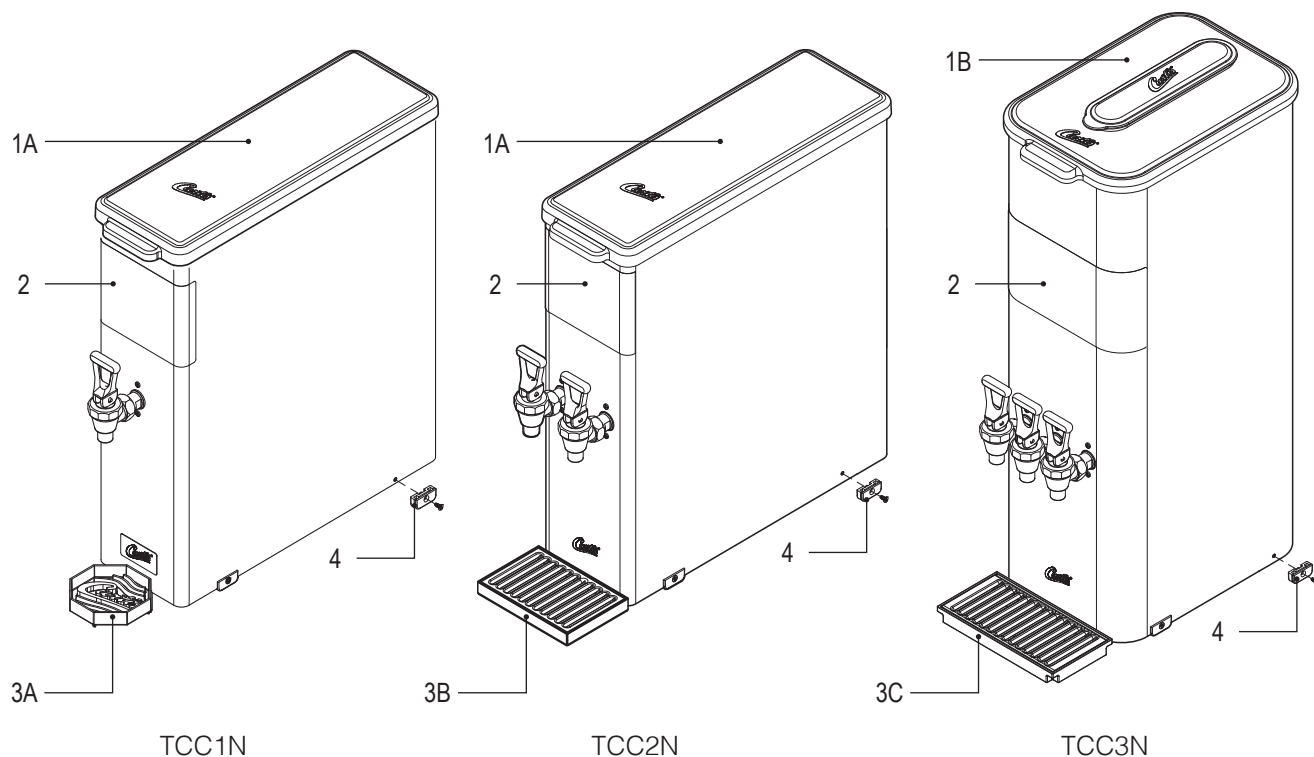

TCC1/2/3N - Outer Chassis - Parts List

ITEM #	PART #	DESCRIPTION
1A	WC-56043 ^{1,2}	LID, TCC1N
1B	WC-5683 ³	LID, SOLID/BREW-THRU (OPTIONAL USES) TCO'S
2	WC-38471	LABEL, FRONT TCO ICED TEA GENERIC

¹TCC1N, ²TCC2N, ³TCC3N

ITEM #	PART #	DESCRIPTION
3A	WC-5686 ¹	DRIP, TRAY OCTAGON STYLE
3B	DT-06 ²	DRIP TRAY, ASSY 6"
3C	DTP-08 ³	DRIP TRAY, ASSY PLASTIC 8"
4	WC-3531	LEG, PLASTIC GLIDE TCN

Recommended Parts to Stock

ITEM #	PART #	DESCRIPTION
1A	WC-56043	LID, TCC1N
1B	WC-5683	LID, SOLID/BREW-THRU (OPTIONAL USES) TCO'S

3A	WC-5686	DRIP, TRAY OCTAGON STYLE
3B	DT-06	DRIP TRAY, ASSY 6"
3C	DTP-08	DRIP TRAY, ASSY PLASTIC 8"

TCC1N Mixing/Dispensing System - Exploded View

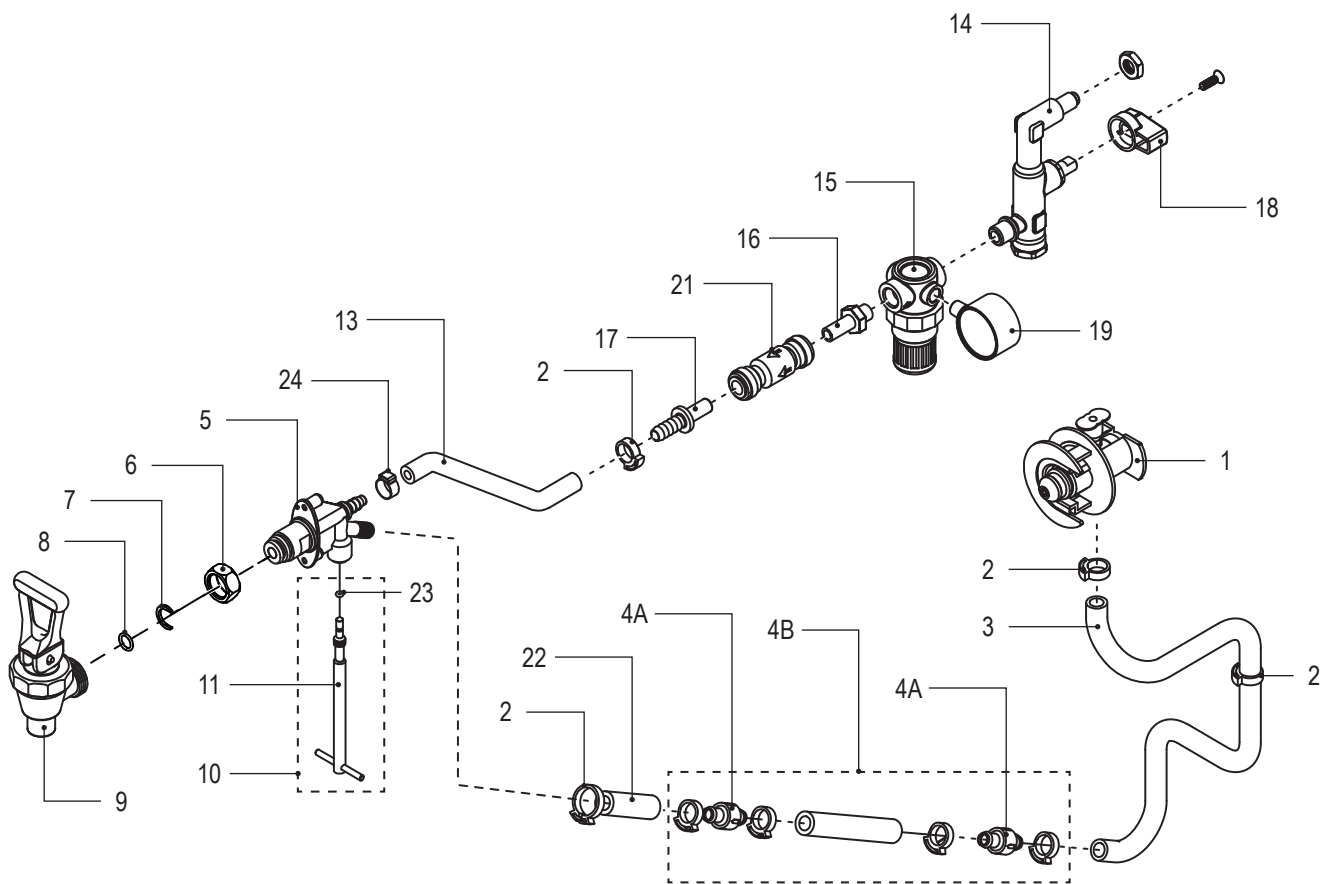

TCC2N Mixing/Dispensing System - Exploded View

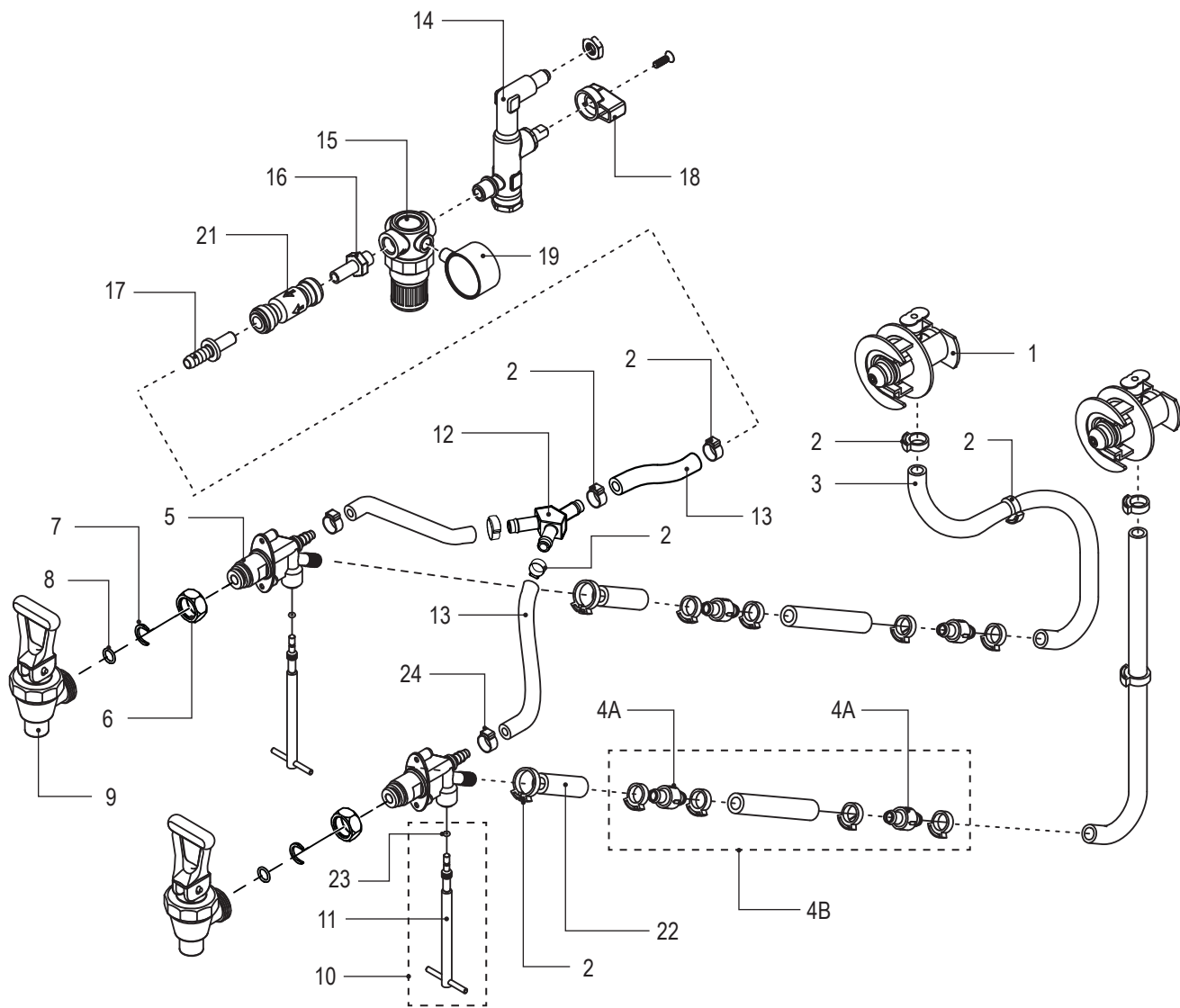

TCC3N Mixing/Dispensing System - Exploded View

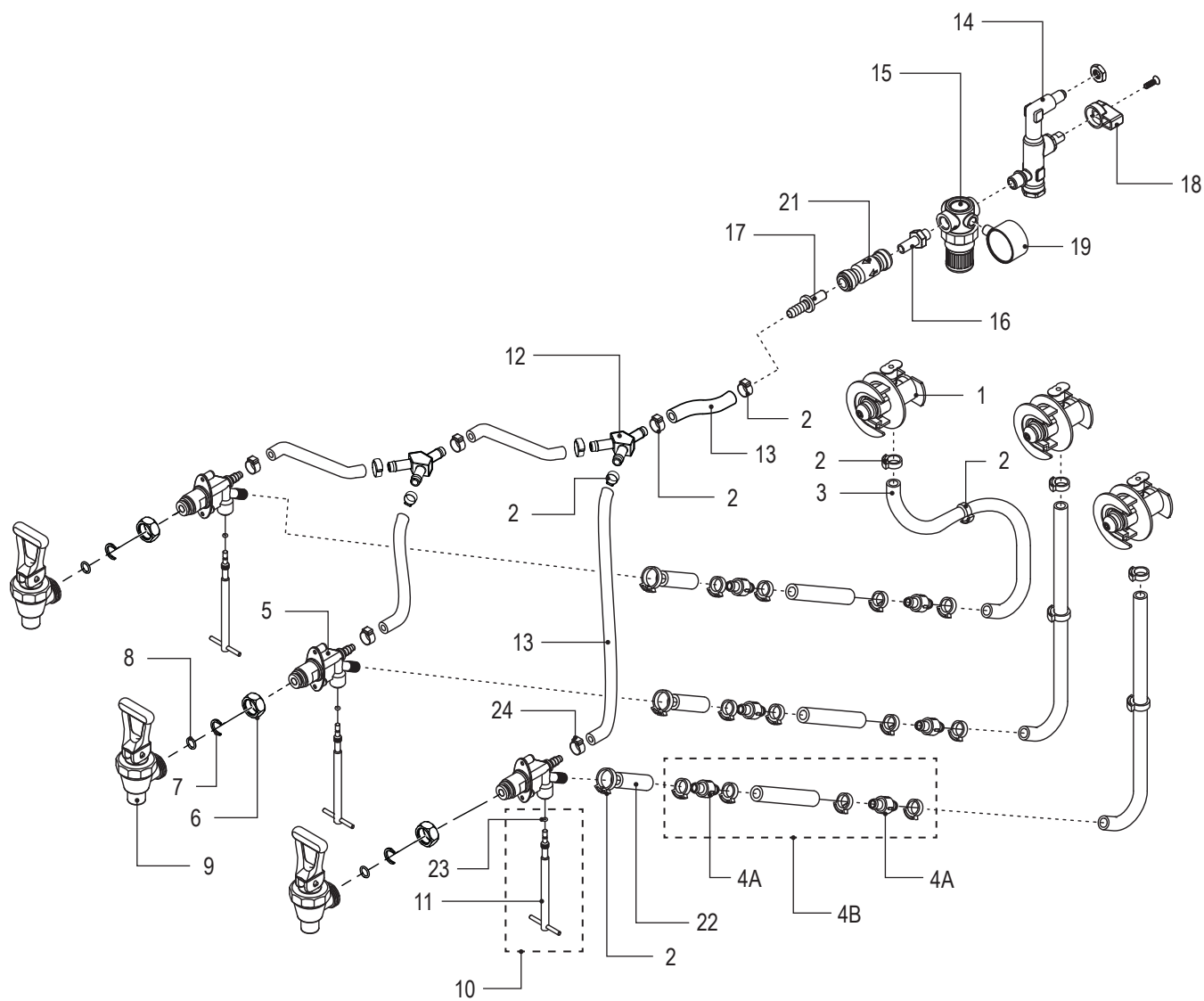

TCC1/2/3N Mixing/Dispensing System - Parts List

ITEM #	PART #	DESCRIPTION
1	WC-8653	QCD, LIQUID BOX BAG CONNECTOR TCC1/TCC2
2	WC-43002	CLAMP, HOSE SNAP NYLON .525/.605 TCC
3	WC-53116	TUBE, CLEAR BEV 5/8 O.D X 3/8 I.D SWEETENER SYSTEMS
4A	WC-37293	KIT, CHECK VALVE TCC (INCLUDES 2 CLAMPS)
4B	WC-37288	KIT, CHECK VALVE AND INSTRUCTIONS TCCS
5	WC-894	VALVE, MIXING TCC
6	WC-1903	NUT, UNION SHANK WB-10/ WB-10-60/WB-30-12
7	WC-1906	"C" RING .917 X .760 X .090 TT-3 TC'S
8	WC-4320	O'RING, 0.487I.D.x 0.693OD x0.103CS BUNA-N #112
9	WC-1829	FAUCET, ASSY TCC
10	WC-37312	KIT, ADJUSTING ROD & O-RING TCC'S FOR TEA
11	WC-29069	ROD, ADJUSTABLE MIXING VALVE TCC'S FOR TEA
12	WC-2219 ^{2,3}	Y- FITTING, BARBED 1/4X1/4X1/4 WHITE
13	WC-53113	TUBING, .25" ID X .50" OD BRAIDED SILICONE 60 DUROMETER

¹TCC1N, ²TCC2N, ³TCC3N

ITEM #	PART #	DESCRIPTION
14	WC-12011	VALVE, STRAINER ANGLED ALL TCC'S
15	WC-811-101	REGULATOR, PRESSURE 1/4" 0-50 PSIG PLASTIC
16	WC-2451	ADAPTER, 3/8 OD STEM X 1/4 NPTF JOHN GUEST
17	WC-2445	STEM, 3/8 BARB X 3/8 STEM SWEETENER SYSTEMS
18	WC-12011-101	CAP, HANDLE PLASTIC ALL TCC'S
19	WC-569	GAUGE, REGULATOR 0-30 PSI
20	WC-43059	CLAMP, HOSE SNAP NYLON .616/.707
21	WC-2452	VALVE, CHECK 3/8 OD TUBE X 3/8 OD TUBE JOHN GUEST
22	WC-53114	TUBING, .375" ID X .625" OD X 10ft BRD SILICONE 60 DUROMETER
23	WC-43084	O'RING, .070" ID X .070W BUNA-N TCC1/TCC2
24	WC-14022	CLAMP, TUBING 15.3-18.5mm SS OETIKER

Recommended Parts to Stock

ITEM #	PART #	DESCRIPTION
1	WC-8653	QCD, LIQUID BOX BAG CONNECTOR TCC1/TCC2
3	WC-53116	TUBE, CLEAR BEV 5/8 O.D X 3/8 I.D SWEETENER SYSTEMS
4A	WC-37293	KIT, CHECK VALVE TCC
4B	WC-37288	KIT, CHECK VALVE AND INSTRUCTIONS TCCS
5	WC-894	VALVE, MIXING TCC
6	WC-1903	NUT, UNION SHANK WB-10/ WB-10-60/WB-30-12
7	WC-1906	"C" RING .917 X .760 X .090 TT-3 TC'S
8	WC-4320	O'RING, 0.487I.D.x 0.693OD x0.103CS BUNA-N #112
9	WC-1829	FAUCET, ASSY TCC

ITEM #	PART #	DESCRIPTION
12	WC-2219	Y- FITTING, BARBED 1/4X1/4X1/4 WHITE
13	WC-53113	TUBING, .25" ID X .50" OD BRAIDED SILICONE 60 DUROMETER
19	WC-569	GAUGE, REGULATOR 0-30 PSI
22	WC-53114	TUBING, .375" ID X .625" OD X 10ft BRD SILICONE 60 DUROMETER
23	WC-43084	O'RING, .070" ID X .070W BUNA-N TCC1/TCC2

Troubleshooting Guidelines

This troubleshooting guide identifies some, but not all, of the possible causes for common problems that can occur.

Nothing Comes Out of the Faucet

- 1 Check to make sure that both the water supply valve for the water supply line and the valve on the back of the unit are turned on.
- 2 Check for a clogged water supply filter.

Only Water Flows from the Faucet, Not Tea/Coffee

- 1 Check to make sure that the concentrate bag is not empty.
- 2 Check to make sure that the concentrate supply hose is not kinked or blocked. Trace the hose all the way from the concentrate bag to the mixing valve.
- 3 Check to make sure that the mixing valve is not completely closed. If it is, turn it 1/4 counter-clockwise (looking from the bottom of the unit).
- 4 Check to see if the check valve in the concentrate line is stuck closed.

Tea/Coffee is Weak

- 1 Check to see if the mixing valve is out of adjustment. *See Mixing Valve Adjustment* in the *OPERATING INSTRUCTIONS*.
- 2 Check to see if the check valve in the concentrate line is stuck closed. Check to make sure that the valve is installed in the correct orientation (arrow must point in direction of flow).

Tea/Coffee Coming from the Faucet is Foamy or Bubbly

- 1 Make sure all air is purged from the concentrate bag.
- 2 Check the O-ring/gasket on the concentrate bag connector. A worn out O-ring/gasket can allow air to be sucked into the hose.
- 3 Check for loose clamps on the concentrate hose. All clamps must be tight. Check all of the clamps tracing from the concentrate bag to the mixing valve.

Faucet Drips Constantly

- 1 Check for a worn or dirty faucet seat cup. See *CLEANING INSTRUCTIONS*.
- 2 Check to make sure that the pressure regulator is set to 15 psi. If the regulator cannot be adjusted down to 15 psi, check to make sure that the incoming pressure does not exceed 90 psi. If it does, an external pressure regulator may be required to lower the incoming pressure. If the pressure going into the regulator is within specifications (less than 90 psi), but cannot be adjusted down to 15 psi, the regulator is probably defective.

Wilbur Curtis Co., Inc. certifies that its products are free from defects in material and workmanship under normal use. The following limited warranties and conditions apply:

- 3 years, parts and labor, from original date of purchase on digital control boards
- 2 years, parts, from original date of purchase on all other electrical components, fittings and tubing
- 1 year, labor, from original date of purchase on all other electrical components, fittings and tubing

Additionally, Wilbur Curtis Co., Inc. warrants its grinding burrs for forty (40) months from the date of purchase or 40,000 pounds of coffee, whichever comes first. Stainless steel components are warranted for two (2) years from the date of purchase against leaking or pitting. Replacement parts are warranted for ninety (90) days from the date of purchase or for the remainder of the limited warranty period of the equipment in which the component is installed.

All in-warranty service calls must have prior authorization. For authorization, call the Technical Support Department at 800-995-0417. Additional conditions may apply. Go to www.wilburcurtis.com to view the full product warranty information.

CONDITIONS & EXCEPTIONS

The warranty covers original equipment at time of purchase only. Wilbur Curtis Co., Inc., assumes no responsibility for substitute replacement parts installed on Curtis equipment that have not been purchased from Wilbur Curtis Co., Inc. Wilbur Curtis Co., Inc. will not accept any responsibility if the following conditions are not met. The warranty does not cover:

- **Adjustments and cleaning:** *The resetting of safety thermostats and circuit breakers, programming and temperature adjustments are the responsibility of the equipment owner. The owner is responsible for proper cleaning and regular maintenance of this equipment.*
- **Replacement of items subject to normal use and wear:** *This shall include, but is not limited to, spray heads, faucets, light bulbs, shear disks, "O" rings, gaskets, silicone tubing, silicone elbows, canister assemblies, whipper chambers and plates, mixing bowls, agitation assemblies and whipper propellers.*

The warranty is void under the following circumstances:

- **Improper operation of equipment:** *The equipment must be used for its designed and intended purpose and function.*
- **Improper installation of equipment:** *This equipment must be installed by a professional technician and must comply with all local electrical, mechanical and plumbing codes.*
- **Improper voltage:** *Equipment must be installed at the voltage stated on the serial plate supplied with this equipment.*
- **Improper water supply:** *This includes, but is not limited to, excessive or low water pressure and inadequate or fluctuating water flow rate.*
- **Damaged in transit:** *Equipment damaged in transit is the responsibility of the freight company and a claim should be made with the carrier.*
- **Abuse or neglect (including failure to periodically clean or remove lime accumulations):** *The manufacturer is not responsible for variation in equipment operation due to excessive lime or local water conditions. The equipment must be maintained according to the manufacturer's recommendations.*

Repairs and/or Replacements are subject to Curtis' decision that the workmanship or parts were faulty and the defects showed up under normal use. All labor shall be performed during regular working hours. Overtime charges are the responsibility of the owner. Charges incurred by delays, waiting time, or operating restrictions that hinder the service technician's ability to perform service is the responsibility of the owner of the equipment. This includes institutional and correctional facilities. Wilbur Curtis Co., Inc. will allow up to 100 miles, round trip, per in-warranty service call.

Return Merchandise Authorization (RMA): All claims under this warranty must be submitted to the Wilbur Curtis Technical Support Department prior to performing any repair work or return of this equipment to the factory. **All returned equipment must be properly re-packaged in the original carton and received by Curtis within 45 days following the issuance of a RMA.** No units will be accepted if they are damaged in transit due to improper packaging. **NO UNITS OR PARTS WILL BE ACCEPTED WITHOUT A RETURN MERCHANDISE AUTHORIZATION (RMA). THE RMA NUMBER MUST BE MARKED ON THE CARTON OR SHIPPING LABEL. All warranty claims must be submitted within 60 days of service. Invoices will not be processed or accepted without a RMA number. Any defective parts must be returned in order for warranty invoices to be processed and approved.** All in-warranty service calls must be performed by an authorized service agent. Call the Wilbur Curtis Technical Support Department to find an agent near you.