



WELLS BLOOMFIELD, LLC
10 Sunnen Dr., St. Louis, MO 63143
telephone: 888-356-5362
fax: 314-781-2714
www.wells-mfg.com



Model F14



Model F55



Model F85



Model F1725

OWNERS MANUAL

STANDARD FRYERS

COUNTERTOP MODELS

F14

F49

F55

F67

F85

F1725

Includes
**INSTALLATION
USE & CARE
EXPLODED VIEW
PARTS LIST
WIRING DIAGRAM**

IMPORTANT: DO NOT DISCARD THIS MANUAL

This manual is considered to be part of the appliance and is to be given to the OWNER or MANAGER of the restaurant, or to the person responsible for TRAINING OPERATORS of this appliance. Additional manuals are available from your WELLS DEALER.

THIS MANUAL MUST BE READ AND UNDERSTOOD BY ALL PERSONS USING OR INSTALLING THIS APPLIANCE. Contact your WELLS DEALER if you have any questions concerning installation, operation or maintenance of this equipment.



LIMITED WARRANTY STATEMENT

Unless otherwise specified, all commercial cooking equipment manufactured by WELLS BLOOMFIELD, LLC is warranted against defects in materials and workmanship for a period of one year from the date of original installation or 18 months from the date of shipment from our factory, whichever comes first, and is for the benefit of the original purchaser only.

THIS WARRANTY IS THE COMPLETE AND ONLY WARRANTY, EXPRESSED OR IMPLIED IN LAW OR IN FACT, INCLUDING BUT NOT LIMITED TO, WARRANTIES OF MERCHANTABILITY OR FITNESS FOR ANY PARTICULAR PURPOSE, AND/OR FOR DIRECT, INDIRECT OR CONSEQUENTIAL DAMAGES IN CONNECTION WITH WELLS BLOOMFIELD PRODUCTS. This warranty is void if it is determined that, upon inspection by an authorized service agency, the equipment has been modified, misused, misapplied, improperly installed, or damaged in transit or by fire, flood or act of God. It also does not apply if the serial nameplate has been removed, or if service is performed by unauthorized personnel. The prices charged by Wells Bloomfield for its products are

based upon the limitations in this warranty. Seller's obligation under this warranty is limited to the repair of defects without charge by a Wells Bloomfield factory authorized service agency or one of its sub-service agencies. This service will be provided on customer's premises for non-portable models. Portable models (a device with a cord and plug) must be taken or shipped to the closest authorized service agency, transportation charges prepaid, for service. In addition to restrictions contained in this warranty, specific limitations are shown in the Service Policy and Procedure Guide. Wells Bloomfield authorized service agencies are located in principal cities. This warranty is valid in the United States and Canada and void elsewhere. Please consult your classified telephone directory, your foodservice equipment dealer or contact:

Wells Bloomfield, LLC

**10 Sunnen Dr., P.O.Box 430129 St. Louis MO 63143 USA
phone (314) 781-2777 or fax (314) 781-2714**

for information and other details concerning warranty.

SERVICE POLICY AND PROCEDURE GUIDE and ADDITIONAL WARRANTY EXCLUSIONS

1. Resetting of safety thermostats, circuit breakers, over load protectors, and/or fuse replacements are **not** covered by this warranty unless warranted conditions are the cause.
2. All problems due to operation at **voltages or phase other than specified on equipment nameplates** are **not** covered by this warranty. Conversion to correct voltage and/or phase must be the customer's responsibility.
3. All problems due to **electrical connections not made in accordance with electrical code requirements and wiring diagrams** supplied with the equipment are **not** covered by this warranty.
4. Replacement of items **subject to normal wear**, to include such items as knobs, light bulbs; and, normal maintenance functions including adjustments of thermostats, adjustment of micro switches and replacement of fuses and indicating lights are **not** covered by warranty.
5. Damage to electrical cords and/or plug due to exposure to excessive heat are **not** covered by this warranty.
6. Full use, care, and maintenance instructions supplied with each machine. Noted maintenance and preventative maintenance items, such as servicing and cleaning schedules, are customer responsibility. Those miscellaneous adjustments noted are customer responsibility. Proper attention to preventative maintenance and scheduled maintenance procedures will prolong the life of the appliance.
7. Travel mileage is limited to **sixty (60) miles** from an Authorized Service Agency or one of its sub-service agencies.
8. All labor shall be performed during regular working hours. Overtime premium will be charged to the buyer.
9. All genuine Wells replacement parts are warranted for ninety (90) days from date of purchase on non-warranty equipment. This parts warranty is limited only to replacement of the defective part(s). **Any use of non-genuine Wells parts completely voids any warranty.**
10. Installation, labor, and job check-outs are **not** considered warranty and are thus **not** covered by this warranty.
11. Charges incurred by delays, waiting time or operating restrictions that hinder the service technician's ability to perform service are **not** covered by warranty. This includes institutional and correctional facilities.

SHIPPING DAMAGE CLAIM PROCEDURE

NOTE: For your protection, please note that equipment in this shipment was carefully inspected and packaged by skilled personnel before leaving the factory. Upon acceptance of this shipment, the transportation company assumes full responsibility for its safe delivery.

IF SHIPMENT ARRIVES DAMAGED:

1. **VISIBLE LOSS OR DAMAGE:** Be certain that any visible loss or damage is noted on the freight bill or express receipt, and that the note of loss or damage is signed by the delivery person.
2. **FILE CLAIM FOR DAMAGE IMMEDIATELY:** Regardless of the extent of the damage.

3. **CONCEALED LOSS OR DAMAGE:** if damage is unnoticed until the merchandise is unpacked, notify the transportation company or carrier immediately, and file "CONCEALED DAMAGE" claim with them. This should be done within fifteen (15) days from the date the delivery was made to you. Be sure to retain the container for inspection.

Wells Bloomfield cannot assume liability for damage or loss incurred in transit. We will, however, at your request, supply you with the necessary documents to support your claim.

TABLE OF CONTENTS

WARRANTY	xi
SPECIFICATIONS	1
FEATURES & OPERATING CONTROLS	2
PRECAUTIONS & GENERAL INFORMATION	3
AGENCY LISTING INFORMATION	4
INSTALLATION	4
OPERATION	6
CLEANING INSTRUCTIONS	7
TROUBLESHOOTING SUGGESTIONS	9
MAINTENANCE	10
EXPLODED VIEW & PARTS LIST	11
WIRING DIAGRAM	18
PARTS & SERVICE	25
CUSTOMER SERVICE DATA	25

INTRODUCTION

Thank You for purchasing this Wells Bloomfield appliance.

Proper installation, professional operation and consistent maintenance of this appliance will ensure that it gives you the very best performance and a long, economical service life.

This manual contains the information needed to properly install this appliance, and to use and care for the appliance in a manner which will ensure its optimum performance.

SPECIFICATIONS

MODEL	VOLTS	AMPS	WATTS	POWER SUPPLY CORD
F14	120 VAC 1 \emptyset	15A	1.8KW	NEMA 5-15P
	208/240 VAC 1 \emptyset	16.4/18.8A	3.4/4.5KW	NEMA 6-30P
F49	208 VAC 1 \emptyset	22.1 A	4.6KW	NEMA 6-30P
	208/240 VAC 1 \emptyset	16.6/19.1A	3.5/4.6KW	
F55	208VAC 1 \emptyset	27.7A	5.75KW	NOT SUPPLIED
	240VAC 1 \emptyset	24.0A	5.75KW	
F67	208VAC 3 \emptyset	L1=38.3A L2=22.1A L3=22.1A	9.2KW	NOT SUPPLIED
	208/240VAC 3 \emptyset	L1=28.8/33.2A L2=16.6/19.2A L3=16.6/19.2A	6.9/9.2KW	
F85	208VAC 3 \emptyset	L1=31.9A L2=31.9A L3=31.9A	11.5KW	NOT SUPPLIED
	240VAC 3 \emptyset	L1=27.6A L2=27.6A L3=27.6A	11.5KW	
	480VAC 3 \emptyset	L1=13.8A L2=13.8A L3=13.8A	11.5KW	
F1725	208VAC 3 \emptyset	L1=47.8A L2=47.8A L3=47.8A	17.25KW	NOT SUPPLIED
	240VAC 3 \emptyset	L1=41.5A L2=41.5A L3=41.5A	17.25KW	

FEATURES & OPERATING CONTROLS

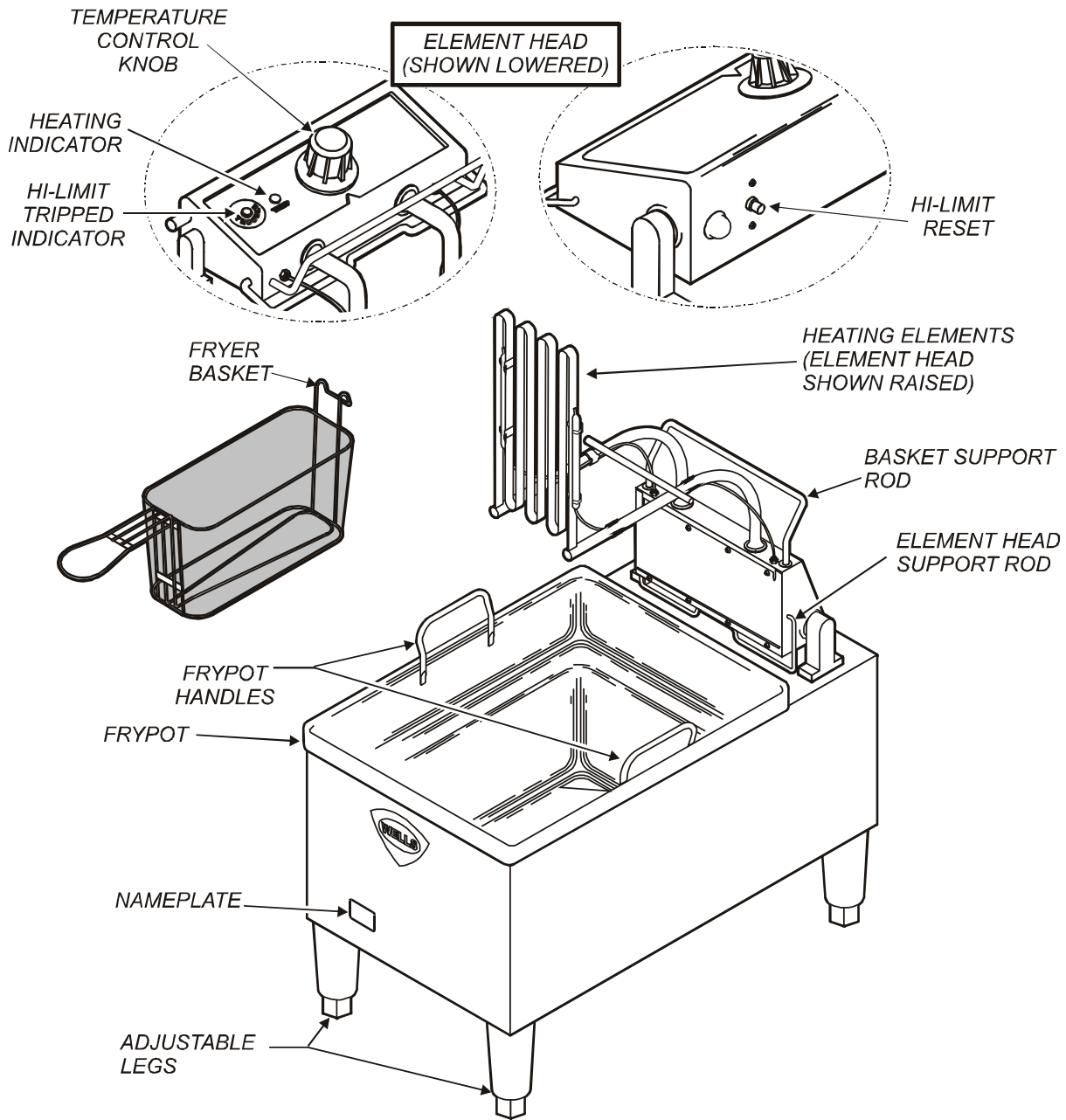

Fig. 1 Countertop Fryer Features & Operating Controls
F55 Shown - Others are Similar

PRECAUTIONS AND GENERAL INFORMATION



DANGER: SEVERE BURN HAZARD

Contact with hot oil will cause severe burns. Always wear protective clothing and heat resistant gloves when operating the fryer or filtering the oil.



WARNING: ELECTRIC SHOCK HAZARD

All servicing requiring access to non-insulated components must be performed by qualified service personnel. DO NOT open any access panel that requires the use of tools. Failure to heed this warning may result in severe electric shock.



WARNING: BURN HAZARD

DO NOT allow water or ice to contact hot oil. DO NOT attempt to cool the oil with water or ice. The water will boil violently, causing hot oil to foam and splatter. Contact with splattering or foaming hot oil will cause severe burns.

This appliance is intended for use in commercial establishments only.

This appliance is intended to prepare food for human consumption. No other use is recommended or authorized by the manufacturer or its agents.

Operators of this appliance must be familiar with the appliance use, limitations and associated restrictions. Operating instructions must be read and understood by all persons using or installing this appliance.

Cleanliness of this appliance is essential to good sanitation. Read and follow all included cleaning instructions and schedules to ensure the safety of the food product.

Disconnect this appliance from electrical power before performing any maintenance or servicing.

DO NOT submerge this appliance in water. This appliance is not jet stream approved. Do not direct water jet or steam jet at this appliance, or at any control panel or wiring. Do not splash or pour water on, in or over any controls, control panel or wiring.

Exposed surfaces of this appliance can be hot to the touch and may cause burns.

The technical content of this manual, including any wiring diagrams, schematics, parts breakdown illustrations and/or adjustment procedures, is intended for use by qualified technical personnel.

Any procedure which requires the use of tools must be performed by a qualified technician.

This manual is considered to be a permanent part of the appliance. This manual and all supplied instructions, diagrams, schematics, parts breakdown illustrations, notices and labels must remain with the appliance if it is sold or moved to another location.

This appliance is made in the USA. Unless otherwise noted, this appliance has American sizes on all hardware.



CAUTION: BURN HAZARD

Contact with hot oil may cause burns. DO NOT fill fryer beyond MAX OIL line on frypot.

For disposal of oil use only a container specifically designed for the disposal of hot oil. DO NOT fill hot oil disposal container beyond MAX OIL line.



CAUTION: RISK OF DAMAGE

DO NOT connect or energize this appliance until all installation instructions are read and followed. Damage to the appliance will result if these instructions are not followed.



CAUTION: HOT SURFACE

Exposed surfaces can be hot to the touch and may cause burns.

AGENCY LISTING INFORMATION

This appliance conforms to NSF Standard 4 for sanitation only if installed in accordance with the supplied *Installation Instructions* and maintained according to the instructions in this manual.

This appliance is  Listed under UL File E6070 for 120V, 208V and 240V.



INSTALLATION

UNPACKING & INSPECTION

Carefully remove the appliance from the carton. Remove all protective plastic film, packing materials and accessories from the Appliance before connecting electrical power or otherwise performing any installation procedure.

Carefully read all instructions in this manual and the *Installation Instruction Sheet* packed with the appliance before starting any installation.

Read and understand all labels and diagrams attached to the appliance.

Carefully account for all components and accessories before discarding packing materials. Store all accessories in a convenient place for later use.

COMPONENTS

- 1 or 2 ea. FRYPOT
- 2 or 4 ea. FRY BASKETS
- 4 ea. ADJUSTABLE LEGS (except F14)
- 4 ea. RUBBER FEET (F14 only)

SETUP

Setup the appliance only on a firm, level, non-combustible surface. Verify local codes for requirements. Concrete, tile, terrazzo or metal surfaces are recommended. Metal over combustible material may not meet code for non-combustible surfaces.

Install one adjustable leg at each corner of the fryer by screwing the leg into the fitting on the bottom. With a spirit level, check that the appliance is level front-to-back and side-to-side. Verify that the unit sits firmly **ON ALL FOUR LEGS OR RUBBER FEET**.

The lower portions of the legs are adjustable by turning; adjust as required to level the appliance. All four legs or rubber feet must be adjusted to firmly contact the counter in order to prevent tipping.

Refer to the *Installation Instruction Sheet* for required clearances. Maintain required clearances between the appliance and adjacent combustible surfaces.

Avoid storing flammable or combustible materials in, on or near the appliance.

NOTE: DO NOT discard the carton or other packing materials until you have inspected the appliance for hidden damage and tested it for proper operation. Refer to *SHIPPING DAMAGE CLAIM PROCEDURE* on the inside front cover of this manual.

IMPORTANT:

This installation must comply with all applicable Federal, Local and NFPA codes.

SCREW INTO CABINET
MOUNTING HOLES



TURN TO
ADJUST HEIGHT

Fig. 2 Adjustable Legs



WARNING: ELECTRIC SHOCK HAZARD

All servicing requiring access to non-insulated electrical components must be performed by a factory authorized technician.
DO NOT open any access panel which requires the use of tools. Failure to follow this warning can result in severe electrical shock.

F14 and F49 FRYER ELECTRICAL INSTALLATION

This fryer is equipped with a cord and plug, and requires a properly installed matching receptacle. Contact a licensed electrician to install an appropriate electric circuit and grounded receptacle.

Fig. 3 Fryer Power Plug and Receptacle Configuration

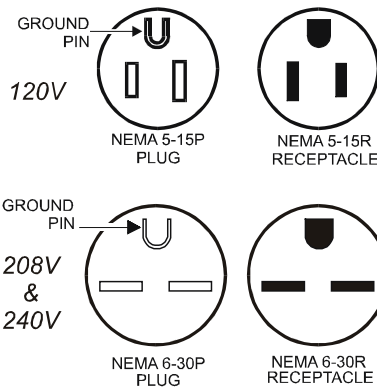

Be sure the TEMPERATURE CONTROL KNOB is turned to the OFF position, then plug the POWER CORD into the proper receptacle.

F55, F67 and F85 FRYER ELECTRICAL INSTALLATION

These fryers must be connected directly to the electric circuit. Conduit and strain relief must be provided by the electrician. Refer to fryer nameplate for circuit voltage and amperage requirements.

Raise the element head, remove the frypot and the cover at the rear of the fryer to gain access to the terminal block. The electrical inlet is provided by a knock-out in the rear panel.

If an equipment shutdown interface is required by local fire code, the flame sensor terminal block may be accessed by removing the back panel. Replace the jumper of the terminal block with wiring to a normally closed contact of the building fire management system. DO NOT connect power to the flame sensor terminal block. Wiring and contacts must be capable of handling 20 amps.

F67 and F85 fryers are shipped from the factory wired for three phase. Refer to included wiring diagram for conversion to single phase operation.



CAUTION: RISK OF DAMAGE

DO NOT connect or energize this appliance until all installation instructions are read and followed. Damage to the appliance will result if these instructions are not followed.



CAUTION: ELECTRIC SHOCK HAZARD

The ground pin of the power cord plug is part of a system designed to protect you from electric shock in the event of equipment damage. DO NOT cut the ground pin from the power cord plug in order to fit an existing receptacle; DO NOT twist a blade of the power cord plug in order to fit an existing receptacle.

Contact a licensed electrician to install an appropriate electrical circuit and receptacle.



CAUTION: ELECTRIC SHOCK HAZARD

The ground lug of F55, F67 and F85 fryers must be connected to a suitable building electric ground.

IMPORTANT:

Damage due to being connected to the wrong voltage or phase is NOT covered by warranty.

OPERATION

DANGER

DANGER: BURN HAZARD

Contact with hot oil will cause severe burns.

Always wear protective clothing and heat resistant gloves when operating the fryer.



CAUTION: HOT SURFACE

Exposed surfaces can be hot to the touch and may cause burns.

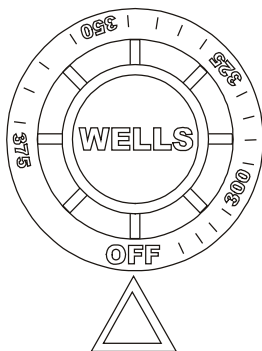

Fig. 3 Temperature Control Knob (F67)

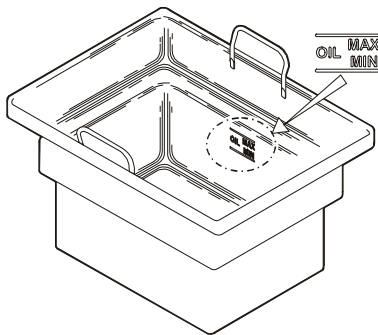

Fig. 4 Oil Level Marking

NOTE: If the oil temperature exceeds 440°F, the hi-limit safety will shut down the unit, and light the red **TROUBLE** light. To reset:

Allow the oil to cool, then press the red button on the back of the element head until it "clicks" and stays in. If tripping persists, see Troubleshooting Suggestions, page 9.

NORMAL OPERATION

- Be sure the TEMPERATURE CONTROL KNOB is turned to **OFF**.
 - Lower the ELEMENT HEAD into the frypot by pushing back on the BASKET SUPPORT ROD, raising the ELEMENT HEAD SUPPORT ROD, then carefully lowering the elements.
- Fill the FRYPOT with commercial-grade liquid shortening to the MIN OIL line.

Capacity:	F14	14 pounds
	F49, F55	15 pounds
	F67, F85	30 pounds (15 pounds per frypot)

IMPORTANT: DO NOT overfill the frypot. Cold oil will expand as it heats. Adding too much oil will allow the frypot to overflow during operation.

For best results, always use top grade commercial shortening made specially for frying. Maintain proper oil level in frypot during

operation.

- Turn the TEMPERATURE CONTROL KNOB to the desired temperature. The HEAT INDICATOR will glow. When the oil reaches the desired temperature, the heat indicator will go out. The heat indicator will go off and on during operation as the thermostat cycles to maintain temperature. For best results: DO NOT set temperature control to a temperature setting higher than is required for the food product.
- Load either or both baskets no more than 1/2 full with food product.
 - DO NOT overload fry baskets. For best results, load baskets uniformly to half full.
 - Using the basket handle, lower the baskets into the hot oil.
 - When food is cooked, lift the basket out of the oil by the handle. Hang the baskets on the BASKET SUPPORT ROD to drain.
- When the heat indicator light cycles off, the fryer is ready to cook the next load.
- Reduce temperature control to 225°F during idle periods to save power and extend the life of the oil. The fryer will return to operating temperature in just a few minutes when needed.
- Keep the fryer clean at all times. Rinse baskets frequently, and dry thoroughly, in order to prevent oil contamination.
- Drain the frypot completely after use. Filter the oil daily, or more often during heavy use.

CLEANING INSTRUCTIONS



DANGER: BURN HAZARD

Contact with hot oil will cause severe burns. Allow the fryer to cool before cleaning. Always wear protective clothing and heat resistant gloves when cleaning the fryer.

PREPARATION

Turn temperature control to *OFF*
Allow fryer to cool completely before cleaning
Unplug fryer from receptacle before cleaning

FREQUENCY

Daily, or as needed

TOOLS

Mild Detergent, Non-abrasive cleanser
Soft Cloth or Sponge, Plastic Scouring Pad
Container for disposal of used oil.



CAUTION: ELECTRIC SHOCK HAZARD

Disconnect fryer from electric power before cleaning.



CAUTION: BURN HAZARD

Allow fryer to cool completely before cleaning.



CAUTION: ELECTRIC SHOCK HAZARD

Do not submerge fryer in water.

CLEANING

1. Turn temperature control to OFF. Unplug the fryer.
2. Remove fry baskets, then swing the element head up and out of the frypot.
NOTE: The element support rod is spring-loaded. When the element head is raised, the support rod will automatically swing into position to keep the element head raised.
3. Allow the oil to cool to a safe temperature (120°F or less). Carefully remove the frypot: wearing heat-resistant gloves, lift the frypot by the handles. Drain the oil into a suitable container.
4. Frypot and baskets may be washed in a dishwasher, or with warm water and mild detergent. Rinse thoroughly and dry completely.
5. Wipe/brush all crumbs, breading and cooking debris from elements. Pay particular attention to the area between the element and the thermobulbs. Be careful that the capillary tubes of the thermobulbs are not moved or damaged during cleaning.
6. Keep all exterior surfaces free from splashed grease by wiping with a clean cloth dampened with warm water and mild detergent. A non-abrasive detergent and plastic scouring pad may be used for stubborn deposits.

IMPORTANT: DO NOT use steel wool or abrasive cleansers as these will damage the surface finish.

IMPORTANT: DO NOT submerge fryer in water. DO NOT spill or pour water into controls, control panel or wiring. Damage to internal components will occur.

7. Be certain frypot is completely dry, then reinstall in fryer.
 - a. Be sure the TEMPERATURE CONTROL KNOB is turned to *OFF*, then plug unit into receptacle.
 - b. Lower the ELEMENT HEAD into the frypot by pushing back on the ELEMENT LIFTING HANDLE, raising the SUPPORT ROD, then carefully lowering the elements.
 - c. Add new or filtered oil to the MIN OIL line in frypot

Procedure is complete.

IMPORTANT: DO NOT spill or pour water into controls, control panel or wiring.

DO NOT submerge fryer in water. Damage to internal components will occur. Damage to internal components from water damage is **not** covered by warranty.

IMPORTANT: DO NOT use steel wool or abrasive cleansers for cleaning the fryer cabinet or frypot.

To remove carbonization from frypot and element, see *PERIODIC CLEANING* on page 10.

IMPORTANT: Nickel plated frypot must be dried completely in order to prevent rusting, and to eliminate water contamination of the cooking oil.

DISPOSAL OF USED OIL



DANGER: BURN HAZARD

Contact with hot oil will cause severe burns. Allow the fryer to cool before cleaning. Always wear protective clothing and heat resistant gloves when handling hot oil.

PREPARATION	Turn temperature control to <i>OFF</i> Allow fryer to cool completely before draining
FREQUENCY	Daily, or as needed
TOOLS	Container for disposal of used oil.



CAUTION: BURN HAZARD

Allow fryer to cool completely before draining.

OIL DISPOSAL

1. Turn temperature control to OFF.
2. Allow the oil to cool to a safe temperature (120°F or 50°C).
3. Raise the element head and lift the frypot out of the fryer by the frypot handles.
4. Dispose of the used oil in an approved oil disposal receptacle, or filter the oil for reuse.
5. Wipe the frypot and reinstall in the fryer.

Procedure is complete.



CAUTION: SLIP AND FALL HAZARD

Clean up oil spills immediately. Slipping in oil can cause injury.



CAUTION: HEALTH HAZARD

Clean up oil spills immediately. Oil provides an environment for the growth of bacteria, which presents a health hazard.

TROUBLESHOOTING SUGGESTIONS

DESCRIPTION	POSSIBLE PROBLEM	SUGGESTED REMEDY
Fryer will not heat	Not plugged in or circuit breaker tripped	Plug into proper receptacle Reset circuit breaker
	Temperature control knob not set to desired temperature	Set to desired temperature
	Hi-limit safety tripped	Clean element ¹ , reset hi-limit
	Damaged internal component	Contact Wells Authorized Service Agency for repairs
Fryer will not maintain temperature	Temperature control thermostat thermobulb contaminated with cooking debris	Clean element ²
	Damaged internal component	Contact Wells Authorized Service Agency for repairs
Fryer leaks oil	Damaged frypot	Contact Wells Authorized Service Agency for repairs
Element head will not raise, will not stay in the up position, or will not lower	Frypot out of position, or has excess cooking debris in bottom	Check frypot for position Clean frypot
	Damaged hinge bracket or support rod	Contact Wells Authorized Service Agency for repairs

- ¹ The hi-limit safety is designed to shut down the fryer if the oil temperature exceeds 440°F. A build-up of cooking debris between the heating element and the thermobulb of the hi-limit safety will cause the hi-limit to trip prematurely. Clean the element so that oil may circulate freely between the element and the thermobulb. Reset the safety by pressing the red button on the basket of the element head.
- ² A build-up of cooking debris between the heating element and the thermobulb temperature control thermostat will cause inconsistent temperatures. Clean the element so that oil may circulate freely between the element and the thermobulb.

MAINTENANCE

Periodic cleaning is necessary to remove carbonization from the elements and frypot.

Frypot may be cleaned by the method described at right, or with a commercial frypot cleaner. Be sure to follow the manufacturer's directions.

Before cleaning, ALWAYS:

- Unplug the fryer and allow to cool.
- Drain the oil and wipe out the frypot.

PERIODIC CLEANING

Add 1/2 cup of granulated dishwasher detergent to frypot. Fill with water to the MAX OIL line.

Lower the element into the frypot and set the control knob to 225°F

Boil the mixture for five minutes. Turn the control knob to OFF. Allow the mixture to set in the frypot overnight.

After the soak period, raise the elements and remove any remaining carbonization with a stiff bristle brush. Be careful that the capillary tubes of the thermobulbs are not moved or damaged during cleaning.

Drain the frypot and wash with warm water and mild detergent.

Reinstall the frypot in the fryer. Add 1 quart of vinegar, then fill to the MAX OIL line with cold water.

Lower the elements into the vinegar solution. Allow to set for 15 minutes.

Drain the frypot and rinse with clean water. Dry the frypot and elements thoroughly before returning the fryer to operation.

IMPORTANT: Nickel plated frypot must be dried completely in order to prevent rusting, and to eliminate water contamination of the cooking oil.

EXPLODED VIEW: F14

F14 COUNTERTOP 14# FRYER

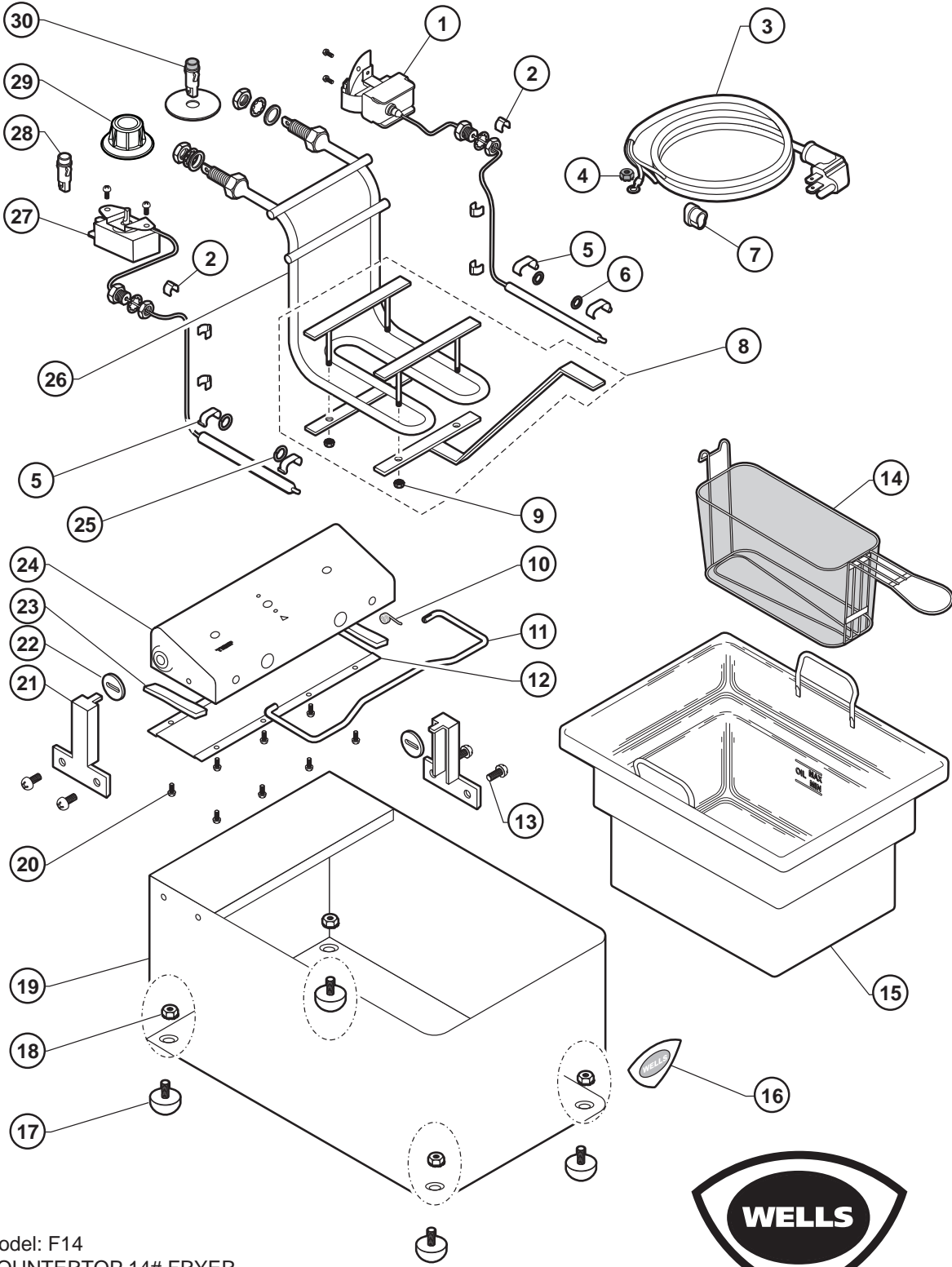

Model: F14
COUNTERTOP 14# FRYER

PL301



IL1864 Rev. A 8/17/09

301 p/n 2M-307588 Owners Manual Countertop Standard Electric Fryers

F14 COUNTERTOP 14# FRYER (LLF-14)		
Fig No.	Part Number	Description
1	WS-58656	HI-LIMIT MAN RESET 440°F
2	2C-38667	CLAMP CAPILLARY FLOOR FRY
3	2E-45061	CORD SET 120V 15A 14G 5-15P
	2E-35259	CORD NEMA 6-30P
4	2C-35736	NUT 8-32 HEX KEPS MS GREEN
5	2C-45777	CLAMP BULB LLF-14
6	2B-35637	RING WIRE SS .25ID
7	2K-45788	STRAIN RELIEF SR7W-2-LLF
8	DD-65783	HANDLE ELEM LIFT ASSY LLF
	DD-65784	CLAMP KIT ELEM REAR
9	2C-35455	NUT 8-32 HEX MS SS
10	2P-32428	SPRING SUPPORT ROD
11	WS-52427	ROD SUPPORT SHORT HEAD
12	E7-35028	COVER CONTROL BOX WO/SAF
13	DD-35890	PROTECTOR SW INF STAND UN
14	2B-45731	FRY BASKET LLF14
15	5E-20169	POT F49 55 67 85 15LB CAP
16	2M-300534	TRADEMARK DOMED LABEL WAR
17	2A-45728	FOOT RUBBER LLW LLF
18	2C-31053	NUT 8-32 KEPS MS NICKEL
19	WS-65765	SHELL ASSY LLF-14
20	2C-35566	SCREW 6-32X1/4 PH TR HD M
21	E7-45767	BRKT HEAD PIVOT LLF-14
22	E7-33436	WASHER SLOTTED PIVOT BRKT
23	2I-35747	GASKET DRWR RWS CLOSED CE
24	E7-45774	BOX CONTROL ASSY LLF-14
25	2B-30792	RING WIRE SS .37ID
26	2N-45725UL	ELEM 120V FRYER LLF14
	2N-45729UL	ELEM 240V FRYER LLF14
27	2T-30133	THERMO CTRL
28	2J-30516	LIGHT SIGNAL AMBER M3938P
29	2R-34066	KNOB CONTROL ASSY F-1905
30	2J-31157	LIGHT SIGNAL RED
NI	2E-307333	RELAY 120VAC 30A
	2E-307334	RELAY 240VAC

EXPLODED VIEW: F49

F49 COUNTERTOP SINGLE-HEAD FRYER

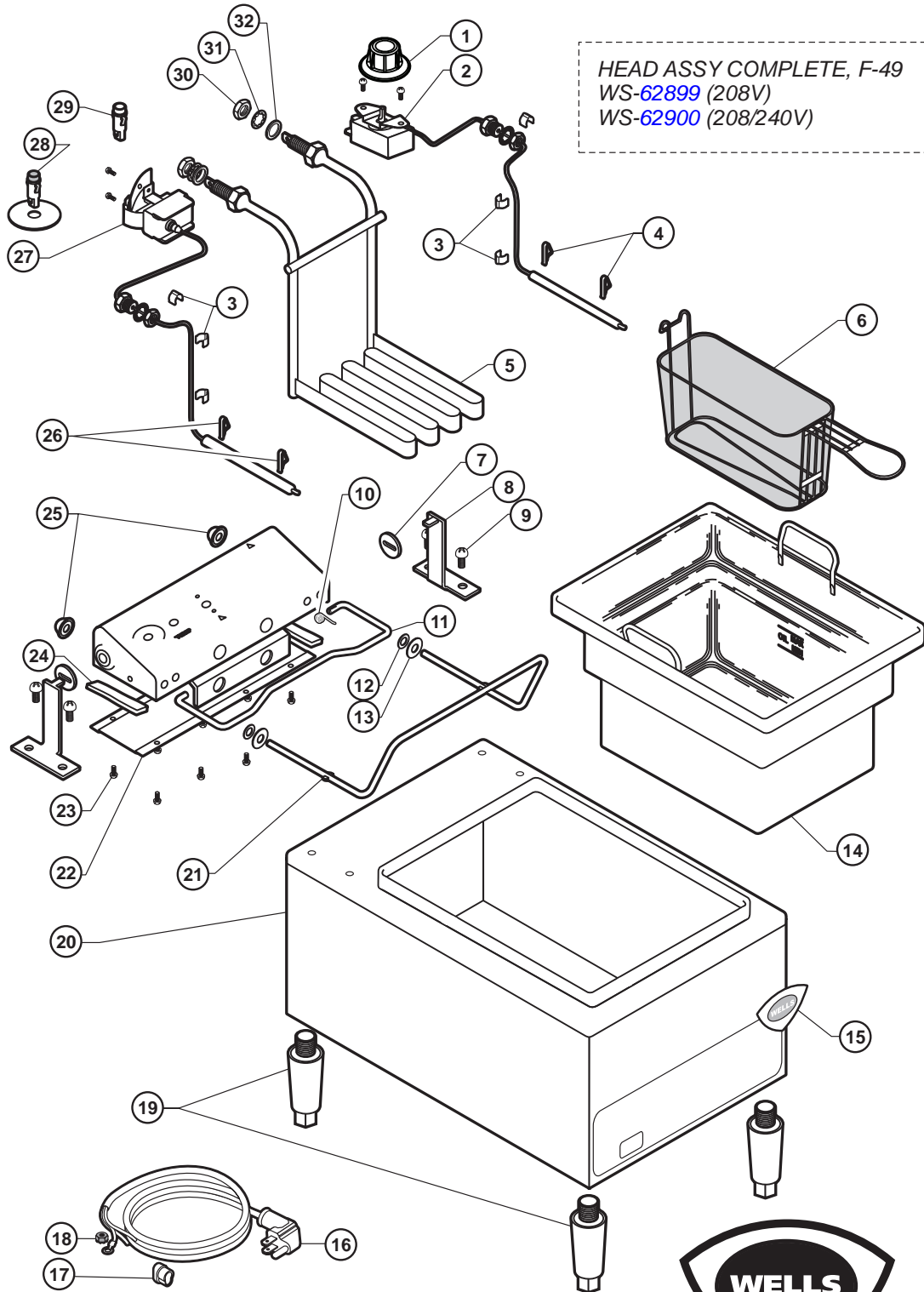

Model: F49
COUNTERTOP SINGLE HEAD FRYER

PL301

IL1865 Rev. A 8/17/09



F49 COUNTERTOP SINGLE-HEAD FRYER		
Fig No.	Part Number	Description
1	2R-34066	KNOB CONTROL ASSY
2	2T-30133	THERMO CTRL
3	2C-30157	CLIP CAPILLARY
4	2C-43665	CLAMP THERMO BULB F49
5	2N-42891UL	ELEM 208V 4600W
	2N-42892UL	ELEM 240V 4600W
6	5E-20161	BSKT 1/2SIZE F49
	5E-20162	BASKET FULL SIZE
7	E7-33436	WASHER SLOTTED PIVOT BRKT
8	E7-33435	BRKT PIVOT F49
9	2C-33890	SCREW 12-24X3/4PH PAN ROL
10	2P-32428	SPRING SUPPORT ROD
11	2A-32427	ROD SUPPORT SHORT HEAD
12	2C-31208	WASHER NEOPRENE BASKET
13	2C-31207	WASHER FLAT SS BASKET ROD
14	2D-301344	POT ASSY - F SERIES FRYER
15	2M-300534	TRADEMARK DOMED LABEL
16	2E-35259	CORD SET 250V 30A 12G 6-30P
17	2K-45788	STRAIN RELIEF SR7W-2 LLF
18	2C-35736	NUT 8-32 HEX KEPS MS GREEN
19	2R-Y5092	FEET ADJ 4GRAY 3/8-16 PK, PLASTIC
	2A-Z0314	FEET ADJ METAL 4IN
20	DD-34206	SHELL ASSY F49
21	WS-51206	BASKET ROD
22	E7-34323	COVER CONTROL BOX F49
23	2C-35566	SCREW 6-32X1/4 PH TR HD
24	2I-35747	GASKET DRWR RWS CLOSED CE
25	2P-34452	CAP PUSH ON TYPE BASKET
26	2C-49689	CLAMP BULB SS F49RT
27	WS-58656	HI-LIMIT MAN RESET 440°F
28	2J-31157	LIGHT SIGNAL RED
29	2J-30516	LIGHT SIGNAL AMBER
30	2C-30172	NUT 7/8-14 HEX
31	2C-30176	WASHER LOCK FTG TUBE FRAM
32	2I-Z12311	GASKET-FIBER WASHER
NI	WS-62899	HEAD ASSY F49 208V
NI	WS-62900	HEAD ASSY F49 208/240
NI	2E-307334	RELAY 240V

EXPLODED VIEW: F55

F55 COUNTERTOP SINGLE-HEAD FRYER

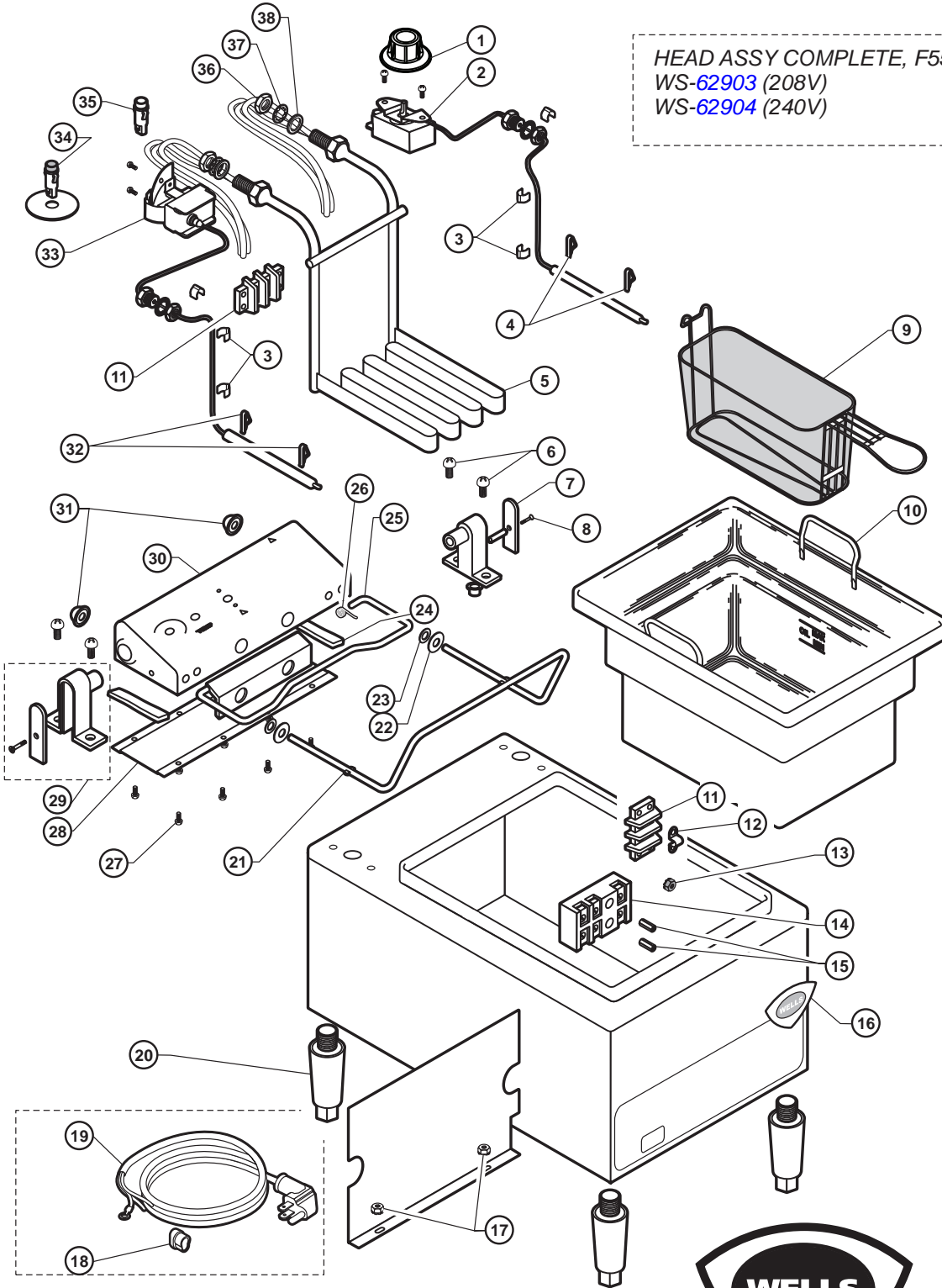

HEAD ASSY COMPLETE, F55
WS-62903 (208V)
WS-62904 (240V)

Model: F55
COUNTERTOP SINGLE HEAD FRYER

PL301



IL1865 Rev. A 8/17/09

301 p/n 2M-307588 Owners Manual Counter Top Standard Electric Fryers

F55 COUNTERTOP SINGLE-HEAD FRYER		
Fig No.	Part Number	Description
1	2R-35511	KNOB CONTROL ASSY SP-715
2	WS-55510	TEHRMO CTRL FRYER
3	2C-30157	CLIP CAPILLARY
4	2C-49689	CLAMP BULB SS
5	2N-42842UL	ELEM 208V 5750W
	2N-42866UL	ELEM 240V 5750W
6	2C-33890	SCREW 12-24X3/4PH PAN ROL
7	2A-32806	COVER PIVOT BRKT TUMBLED
8	2C-31717	SCREW 8-32X7/8 PH FL ROLO
9	2B-43688	BASKET WIRE TWIN
9	2B-43689	BASKET WIRE F55 SINGLE
10	2D-301344	POT ASSY - F SERIES FRYER
11	2E-33068	TERM BLOCK FLAME SENSOR
12	2E-34005	JUMPER FLAME SENSOR TERM
13	2C-35736	NUT 8-32 HEX KEPS MS GREEN
14	WS-50131	TERM BLK KIT-3 POLE .85AMP
15	2C-41974	NUT 8-32 HEX 7/8 LONG ALU
16	2M-300534	TRADEMARK DOMED LABEL
17	2C-31053	NUT 8-32 KEPS MS NICKEL
18	2K-45788	STRAIN RELIEF
19	DD-74897	CORD ASSY 6-50 3W 250V
20	2R-Y5092	FEET ADJ 4" GRAY 3/8-16, PLASTIC
	2A-Z0314	FEET ADJ METAL 4"
21	WS-51206	BASKET ROD
22	2C-31207	WASHER FLAT SS BAXKET ROD
23	2C-31208	WASHER NEOPRENE BASKET ROD
24	2I-35747	GASKET DRWR RWS CLOSED CE
25	WS-52427	ROD SUPPORT SHORT HEAD
26	2P-32428	SPRING SUPPORT ROD
27	2C-35566	SCREW 6-32X1/4 PH TR HD
28	E7-35028	COVER CONTROL BOX WO/SAF
29	WS-50183	HINGE BRACKET END
30	DD-304644	SWITCH LIQUID LEVEL HDWN
31	2P-34452	CAP PUSH ON TYPE BASKET
32	2C-49689	CLAMP BULB SS
33	WS-58656	HI-LIMIT MAN RESET 440F
34	2J-31157	LIGHT SIGNAL RED
35	2J-30516	LIGHT SIGNAL AMBER
36	2C-30172	NUT 7/8-14 HEX
37	2C-30176	WASHER LOCK FTG TUBE FRAM
38	2I-Z12311	GASKET -FIBER WASHER
NI	WS-62903	HEAD ASSY F55 208V
NI	WS-62904	HEAD ASSY F55 240V
NI	2E-307334	RELAY 240VAC

F67 COUNTERTOP DUAL-HEAD FRYER - CABINET COMPONENTS

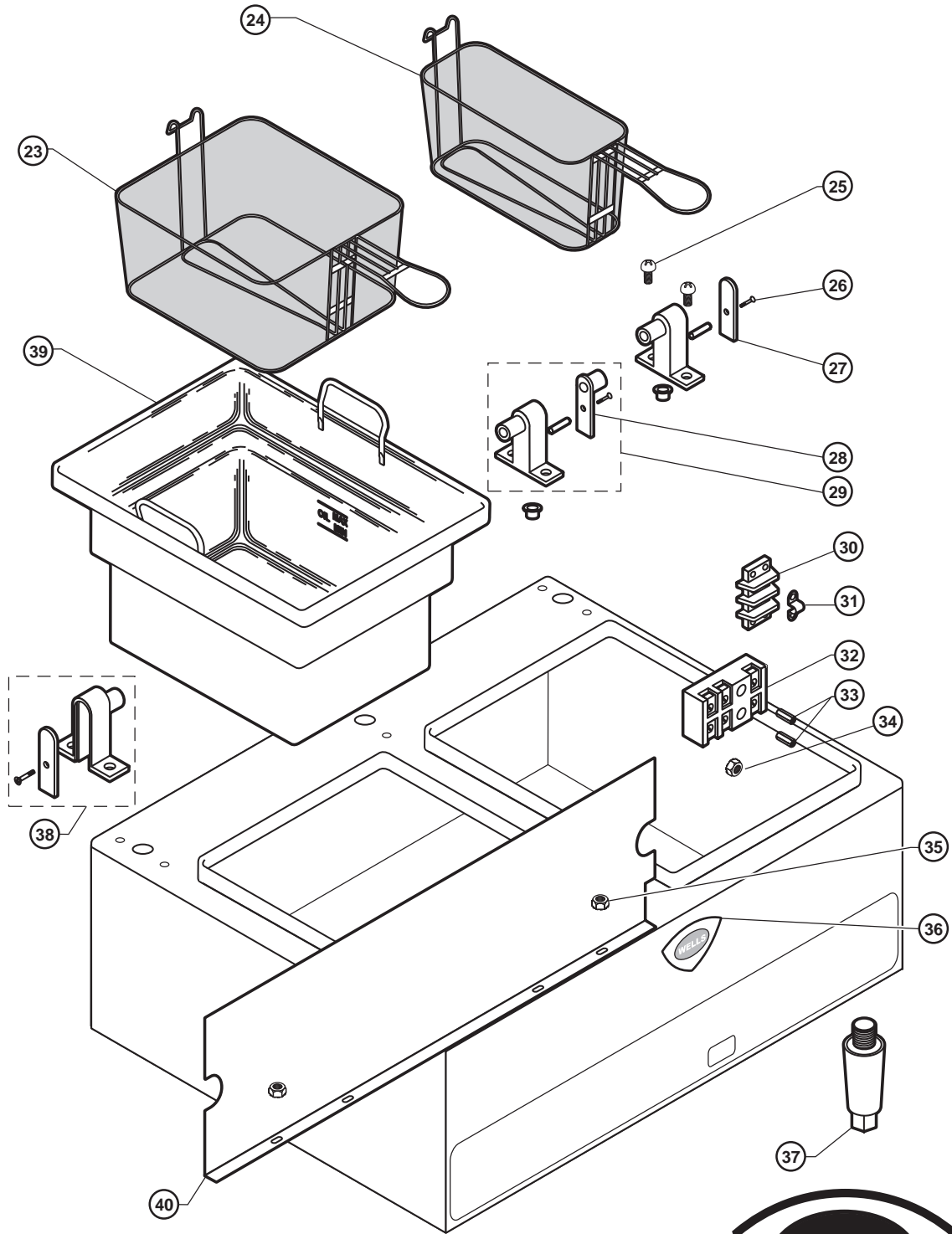

301 p/n 2M-307588 Owners Manual Counter Top Standard Electric Fryers

Model: F67
COUNTERTOP DUAL-HEAD FRYER - CABINET COMPONENTS

PL301



IL1868 Rev. B 5/27/10

PARTS LIST: F67

Refer to exploded views on pages 14 & 15.

F67 COUNTERTOP DUAL-HEAD FRYER		
Fig No.	Part Number	Description
1	WS-62915	HEAD ASSY F67 208V
	WS-62916	HEAD ASSY F67 208-240V
2	2R-34066	KNOB CONTROL ASSY
3	2T-30133	THERMO CTRL
4	2C-30157	CLIP CAPILLARY
5	2C-43665	CLAMP THERMO BULB
6	2N-42891UL	ELEM 208V 4600W
	2N-42892UL	ELEM 240V 4600W
7	2P-32428	SPRING SUPPORT ROD
8	WS-52427	ROD SUPPORT SHORT HEAD
9	2C-31208	WASHER NEOPRENE BASKET
10	2C-31207	WASHER FLAT SS BASKET
11	WS-51206	BASKET ROD
12	2C-35566	SCREW 6-32X1/4 PH TR HD
13	E7-34323	COVER CONTROL BOX
14	2I-35747	GASKET DRWR RWS CLOSED CE
15	2P-34452	CAP PUSH ON TYPE BASKET
16	2C-49689	CLAMP BULB SS
17	WS-58656	THERMO HI-LIMIT MAN RESET
18	2J-31157	LIGHT SIGNAL RED
19	2J-30516	LIGHT SIGNAL AMBER
20	2C-30172	NUT 7/8-14 HEX
21	2C-30176	WASHER LOCK FTG TUBE FRAM
22	2I-Z12311	GASKET -FIBER WASHER
23	2B-43689	BASKET WIRE SINGLE
24	2B-43688	BASKET WIRE TWIN
25	2C-33890	SCREW 12-24X3/4PH PAN ROL
26	2C-31717	SCREW 8-32X7/8 PH FL ROLO
27	2A-32806	COVER PIVOT BRKT TUMBLED
28	H6-33245	COVER PIVOT DBL TUMBLE DE
29	WS-53895	CENTER PIBOT BRKT
30	2E-33068	TERM BLOCK FLAME SENSOR
31	2E-34005	JUMPER FLAME SENSOR
32	WS-50131	TERM BLOCK KIT
33	2C-41974	NUT 8-32 HEX 7/8 LONG ALU
34	2C-35736	NUT 8-32 HEX KEPS MS GREEN
35	2C-31053	NUT 8-32 KEPS MS NICKEL
36	2M-300534	TRADEMARK DOMED LABEL
37	2R-Y5092	FEET ADJ 4 GRAY 3/8-16, PLASTIC
	2A-Z0314	FEET ADJ METAL 4"
38	WS-50183	HINGE BRACKET END
39	2D-301344	POT ASSY - F SERIES FRYER
40	E7-507335	COVER CONTROL BOX
NI	2E-307334	RELAY 240V

F85 - COUNTERTOP DUAL-HEAD FRYER - FRY HEAD COMPONENTS

NOTE: Unit has two identical fryer heads. Only one is shown

① HEAD ASSY COMPLETE, F-85
 62903 (208V)
 62904 (240V)

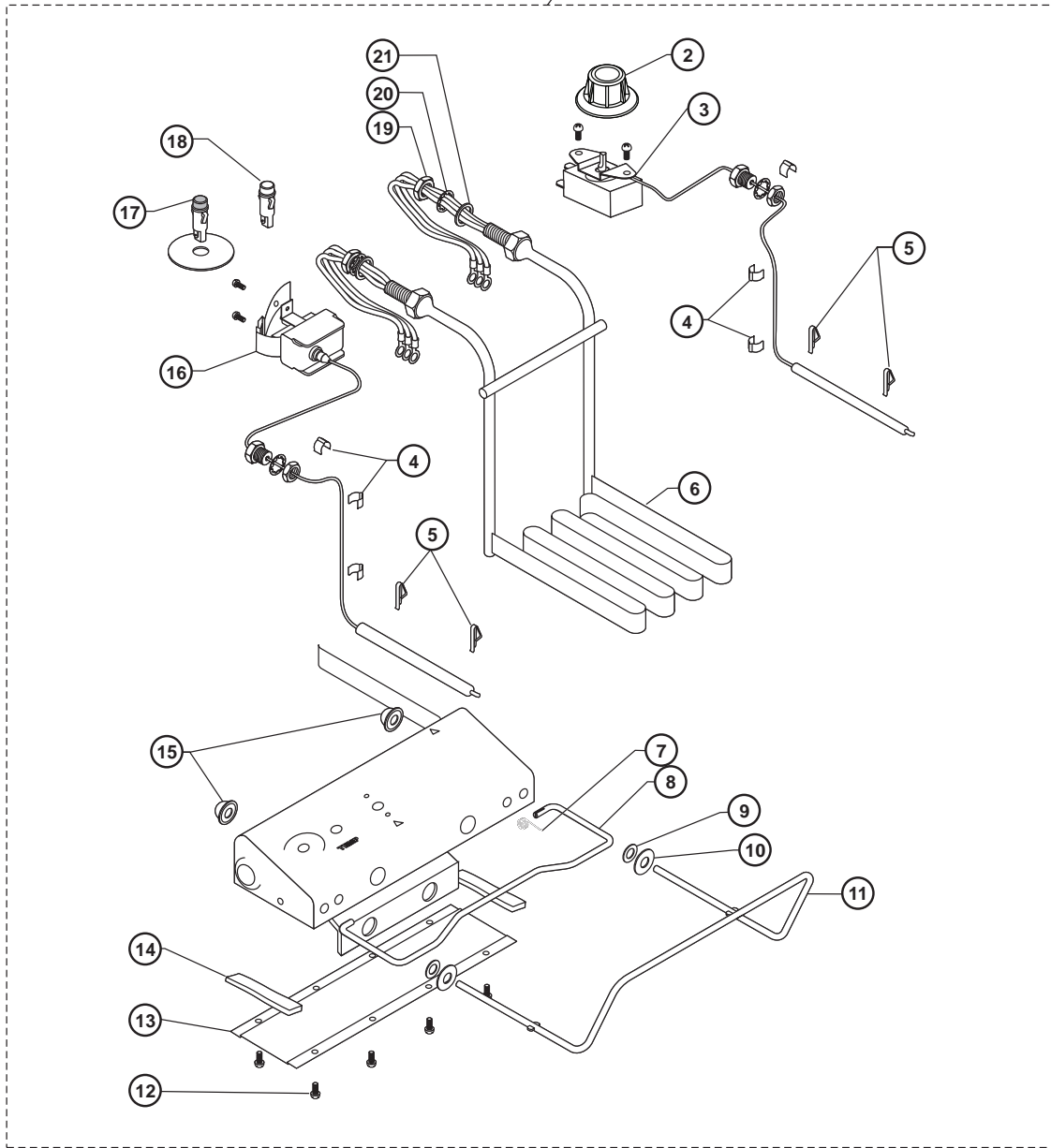

301 p/n 2M-307588 Owners Manual Counter Top Standard Electric Fryers

Model: F85
 COUNTERTOP DUAL-HEAD FRYER, FRY HEAD COMPONENTS

PL301



IL1869 Rev. A 8/18/09

EXPLODED VIEW: F85

F85 - COUNTERTOP DUAL-HEAD FRYER - CABINET COMPONENTS

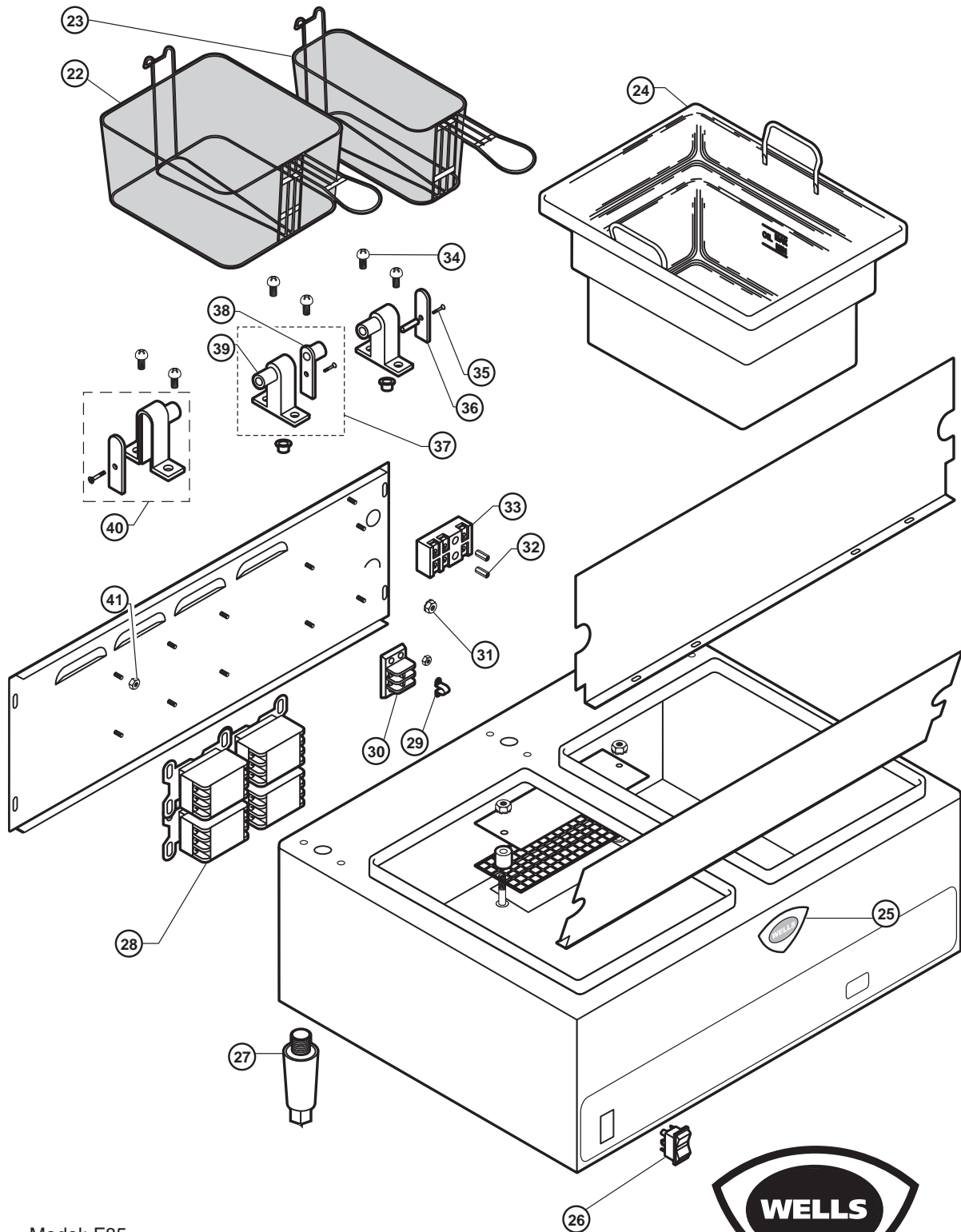

Model: F85
COUNTERTOP DUAL-HEAD FRYER,
CABINET COMPONENTS
PL301



IL1870 Rev. A 8/18/09

301 p/n 2M-307588 Owners Manual Counter Top Standard Electric Fryers

Refer to exploded views on pages 16 & 17.

F85 COUNTERTOP DUAL-HEAD FRYER		
Fig No.	Part Number	Description
1	WS-62903	HEAD ASSY 208V
	WS-62904	HEAD ASSY 240V
2	2R-35511	KNOB CONTROL ASSY
3	WS-55510	THERMO CTRL FRYER
4	2C-30157	CLIP CAPILLARY
5	2C-49689	CLAMP BULB SS
6	2N-42891UL	ELEM 208V 4600W
	2N-42892UL	ELEM 240V 4600W
	2N-42866UL	ELEM 400V 5750W
	2N-42317UL	ELEM 480V 575KW
7	2P-32428	SPRING SUPPORT ROD
8	WS-52427	ROD SUPPORT SHORT HEAD
9	2C-31208	WASHER NEOPRENE BASKET
10	2C-31207	WASHER FLAT SS BASKET ROD
11	WS-51206	BASKET ROD
12	2C-35566	SCREW 6-32X1/4 PH TR HD
13	E7-34323	COVER CONTROL BOX
14	2I-35747	GASKET DRWR RWS CLOSED CE
15	2P-34452	CAP PUSH ON TYPE BASKET
16	WS-58656	THERMO HI-LIMIT MAN RESET
	2T-38656	THERMO SAF MAN RESET, 480V
17	2J-31157	LIGHT SIGNAL RED
18	2J-30516	LIGHT SIGNAL AMBER
	M3-WL0113	ASSY, PILOT LIGHT AMBER, 480V

F85 COUNTERTOP DUAL-HEAD FRYER		
Fig No.	Part Number	Description
19	2C-30172	NUT 7/8-14 HEX
20	2C-30176	WASHER LOCK FTG TUBE FRAM
21	2I-Z12311	GASKET-FIBER WASHER
22	2B-43689	BASKET WIRE SINGLE
23	2B-43688	BASKET WIRE TWIN
24	2D-301344	POT ASSY - F SERIES FRYER
25	2M-300534	TRADEMARK DOMED LABEL
26	2E-35127	SWITCH ROCK PLAS BEZEL
27	2R-Y5092	FEET ADJ 4" GRAY 3/8-16
	2A-Z0314	FEET ADJ METAL 4"
28	2E-37779	CONTACTOR 3-POLE 208V 40A
	2E-37780	CONTACTOR 3P 240V, 40A ALT3
29	2E-34005	JUMPER FLAME SENSOR TERM
30	2E-33068	TERM BLOCK FLAME SENSOR
31	2C-35736	NUT 8-32 HEX KEPS MS GREEN
32	2C-41974	NUT 8-32 HEX 7/8 LONG ALU
33	WS-50131	TERM BLOCK KIT -3POLE
34	2C-33890	SCREW 12-24X3/4 PH PAN ROL
35	2C-31717	SCREW 8-32X7/8 PH FL ROLO
36	2A-32806	COVER PIVOT BRKT TUMBLED
37	WS-53895	CENTER POST BRKT
38	H6-33245	COVER PIVOT DBL TUMBLE
39	2A-30183	BRKT PIVOT CAST
40	WS-50183	HING BRACKET END
41	2C-31053	NUT 8-32 KEPS MS NICKEL
NI	2E-40873	TRANSORMER 480V TO 240V

EXPLODED VIEW: F1725

F1725 - COUNTERTOP MULTI-ELEMENT SINGLE-HEAD FRYER HEAD ASSEMBLY COMPONENTS

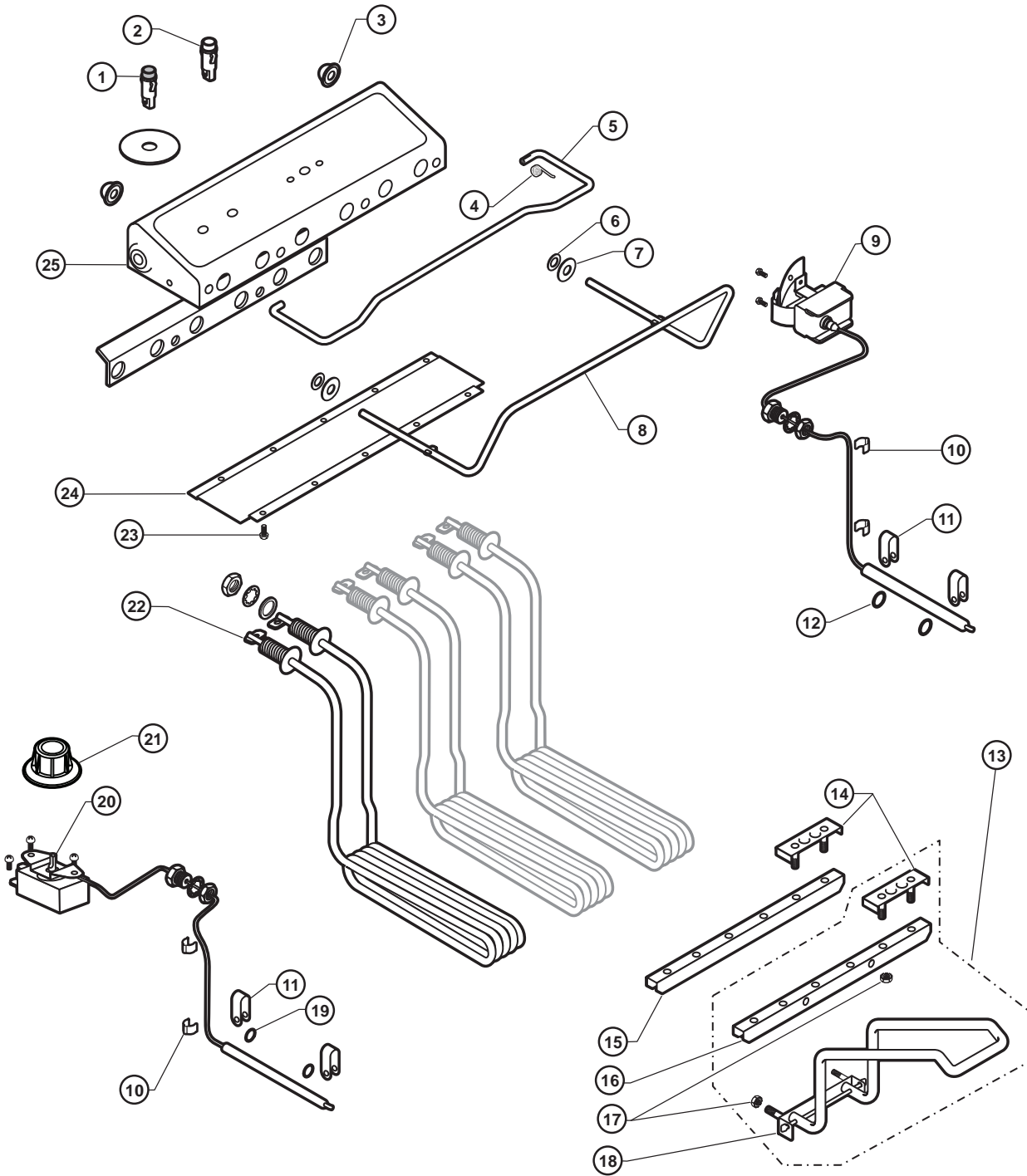

Model: F1725
COUNTERTOP MULTI-ELEMENT SINGLE-HEAD FRYER,
CABINET COMPONENTS
PL301



IL1871 Rev. A 8/19/09

F1725 - COUNTERTOP MULTI-ELEMENT SINGLE-HEAD FRYER CABINET COMPONENTS

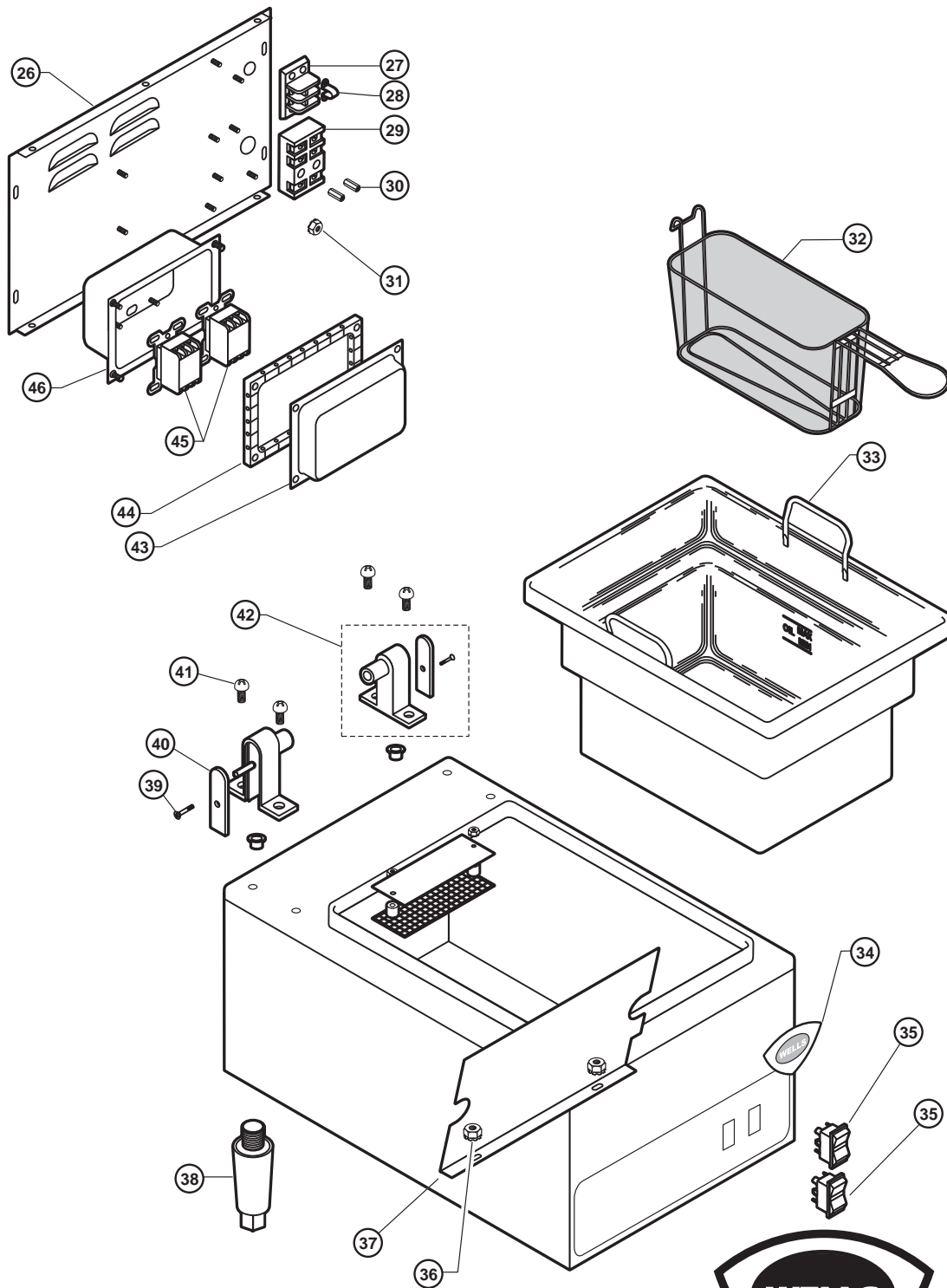

301 p/n 2M-307588 Owners Manual Counter Top Standard Electric Fryers

Model: F1725
COUNTERTOP MULTI-ELEMENT SINGLE-HEAD FRYER,
CABINET COMPONENTS
PL301



IL1872 Rev. A 3/14/11

PARTS LIST: F1725

Refer to exploded views on pages 16 & 17.

F1725 COUNTERTOP DUAL-HEAD FRYER		
Fig No.	Part Number	Description
1	2J-31157	LIGHT SIGNAL RED
2	2J-30516	LIGHT SIGNAL AMBER
3	2P-54452	CAP PUSH ON TYPE BASKET
4	2P-32428	SPRING SUPPORT ROD
5	2A-34665	ROD HEAD SUPPORT
6	2C-31208	WASHER NEOPRENE BASKET
7	2C-31207	WASHER FLAT SS BASKET
8	2A-34666	ROD BASKET
9	WS-58656	THERMO HI-LIMIT MAN RESET
10	2C-38667	CLAMP CAPILLARY FLOOR FRY
11	2A-38665	CLAMP BULB FLOOR FRYERS
12	2B-38751	RING WIRE .250X .093
13	WS-62568	KIT LIFT HANDLE F1725
14	E7-38718	BRKT ELEM 5.75KW
15	E7-38717	CHANNEL ELEM FLOOR FRYER
16	E7-38717	CHANNEL ELEM FLOOR FRYER
17	2C-31053	NUT 8-32 KEPS MS NICKEL
18	2A-38729	HANDLE ASSY LIFT FLOOR
19	2B-35637	RING WIRE SS .25 ID
20	WS-55510	THERMO CTRL FRYER
21	2R-35511	KNOB CONTROL ASSY
22	2N-38661UL	ELEM 208V 5750W
	2N-38662UL	ELEM 240V 5750W
23	2C-35566	SCREW 6-32X1/4 PH TR HD
24	E7-34662	COVER CONTROL BOX BOTTOM
25	DD-30147	SWITCH DISCONNECT
26	DD-62850	PANEL ASSY BK F1725 208V
27	2E-33068	TERM BLOCK FLAME SENSOR
28	2E-34005	JUMPER FLAME SENSOR TERM
29	WS-50131	TERM BLOCK KIT -3POLE
30	2C-41974	NUT 8-32 HEX 7/8 LONG ALU
31	2C-35736	NUT 8-32 HEX KEPS MS GREEN
32	2B-42705	BASKET TWIN WIRE F1725
33	E7-42347	POT W/O DRAIN F1725 W/STR
34	2M-300534	TRADEMARK DOMBED LABEL

F1725 COUNTERTOP DUAL-HEAD FRYER		
Fig No.	Part Number	Description
35	2E-35127	SWITCH ROCK PLAS BEZEL
	2E-35128	SWITCH ROCK PLAS BELEL
36	2C-31053	NUT 8-32 KEPS MS NICKEL
37	E7-37896	ACCESS COVER FR RR F2000
38	2R-Y5092	FEET ADJ 4" GRAY 3/8-16, PLASTIC
	2A-Z0314	FEET ADJ METAL 4"
39	2C-31717	SCREW 8-32X7/8 PH FL ROLO
40	2A-32806	COVER PIVOT BRKT TUMBLED
41	2C-33890	SCREW 12-24X3/4PH PAN ROL
42	WS-50183	HINGEBRACKET END
43	E7-Z12073	COVER CONTACTOR
44	2A-35725	GASKET MOLDED CONT BOX
45	2E-37779	CONTACTOR 3POLE 208V 40A
	2E-37780	CONTACTOR 3P 240V 40A
46	E7-Z12078	BOX - CONTACTOR

WIRING DIAGRAM

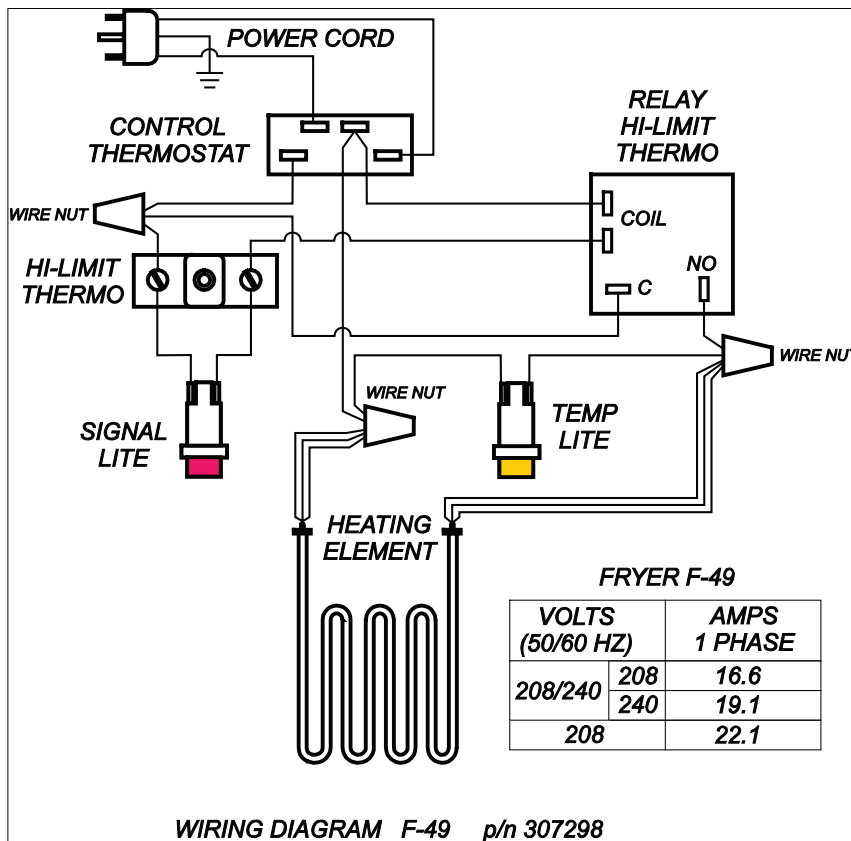
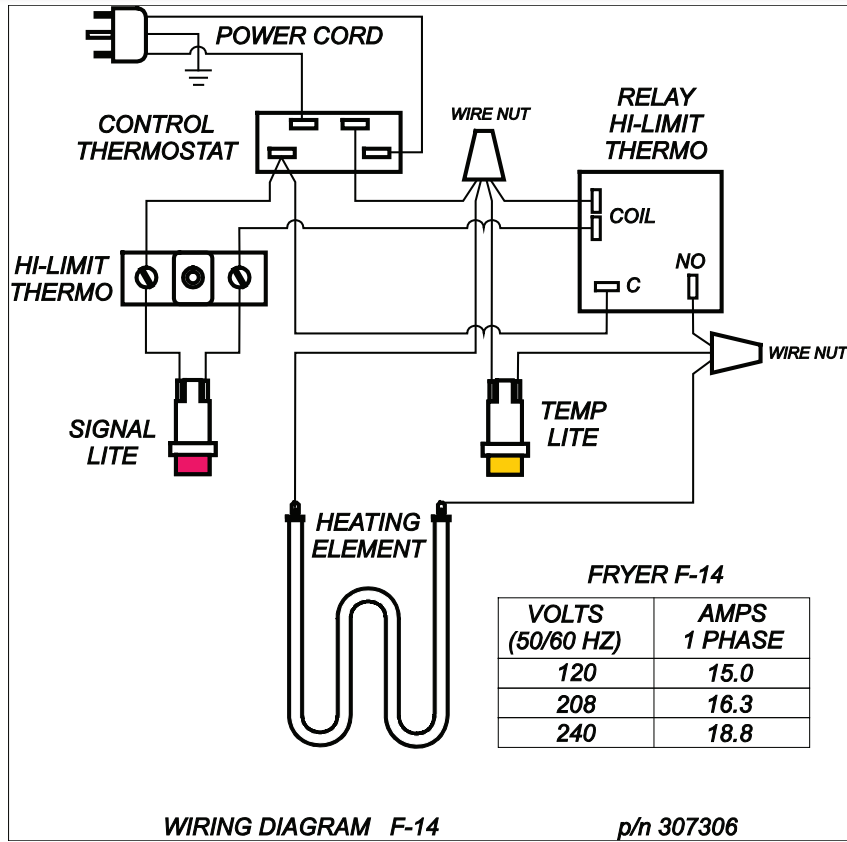

WIRING DIAGRAM

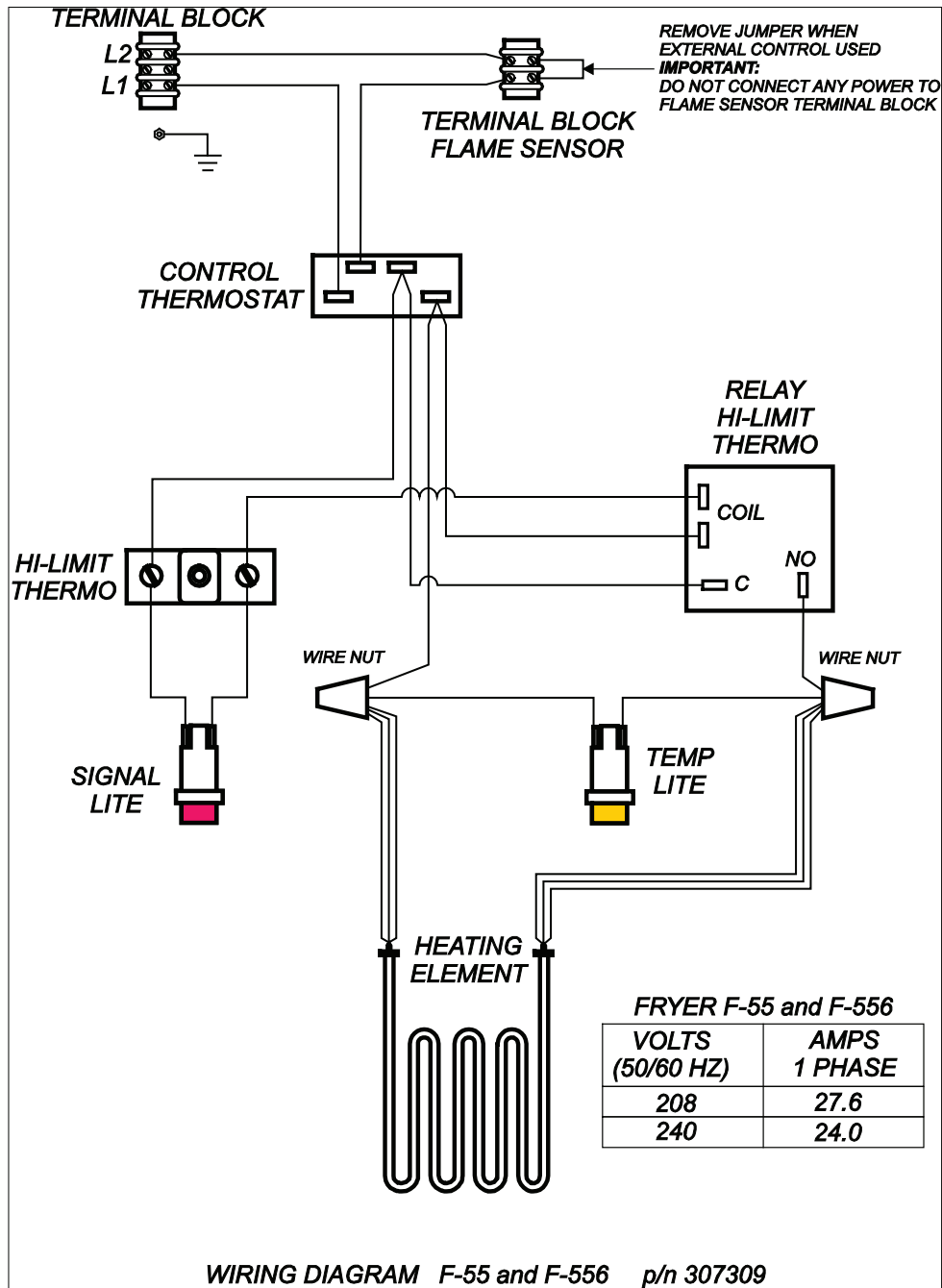

WIRING DIAGRAM

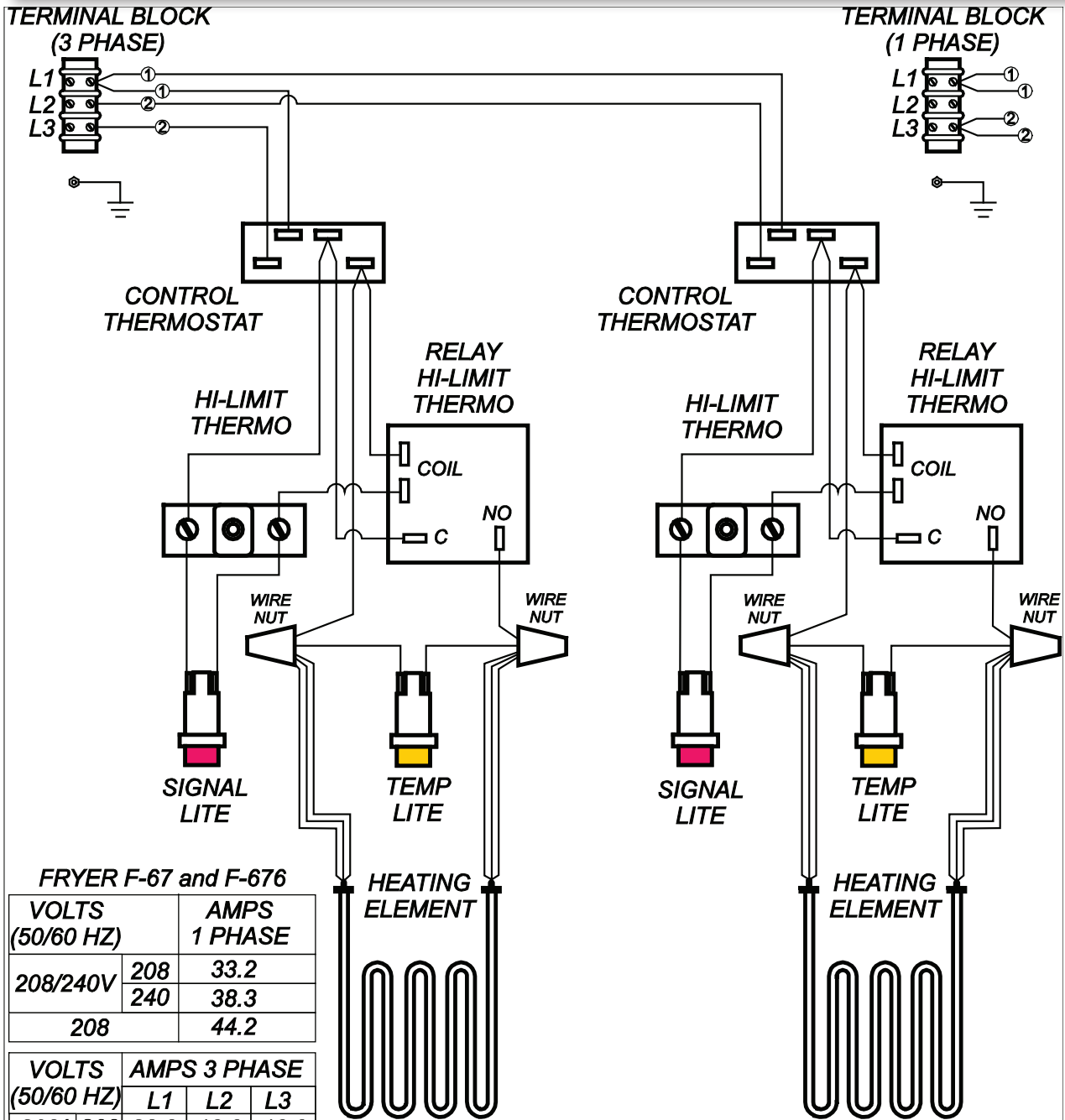

FRYER F-67 and F-676

VOLTS (50/60 HZ)		AMPS 1 PHASE		
208/240V	208	33.2		
	240	38.3		
208		44.2		

VOLTS (50/60 HZ)		AMPS 3 PHASE		
		L1	L2	L3
208/	208	28.8	16.6	16.6
240V	240	33.2	19.2	19.2
	208	38.3	22.1	22.1

WIRING DIAGRAM F-67 and F-676 p/n 307302

301 p/n 2M-307588 Owners Manual Counter Top Standard Electric Fryers

WIRING DIAGRAM

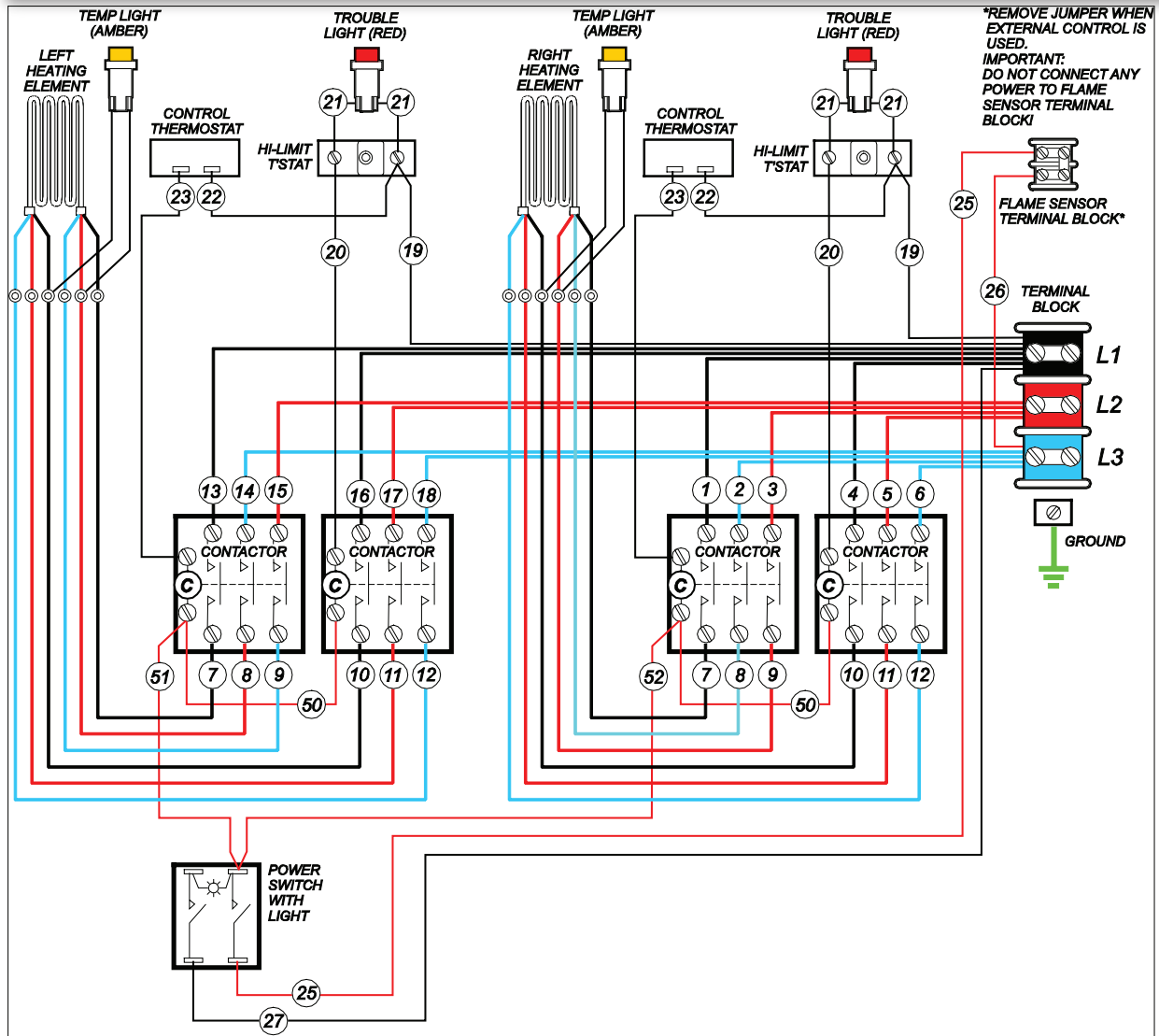

*REMOVE JUMPER WHEN EXTERNAL CONTROL IS USED.
 IMPORTANT: DO NOT CONNECT ANY POWER TO FLAME SENSOR SENSOR TERMINAL BLOCK!

VOLTS 50/60 HZ	3 PHASE AMPS PER LEG			1 PHASE AMPS
	L1	L2	L3	
208	31.9	31.9	31.9	—
240	27.6	27.6	27.6	47.9

WIRING DIAGRAM F-85 p/n 307495

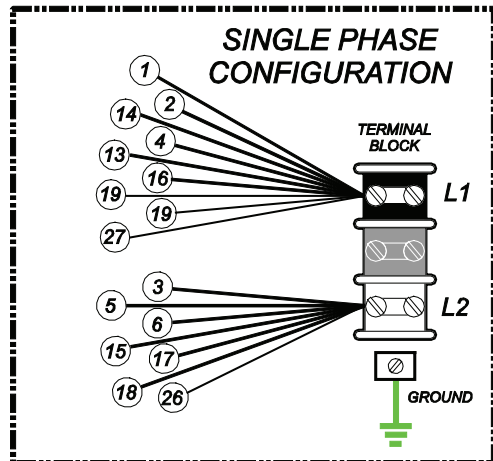

301 p/n 2M-307588 Owners Manual Counter Top Standard Electric Fryers

WIRING DIAGRAM

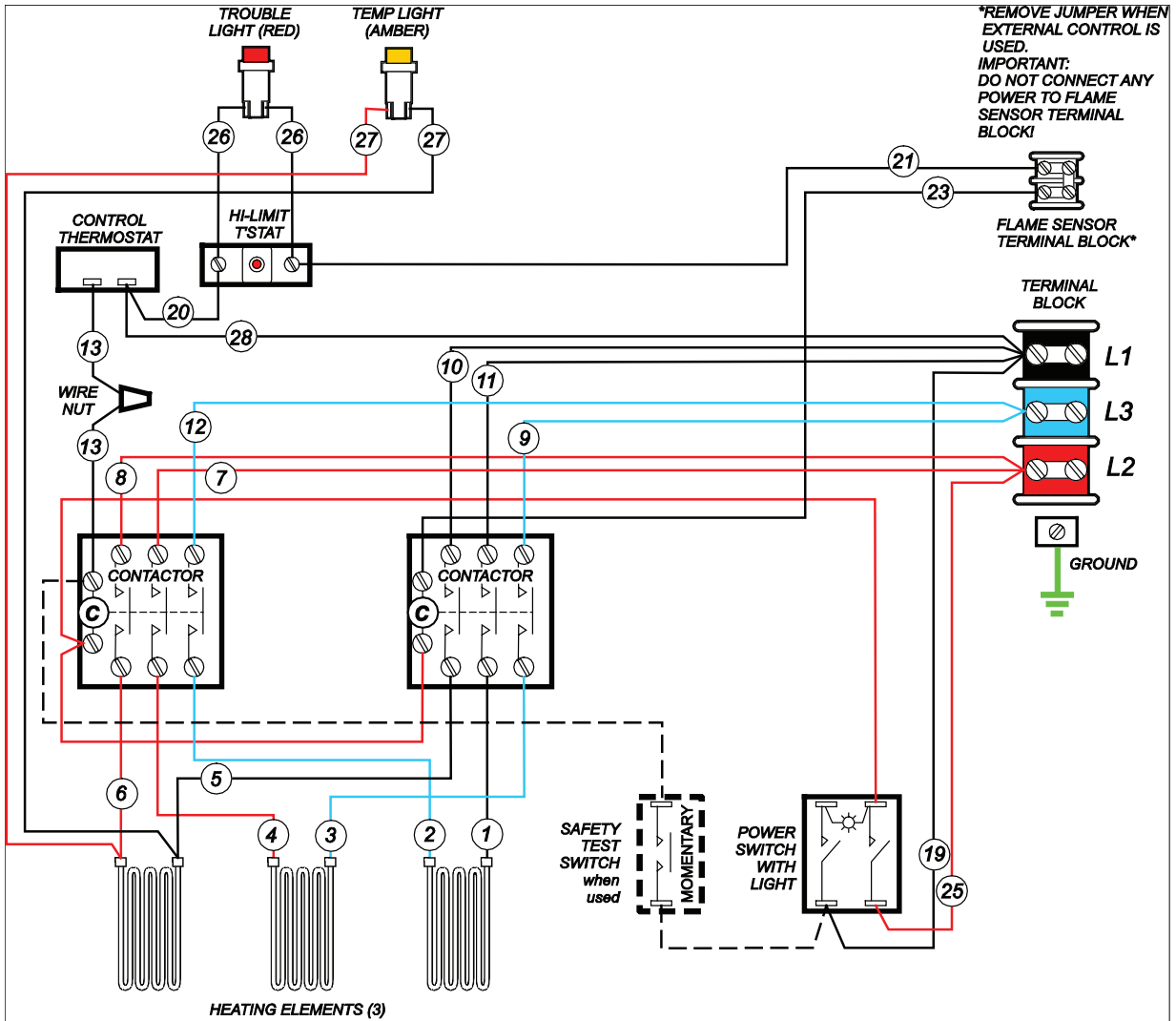

*REMOVE JUMPER WHEN EXTERNAL CONTROL IS USED.
IMPORTANT:
 DO NOT CONNECT ANY POWER TO FLAME SENSOR SENSOR TERMINAL BLOCK!

FRYER F-1725

VOLTS (50/60 HZ)	AMPS 3 PHASE		
	L1	L2	L3
208	47.8	47.8	47.8
240	41.5	41.5	41.5

WIRING DIAGRAM F-1725 p/n 40507

NOTES

DESCRIPTION

PART NO.

FRY BASKET, HALF-SIZE, ALL EXC. F14 and F1725	2B-43688
FRY BASKET, FULL SIZE	2B-43689
FRYPOT, ALL EXCEPT F1725	2D-301344
FRYPOT, F1725	E7-42347
LEGS, ADJUSTABLE METAL	2A-Z0314
LEGS, ADJUSTABLE PLASTIC	2R-Y5092
CRUMB CRADLE, FOR F55, F85	WS-20690
FRY BASKET, HALF-SIZE for F1725	2B-42705
COVER, FRYPOT, ALL EXCEPT F14 and F1725	E7-34421
FRY BASKET, HALF-SIZE, FOR F14	2B-45731
CORDSET, FOR F55 50 AMP 1ø NEMA 6-50P	DD-74897

IMPORTANT: Use only factory authorized service parts and replacement filters. For factory authorized service, or to order factory authorized replacement parts, contact your Wells authorized service agency, or call:

Wells Bloomfield, LLC
 10 Sunnen Dr.
 St. Louis MO 63143 USA

Service Dept.
 phone: (888) 356-5362
 fax: (314) 781-2714

Service Parts Department can supply you with the name and telephone number of the WELLS AUTHORIZED SERVICE AGENCY nearest you.

CUSTOMER SERVICE DATA

please have this information available if calling for service

RESTAURANT _____ LOCATION _____
 INSTALLATION DATE _____ TECHNICIAN _____
 SERVICE COMPANY _____
 ADDRESS _____ STATE _____ ZIP _____
 TELEPHONE NUMBER (____)____-_____

EQUIPMENT MODEL NO. _____
 EQUIPMENT SERIAL NO. _____

VOLTAGE: 120 208 240 1Ø 3Ø



Wells Bloomfield proudly supports CFESA
Commercial Food Equipment Service Association

SERVICE TRAINING - QUALITY SERVICE



CUSTOMER SATISFACTION



WELLS BLOOMFIELD, LLC
10 Sunnen Dr., St. Louis, MO 63143
telephone: 888-356-5362
fax: 314-781-2714
www.wells-mfg.com