



WELLS MANUFACTURING
265 Hobson Street, Smithville, Tennessee 37166
telephone: (877) 242-0270
www.wells-mfg.com

CARTER-HOFFMANN
1551 McCormick Ave, Mundelein, IL 60060
telephone: (800) 323-9793
www.carter-hoffmann.com

KFC PACK LINE

ASSEMBLY INSTRUCTIONS

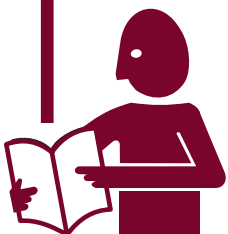
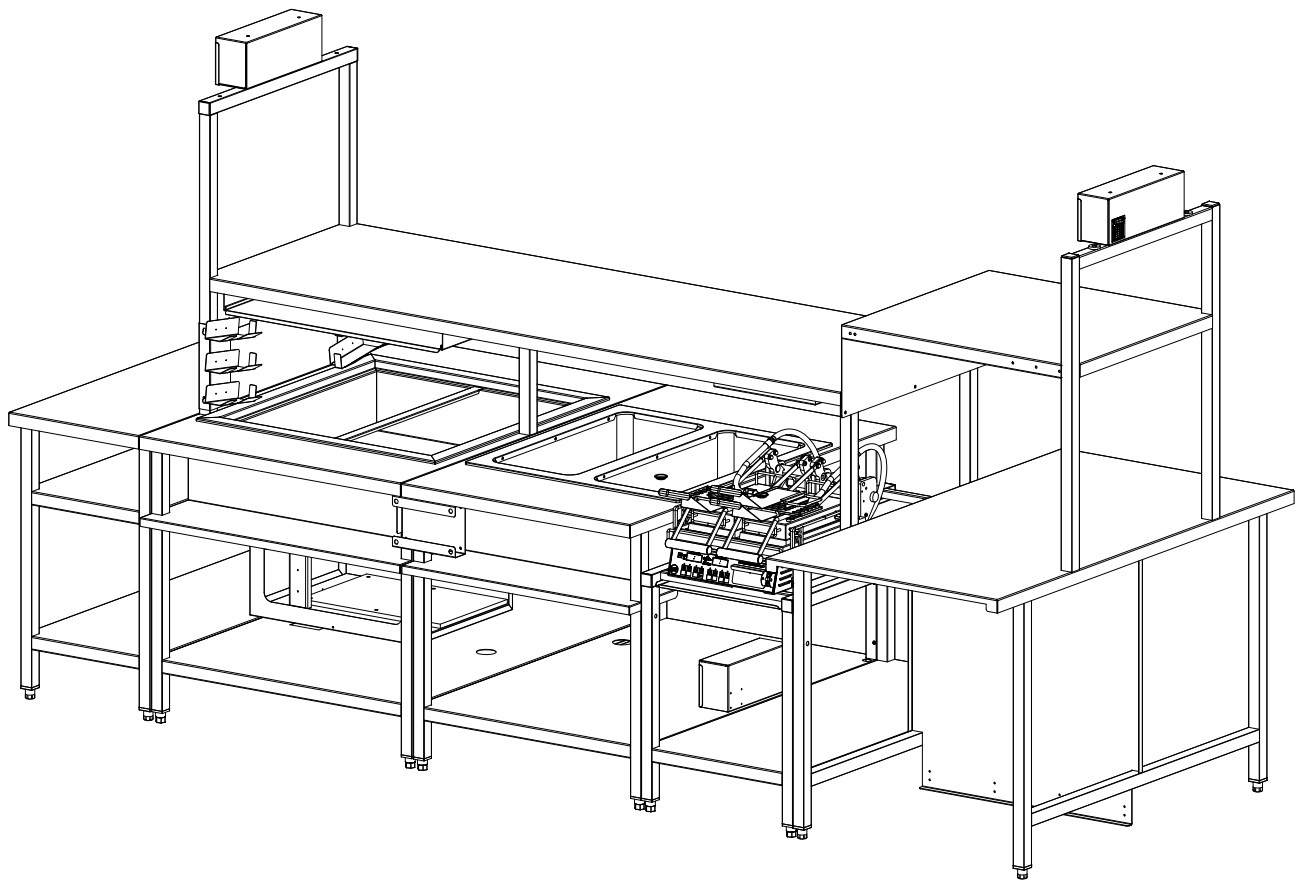

**IMPORTANT: THIS DOCUMENT CONTAINS PROPRIETARY INFORMATION
DISSEMINATION OF THIS INFORMATION TO ANYONE OTHER THAN
AN AUTHORIZED PERSONELL IS STRICTLY PROHIBITED.
TECHNICAL CONTENT OF THIS
MANUAL IS DESIGNED FOR USE BY A QUALIFIED PROFESSIONAL ONLY.**

TABLE OF CONTENTS

RECEIVING THE UNIT	1
SPECIFICATIONS	1
TABLE IDENTIFICATION	2
ASSEMBLY PROCEDURES	3 - 15
ELECTRICAL BOX SPECIFICATIONS	16 - 18

Thank you for purchasing this Wells Manufacturing appliance.

Proper installation, professional operation and consistent maintenance of this appliance will ensure that it gives you the very best performance and a long, economical service life.

This manual contains the information needed to properly install this appliance in a manner which will ensure its optimum performance.

RECEIVING THE UNIT

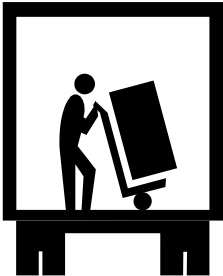

RECEIVING THE UNIT

First and foremost, each crate should be examined before signing the Bill of Lading to report any visible damage by the trucker in transit and to account for the proper number of crates. If there is apparent damage, arrangements should be made to file a claim against the carrier.

SPECIFICATIONS

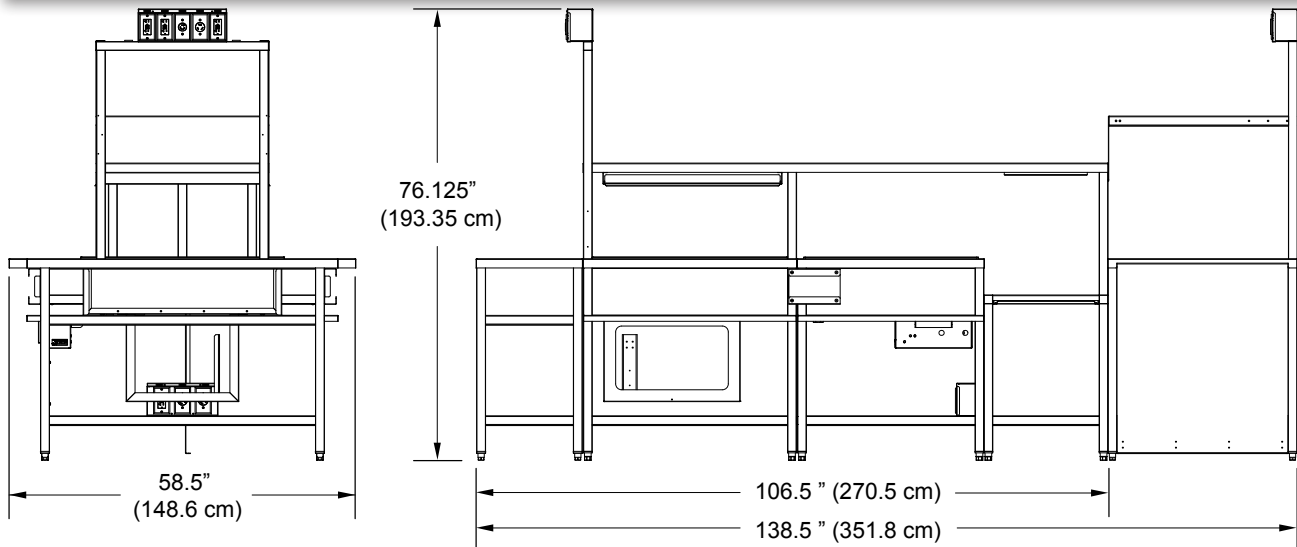
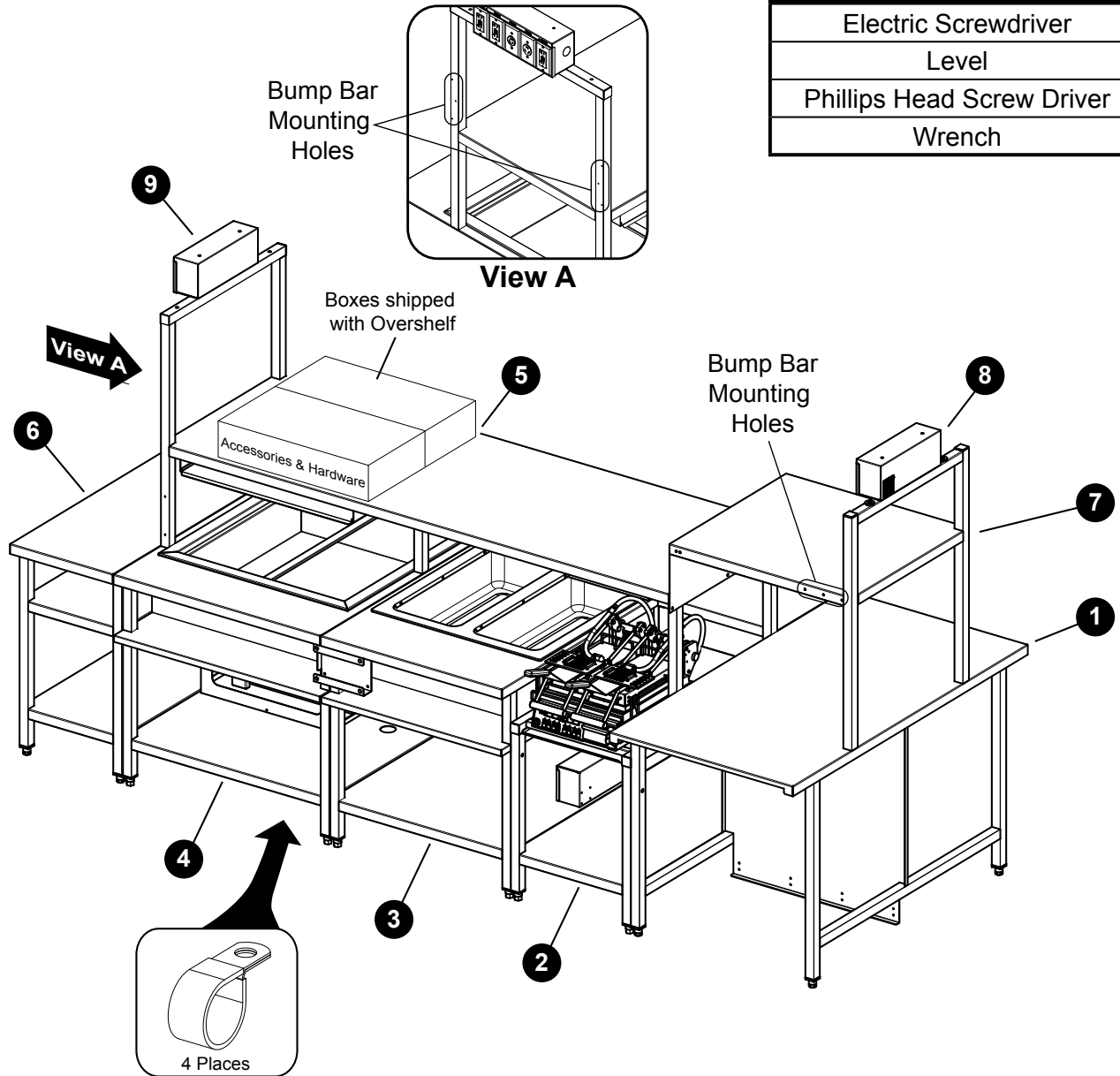

TABLE IDENTIFICATION



TOOLS NEEDED
Electric Screwdriver
Level
Phillips Head Screw Driver
Wrench

KFC PACKLINE ASSEMBLY			
Item	Part Number	Description	Manufacturer
1	KFCP32	FRY DUMP TABLE	CARTER-HOFFMAN
2	SL-TG4821-K	KFC GRILL TABLE ASSEMBLY	WELLS MANUFACTURING
3	SL-TH5332-K	KFC HOT TABLE ASSEMBLY	WELLS MANUFACTURING
4	SL-TC5336-K	KFC COLD TABLE ASSEMBLY	WELLS MANUFACTURING
5	SL-OS8929-K	KFC OVER SHELF ASSEMBLY	WELLS MANUFACTURING
6	KFCPL18	TOASTER END TABLE	CARTER-HOFFMAN
7	KFCHS	FRY TABLE OVERSHELF	CARTER-HOFFMAN
8	Q3-SL011	ASSEMBLY UPPER ELECT BOX FRY	WELLS MANUFACTURING
9	Q3-SL010	ASSEMBLY UPPER ELECT TOAST	WELLS MANUFACTURING

Step 1

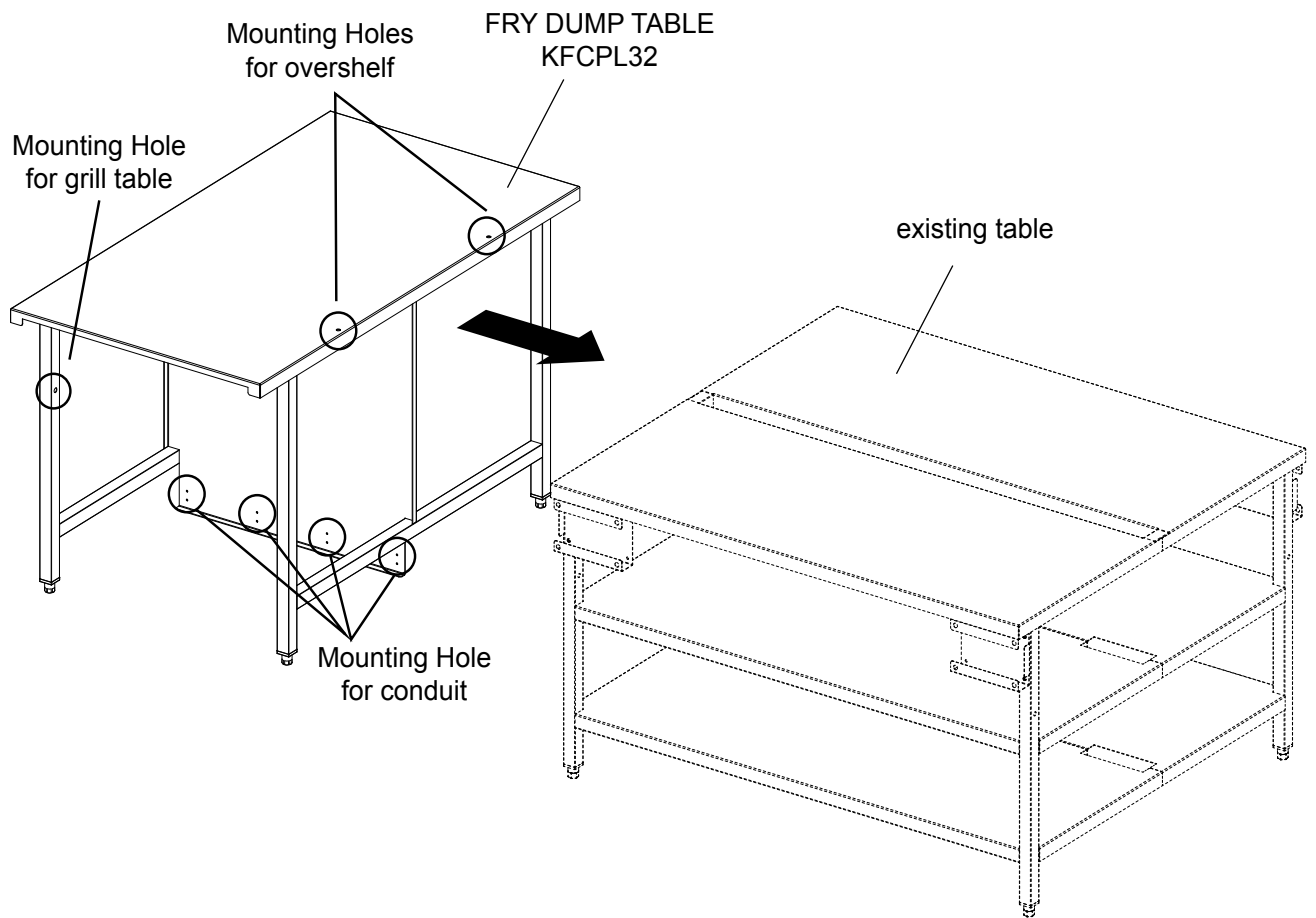

Locate Fry Dump Table



Step 2

Install Grill Table

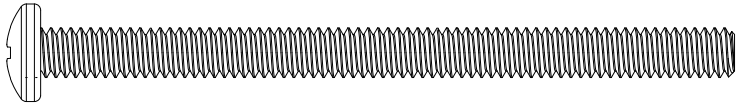
FASTENER PACK SL017 INCLUDES:

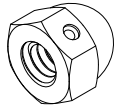
2X	
	2C-Z20123; 1/4"-20 X 3-1/2" PAN HEAD
4X	
	2C-Z19938; WASHER 1/4" FLAT
2X	
	2C-Z18752; LOCKNUT, ACORN, 1/4"-20, SS

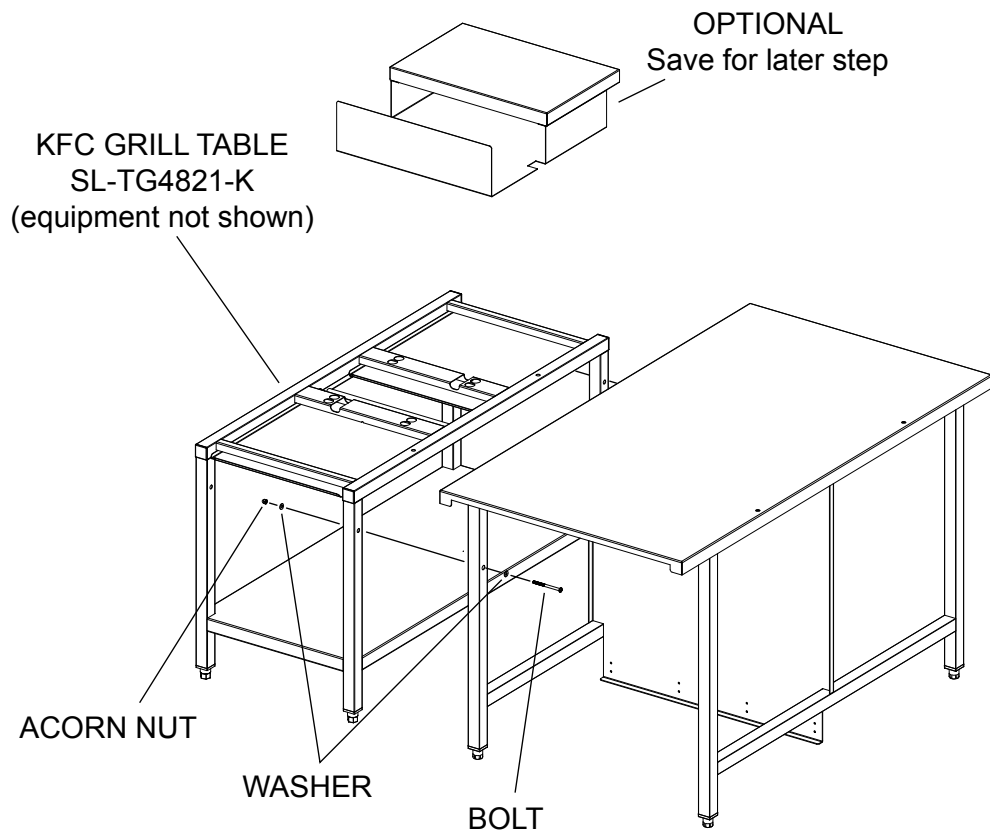

Secure all hardware finger tight until entire table is together.

Step 3

Install Hot Table

FASTENER PACK SL018 INCLUDES:

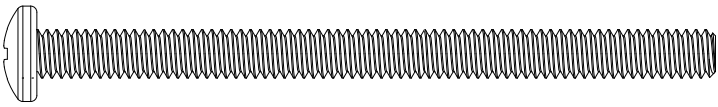
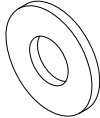
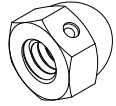
2X	
	2C-Z20123; 1/4"-20 X 3-1/2" PAN HEAD
4X	
	2C-Z19938; WASHER 1/4" FLAT
2X	
	2C-Z18752; LOCKNUT, ACORN, 1/4"-20, SS

HOT TABLE ASSEMBLY
SL-TH5332-K

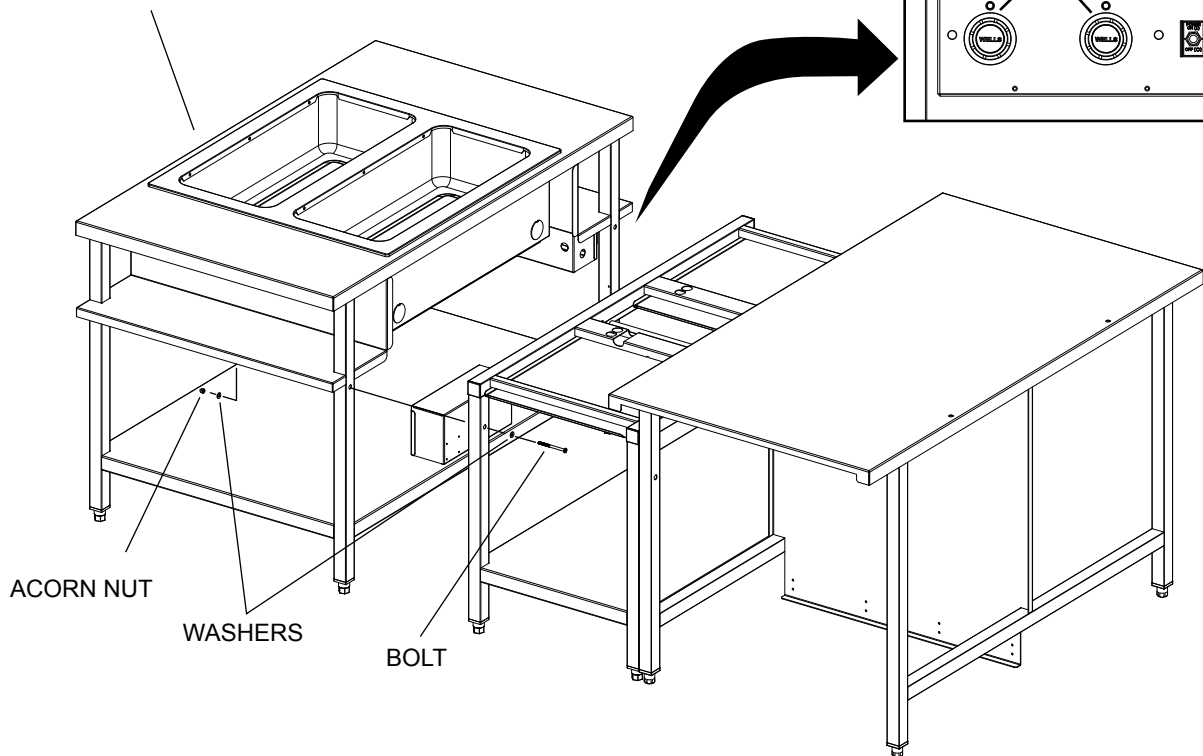

Secure all hardware finger tight until entire table is together.

Step 4

Install Cold Table

FASTENER PACK SL019 INCLUDES:

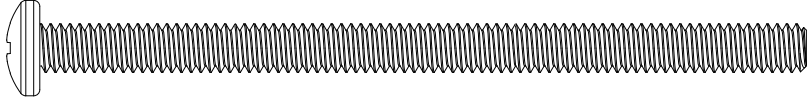
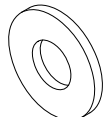
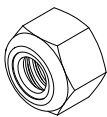
2X	
	2C-Z19939; 1/4"-20 X 4" PAN HEAD
4X	
	2C-Z19938; WASHER 1/4" FLAT
2X	
	2C-53-0009; NUT, 1/4-20, S/S HEX LOCK

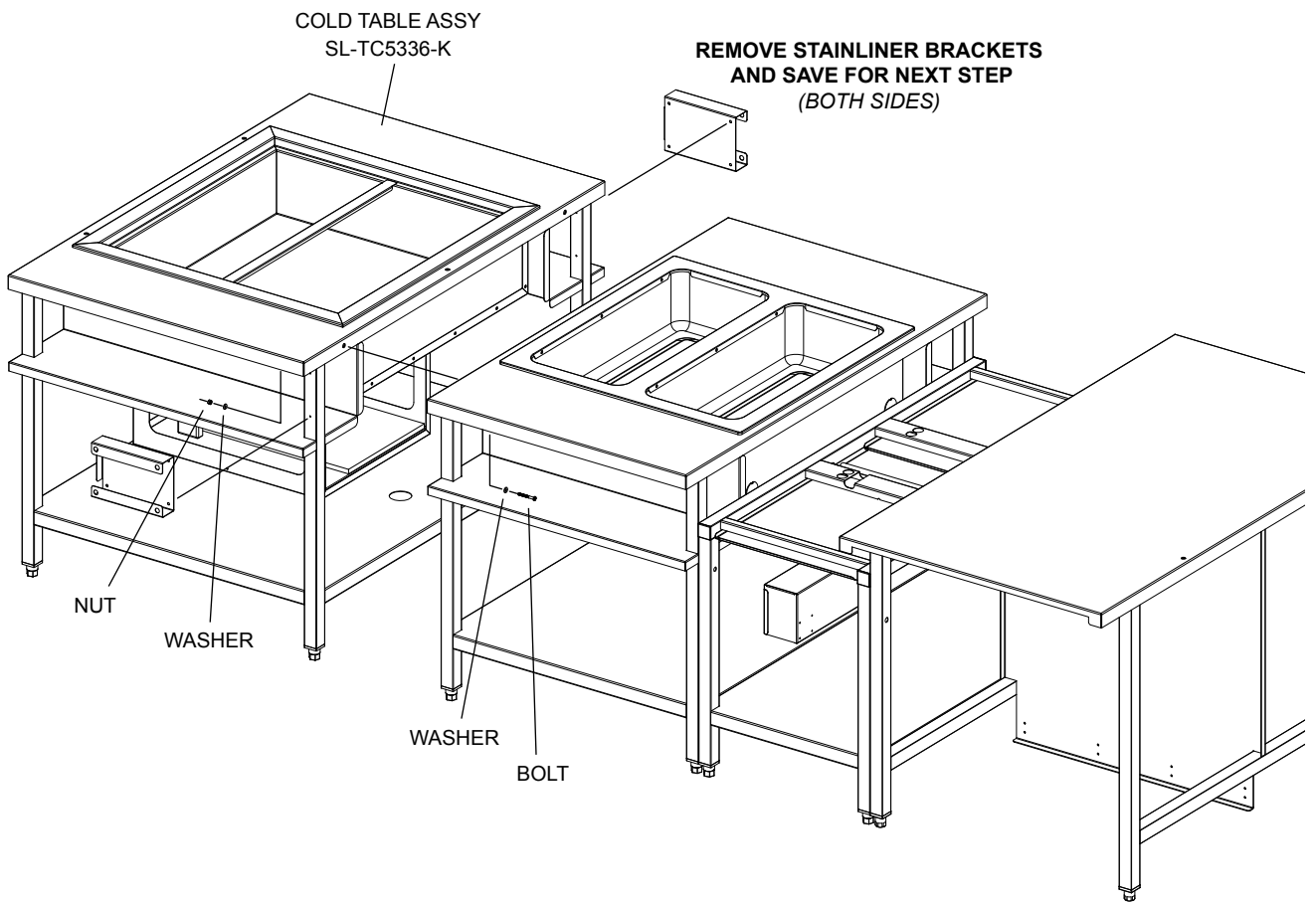

Secure all hardware finger tight until entire table is together.

Step 5

Re-install Stainliner Brackets

HARDWARE & STAINLINER BRACKETS ARE ALREADY INSTALLED DURING SHIPPMENT

4X

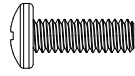

2C-Z19935; 8-32 X 1/2" PHILLIPS TRUSS HEAD

NOTE: Stainliner brackets were shipped backwards for shipment

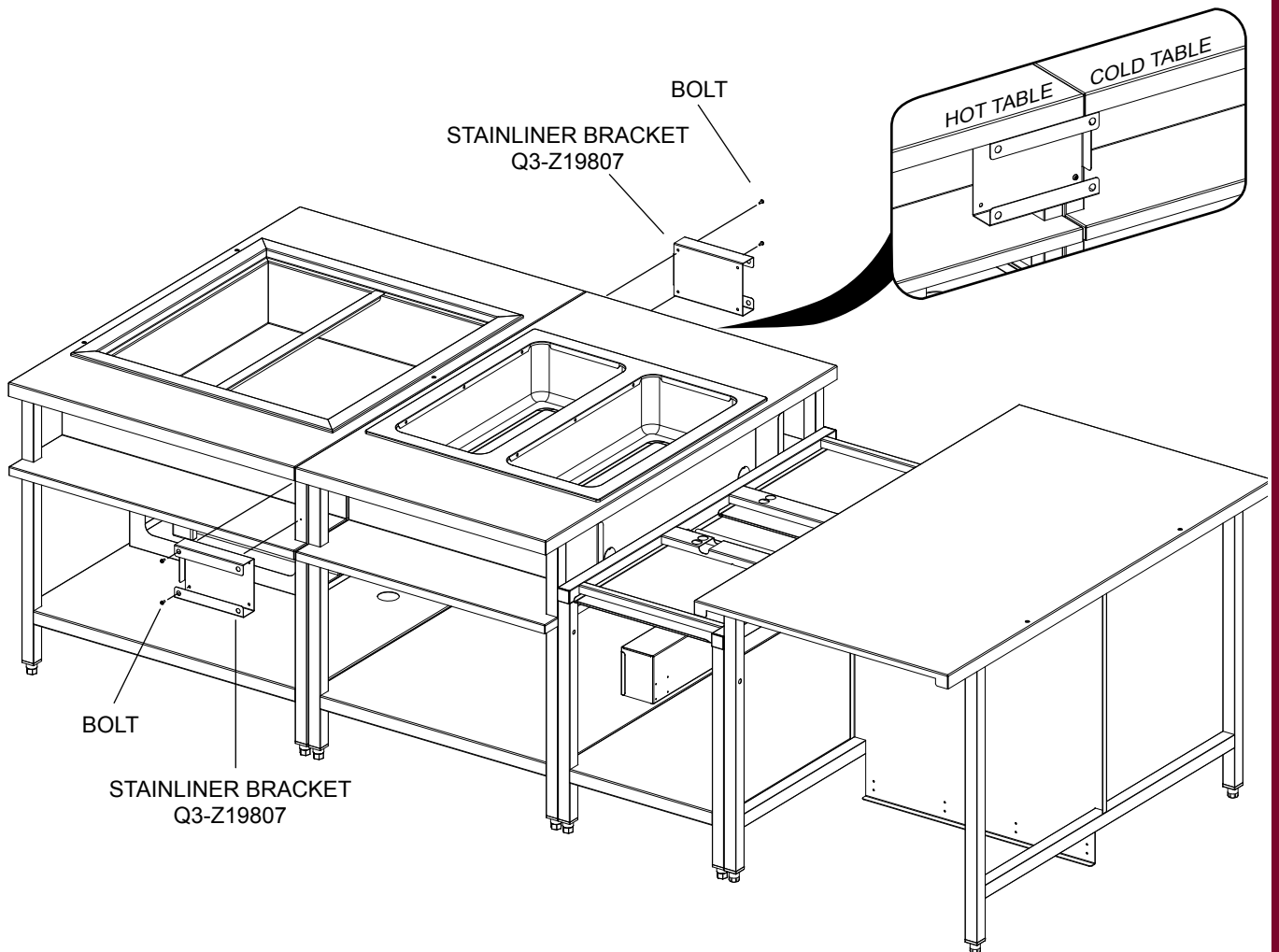

Secure all hardware finger tight until entire table is together.

Step 6

Install Overshelf

FASTENER PACK SL020 INCLUDES:

5X

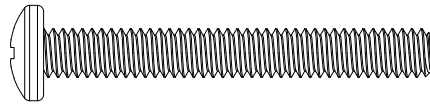

2C-Z19942; 1/4"-20 X 2" PAN HEAD

5X

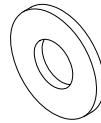

2C-Z19938; WASHER 1/4" FLAT

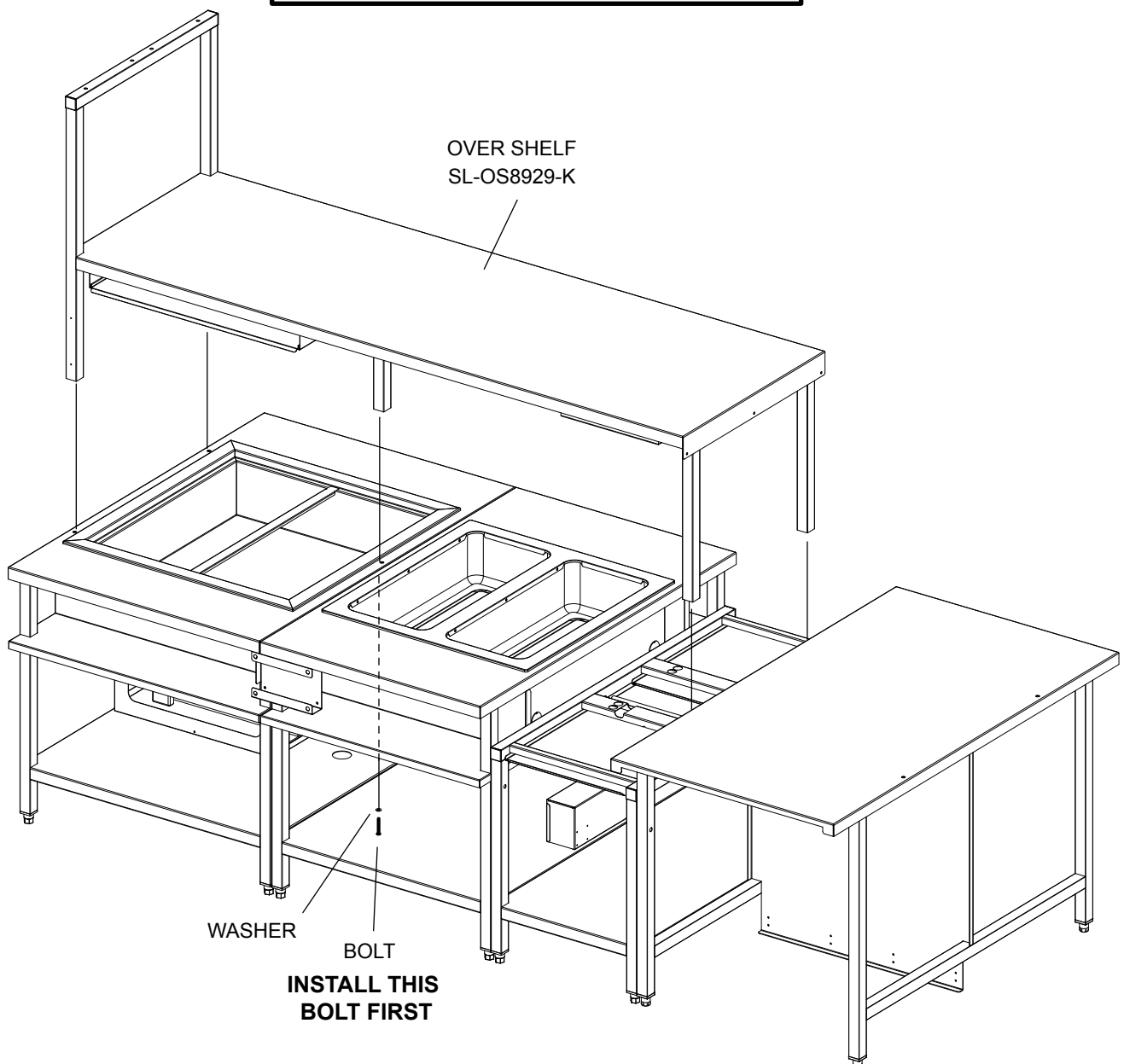

Secure all hardware finger tight until entire table is together.

Step 7

Install Toaster Table

FASTENER PACK SL021 INCLUDES:

2X

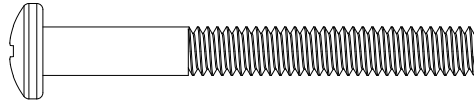

2C-Z19940; 1/4"-20 X 2-1/4" PAN HEAD

4X



2C-Z19938; WASHER 1/4" FLAT

2X

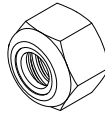

2C-53-0009; NUT, 1/4-20, S/S HEX LOCK

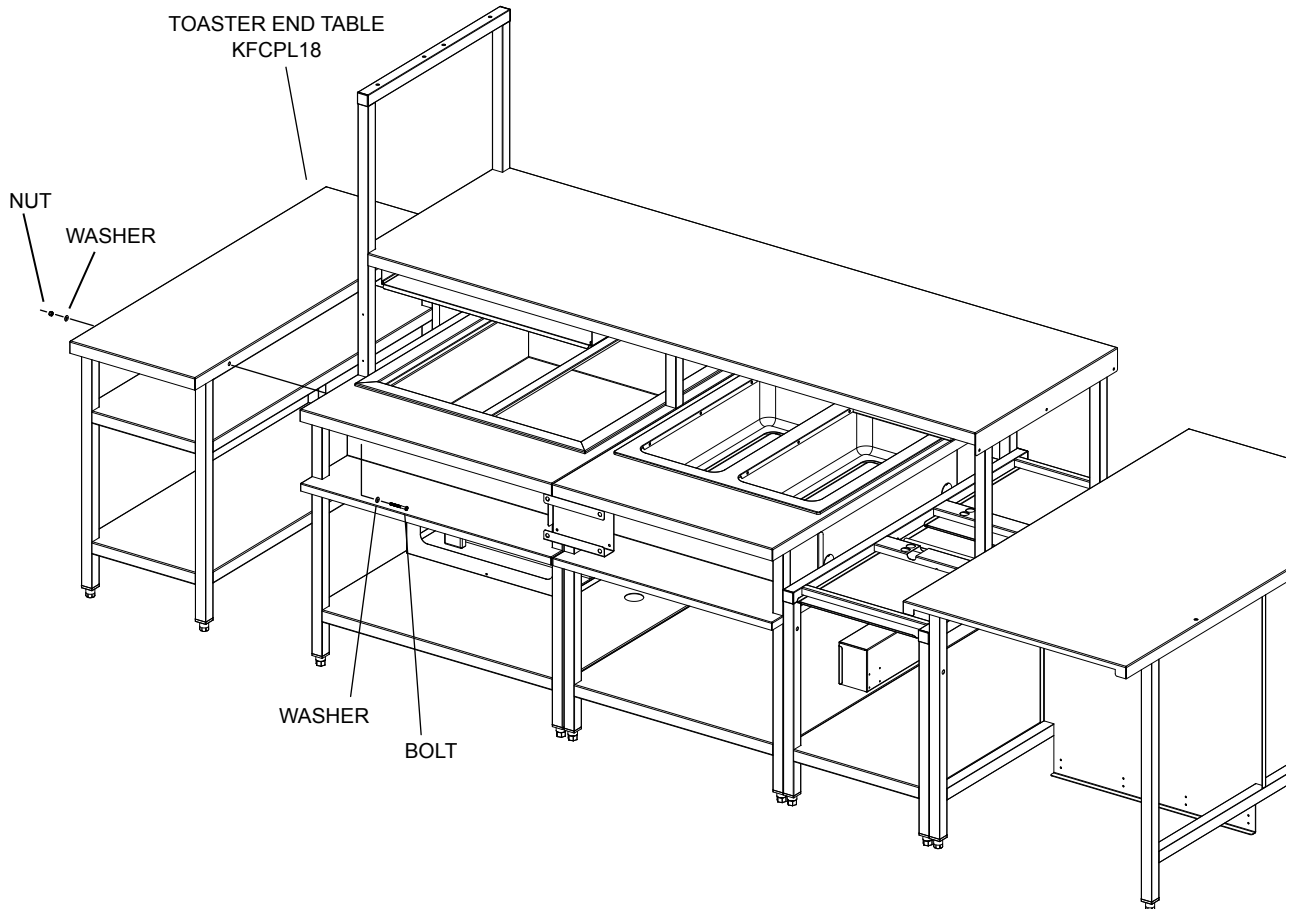

Secure all hardware finger tight until entire table is together.

Step 8

Install Fry Table Overshelf

FASTENER PACK SL022 INCLUDES:

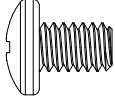
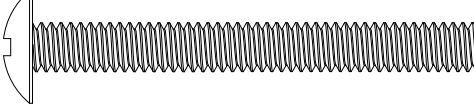
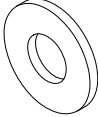
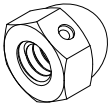
3X  2C-Z19941; 1/4"-20 X 3/8" PAN HEAD	2X  2C-Z19940; 1/4"-20 Thread, 2-1/4" Length
5X  2C-Z19938; WASHER 1/4" FLAT	3X  2C-Z18752; LOCKNUT, ACORN, 1/4"-20, SS

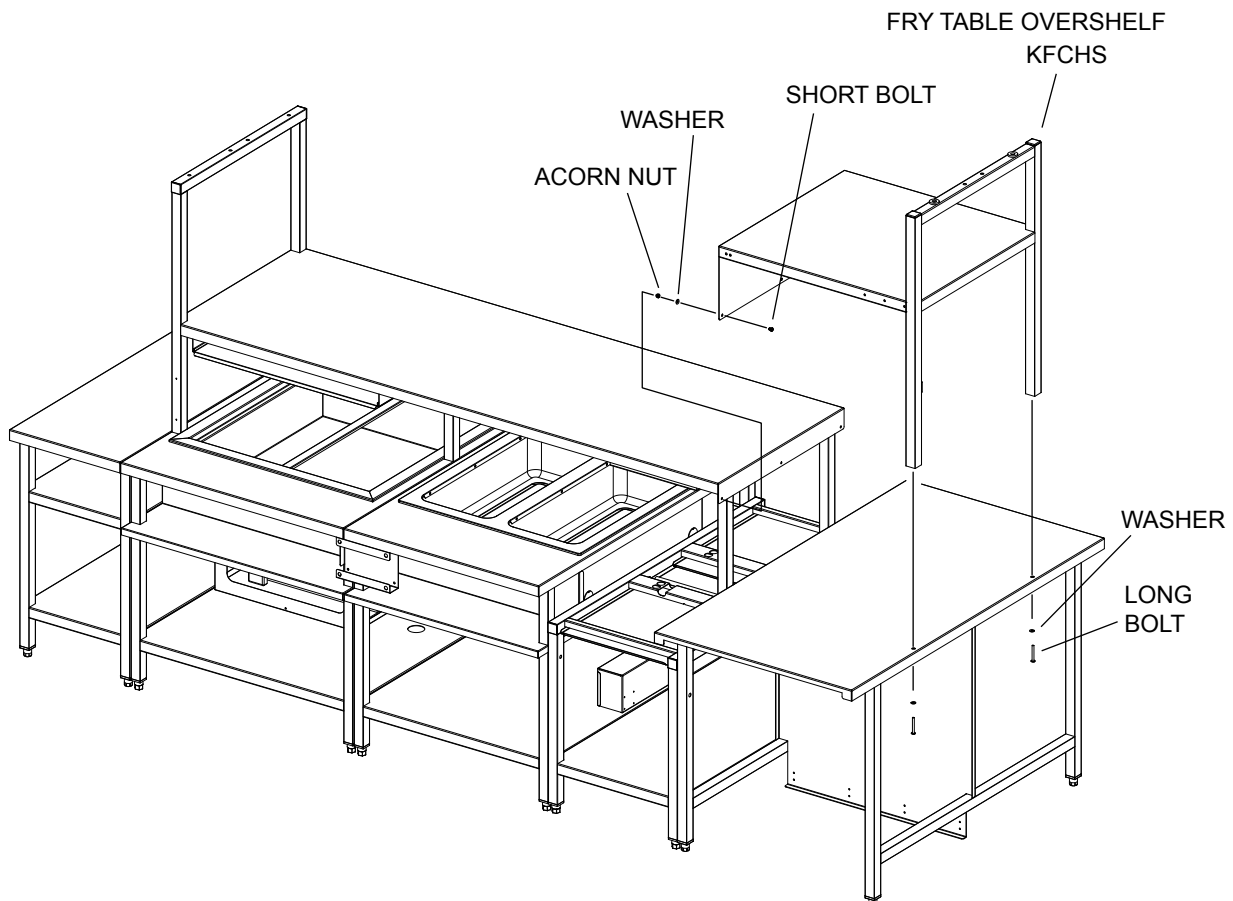

Secure all hardware finger tight until entire table is together.

Step 9

Install Electrical Box

FASTENER PACK SL023 INCLUDES:

2X

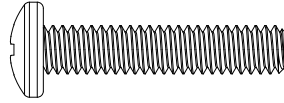

2C-Z20034; 1/4"-20 X 1-1/4" PAN HEAD

2X



2C-Z19938; WASHER 1/4" FLAT

2X

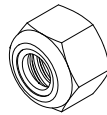

2C-53-0009; NUT, 1/4-20, S/S HEX LOCK

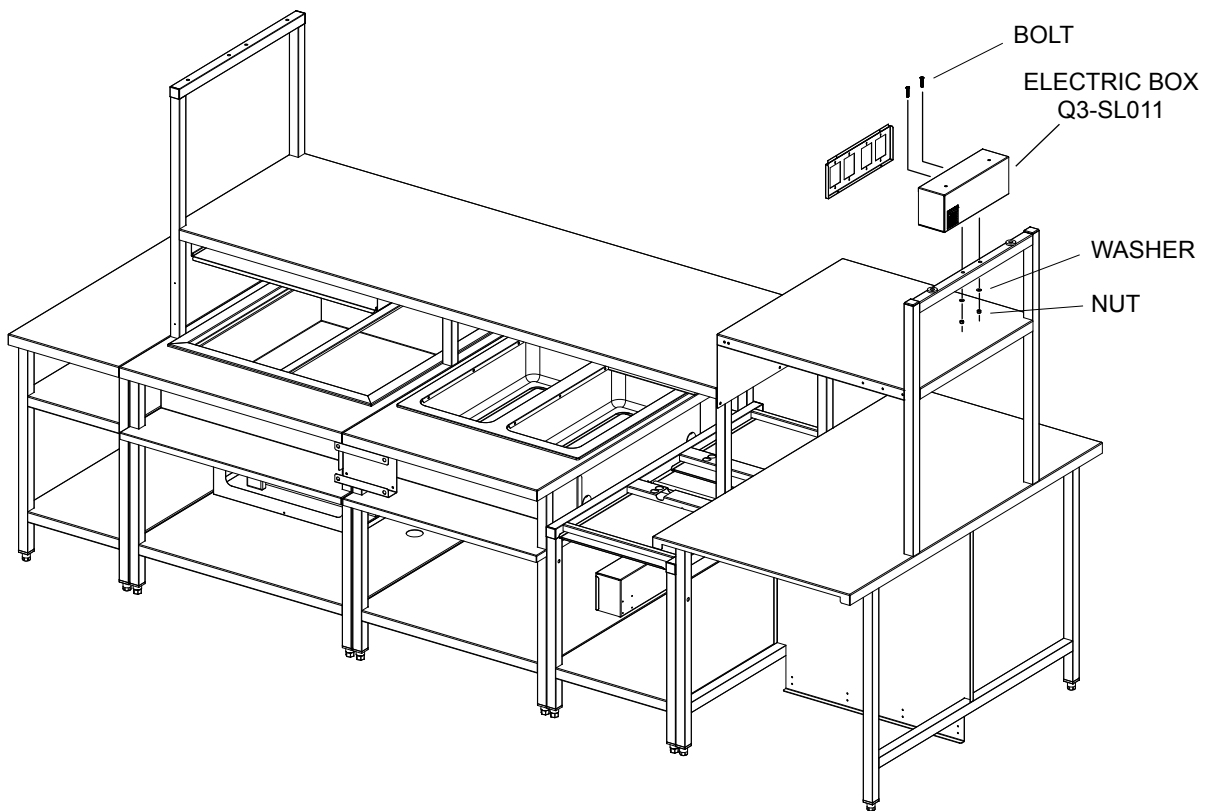

Note: Refer to electrical boxes for electrical components.

Step 10

Install Electrical Box

FASTENER PACK SL024 INCLUDES:

2X

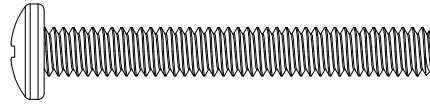

2C-Z19942; 1/4"-20 X 2" PAN HEAD

2X



2C-Z19938; WASHER 1/4" FLAT

2X

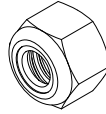

2C-53-0009; NUT, 1/4-20, S/S HEX LOCK

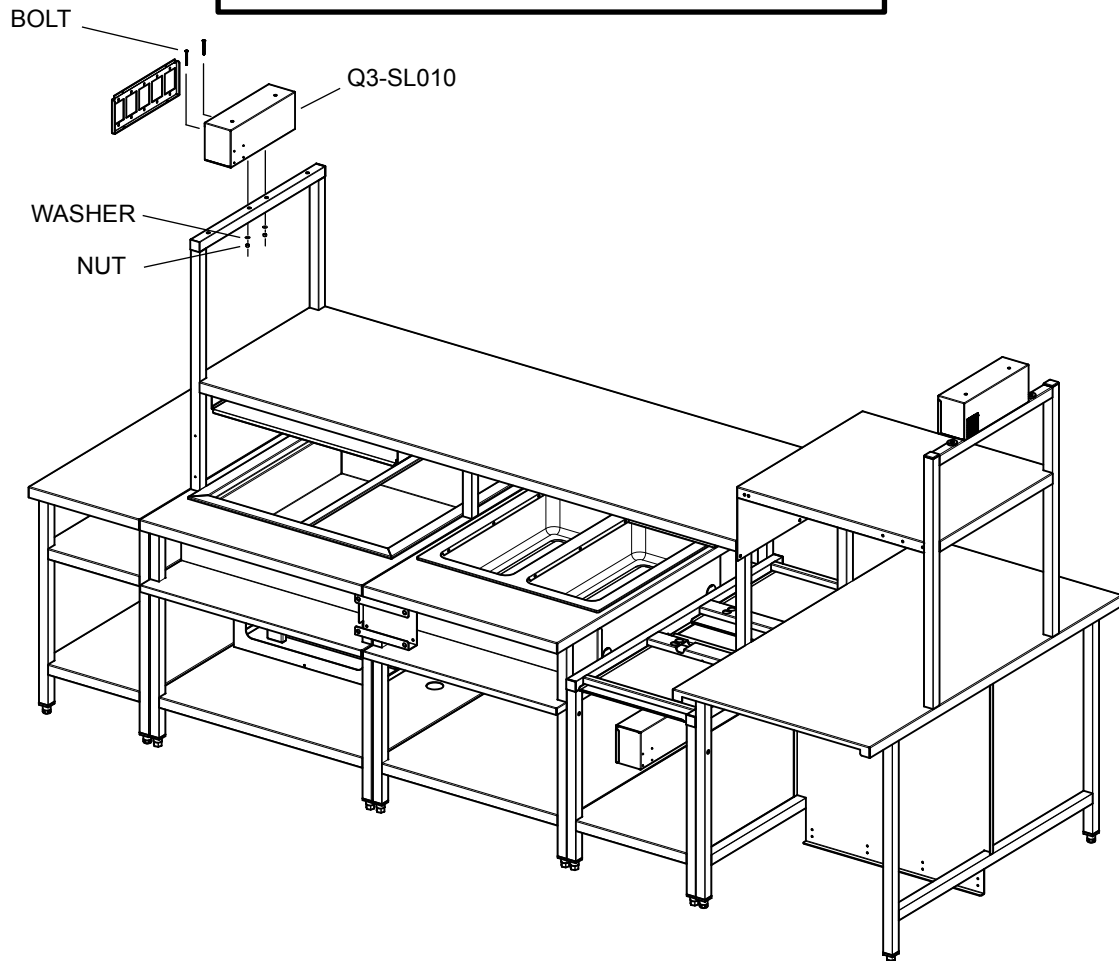

Note: Refer to electrical boxes for electrical components.

Step 11

Locate Star Grills and Tray Slides

FASTENER PACK SL025 INCLUDES:

Snub Nose Style
front holes

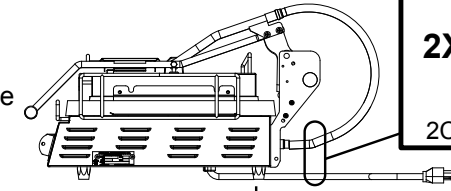

2X

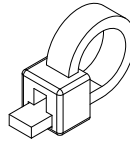

2C-Z3841; CABLE TIE

45° Nose Style
rear holes

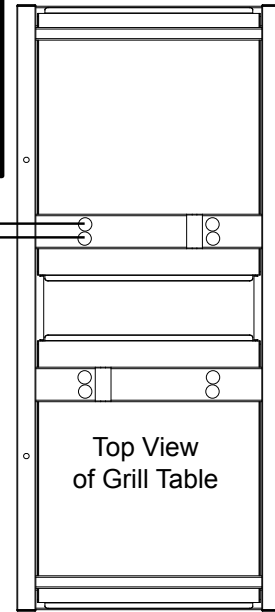
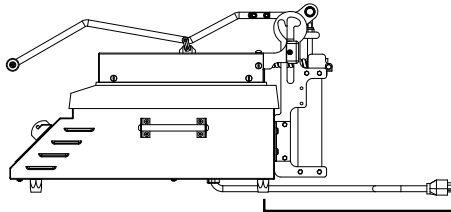

Tray Slide is used
when only one
grill is needed.

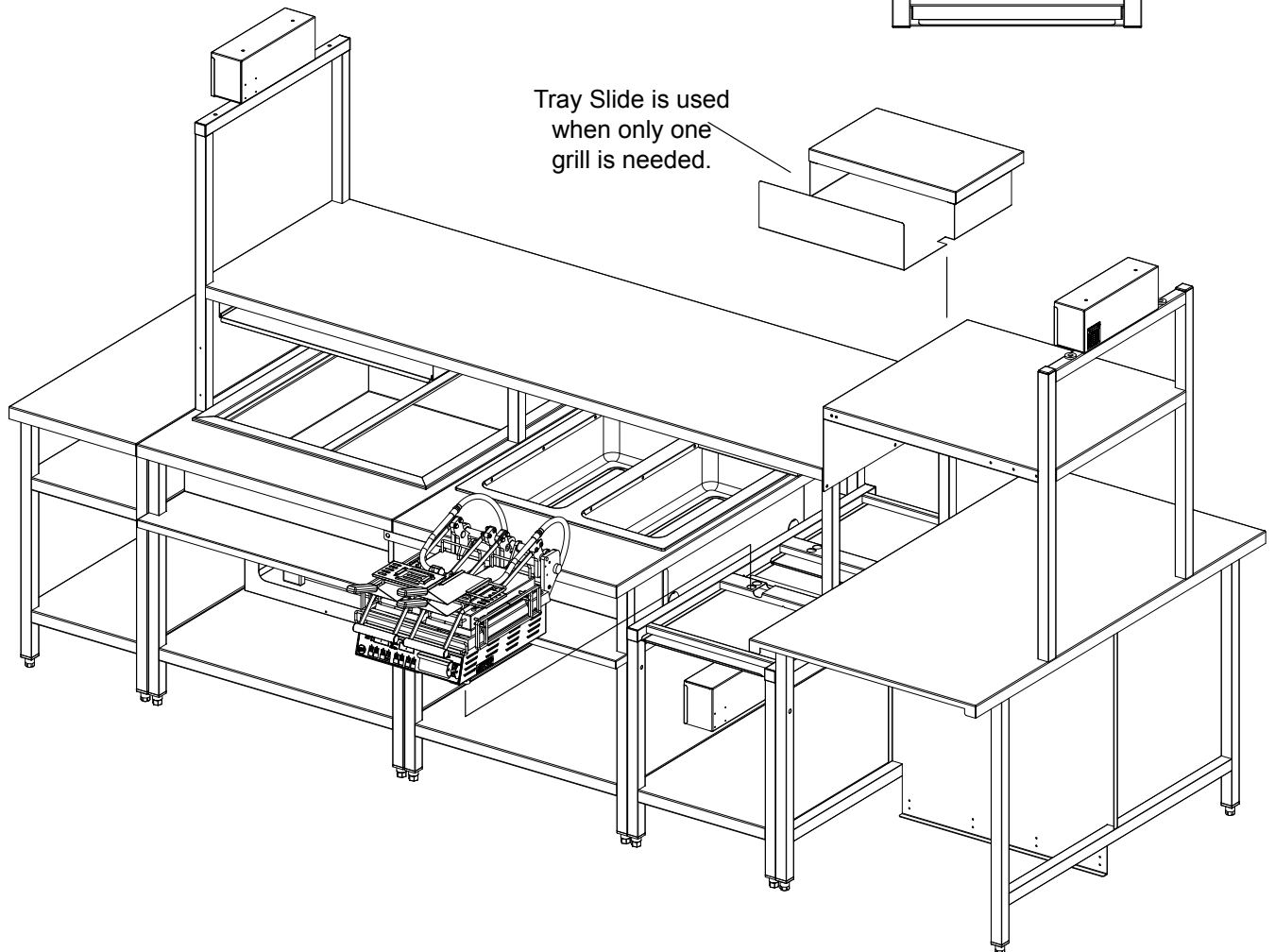
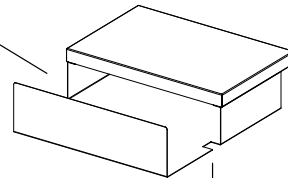

Step 12

Install Bottle Brackets

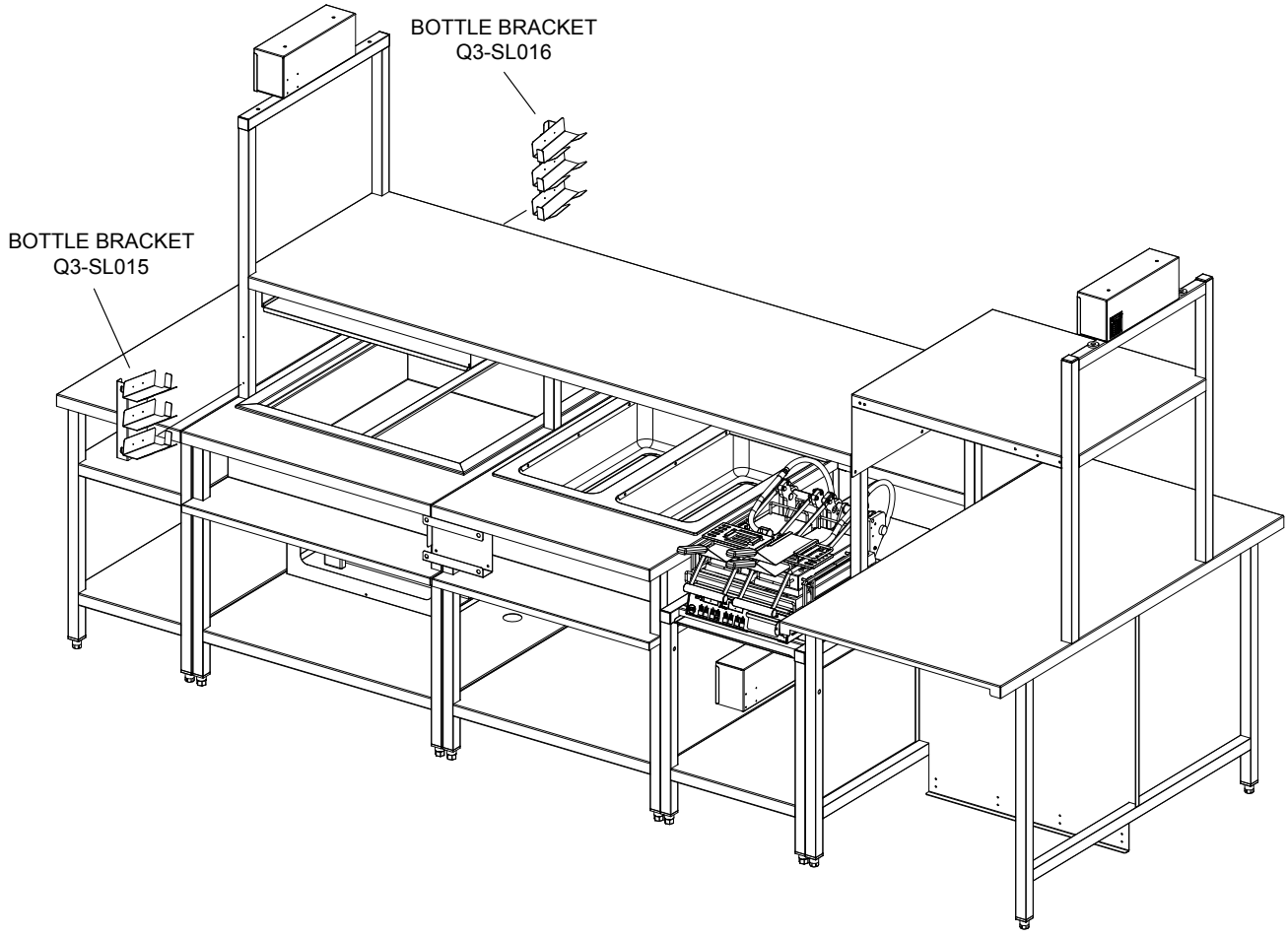

Step 13

Level and Tighten

IMPORTANT: Once all tables are together, level unit & tighten all hardware previously installed.

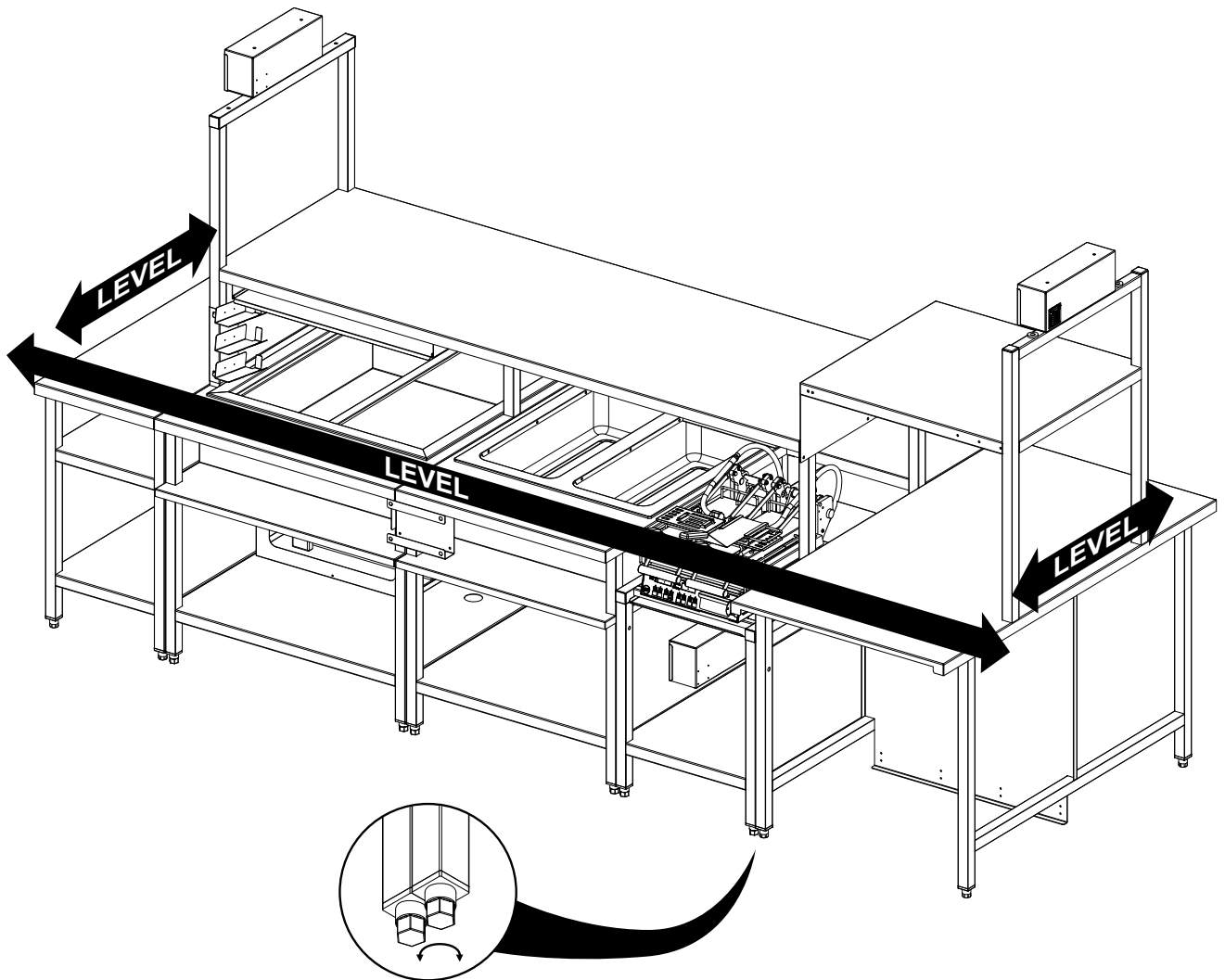



STAR MANUFACTURING INTERNATIONAL INC.
265 HOBSON STREET
SMITHVILLE, TENNESSEE 37166 U.S.A.

MATERIAL	MODEL NO.
FINISH	SL-KFC
DR. mhuegerich	DATE: 12/1/2014
TOLERANCE UNLESS NOTED: .015 ANGLES 1-	

PART NO. 2M-Z19825 PG. 1

TITLE
LOWER ELECTRICAL PANEL ASSEMBLY

THIS DRAWING CONTAINS INFORMATION CONFIDENTIAL TO STAR MFG. INT'L. INC. NO REPRODUCTION OR DISCLOSURE OF ITS CONTENTS IS PERMITTED REVISIONS LTR DATE DESCRIPTION OF CHANGE DR

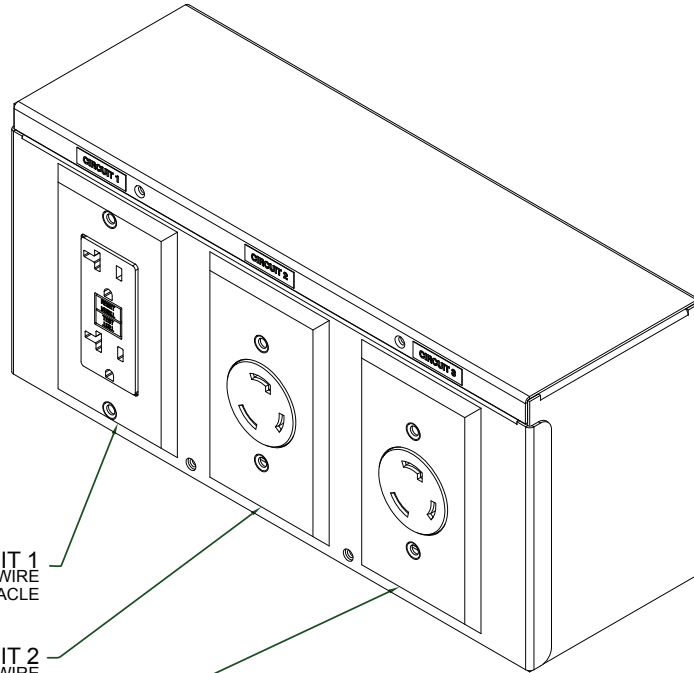

REFRIGERATORS - CIRCUIT 1
120 VOLT, 20 AMP, SINGLE PHASE, 2 WIRE
GFCI DUPLEX RECEPTACLE

SPLIT TOP SANDWICH GRILL - CIRCUIT 2
120 VOLT, 30 AMP, SINGLE PHASE, 2 WIRE
NEMA L5-30R

SPLIT TOP SANDWICH GRILL - CIRCUIT 3
120 VOLT, 30 AMP, SINGLE PHASE, 2 WIRE
NEMA L5-30R



STAR MANUFACTURING INTERNATIONAL INC.
265 HOBSON STREET
SMITHVILLE, TENNESSEE 37166 U.S.A.

MATERIAL	MODEL NO.
FINISH	SL-KFC
DR. mhuegerich	DATE: 12/1/2014
TOLERANCE UNLESS NOTED: .015 ANGLES 1-	

PART NO. 2M-Z19825 PG. 2

TITLE
KFC PACKLINE ASSY.

THIS DRAWING CONTAINS INFORMATION CONFIDENTIAL TO STAR MFG. INT'L. INC. NO REPRODUCTION OR DISCLOSURE OF ITS CONTENTS IS PERMITTED REVISIONS LTR DATE DESCRIPTION OF CHANGE DR

A	3-15-2015 ECO# 14534	REMOVED EXTRA COMPONENTS FROM AROUND ELEC PANEL ASSY.	BKB
---	-------------------------	--	-----

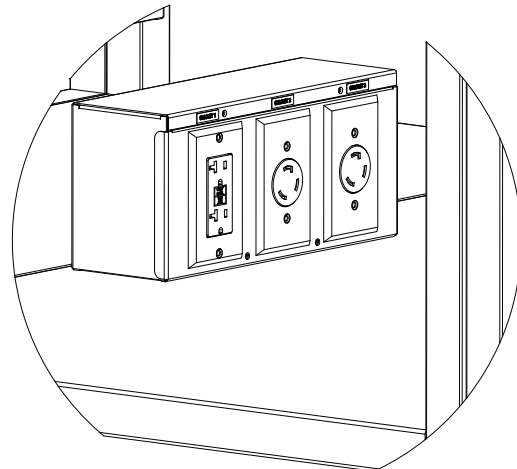
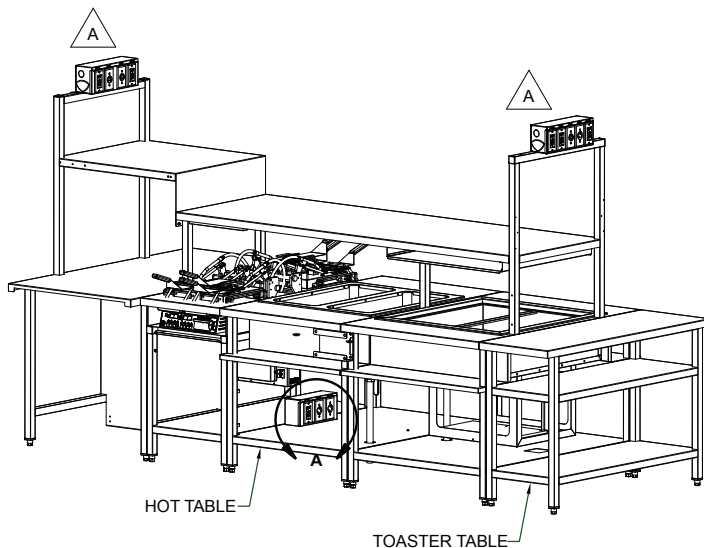

DETAIL A
SCALE .250
RECEPTACLES OF LOWER BOX
FACE TO SIDE AS SHOWN



STAR MANUFACTURING INTERNATIONAL INC.
265 HOBSON STREET
SMITHVILLE, TENNESSEE 37166 U.S.A.

MATERIAL	MODEL NO.	PART NO.
FINISH	SL-KFC	2M-Z19826 PG. 1
DR. mhuegerich	DATE: 1/17/2015	TOLERANCE UNLESS NOTED: .015 ANGLES

TITLE			
UPPER ELECTRICAL BOX/COMM HOLDER			
LTR	DATE	DESCRIPTION OF CHANGE	DR
B	3-31-2015 ECO# 14596	PICTORIAL CHANGE TO SHOW KNOCK-OUTS ON TOP OF BOX	MH

THIS DRAWING CONTAINS INFORMATION CONFIDENTIAL TO STAR MFG. INT'L. INC. NO REPRODUCTION OR DISCLOSURE OF ITS CONTENTS IS PERMITTED REVISIONS

NOTE:
BEFORE INSTALLING OUTLETS,
REMOVE FRONT PANEL AND INSTALL
ELECTRICAL BOX TO END SHELF
UPRIGHT AS SHOWN ON PG 2
USING THE FASTENERS PROVIDED

MONITOR/COMMUNICATION - CIRCUIT 1
120 VOLT, 15AMP, SINGLE PHASE, 2 WIRE
ORANGE GFCI DUPLEX RECEPTACLE - GROUND ISOLATED

FRY DUMP - CIRCUIT 2
208 VOLT, 20 AMP, SINGLE PHASE, 2 WIRE
NEMA 6-20R

 SIDES HOLDING CABINET - CIRCUIT 3
120 VOLT, 15 AMP, SINGLE PHASE, 2 WIRE
NEMA L6-15R

MONITOR/COMMUNICATION - CIRCUIT 4
120 VOLT, 20 AMP, SINGLE PHASE, 2 WIRE
ORANGE GFCI DUPLEX RECEPTACLE - GROUND ISOLATED

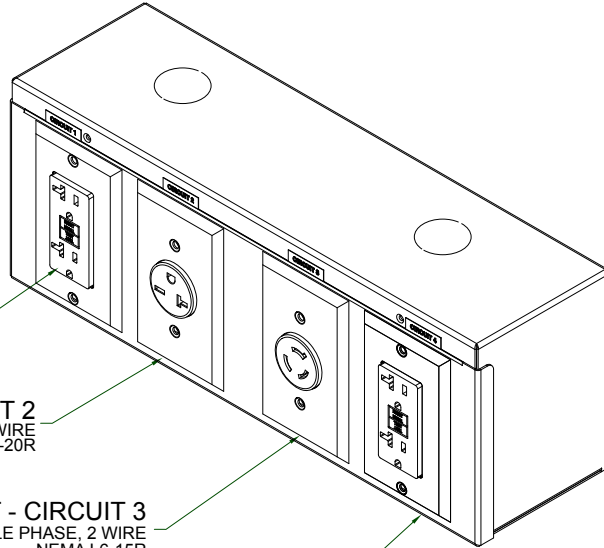

STAR MANUFACTURING INTERNATIONAL INC.
265 HOBSON STREET
SMITHVILLE, TENNESSEE 37166 U.S.A.

MATERIAL	MODEL NO.	PART NO.
FINISH	SL-KFC	2M-Z19826 PG. 2
DR. mhuegerich	DATE: 1/17/2015	TOLERANCE UNLESS NOTED: .015 ANGLES

TITLE			
KFC PACKLINE ASSY.			
LTR	DATE	DESCRIPTION OF CHANGE	DR
B	3-31-2015 ECO# 14596	PICTORIAL CHANGE TO SHOW KNOCK-OUTS ON TOP OF BOX	MH

THIS DRAWING CONTAINS INFORMATION CONFIDENTIAL TO STAR MFG. INT'L. INC. NO REPRODUCTION OR DISCLOSURE OF ITS CONTENTS IS PERMITTED REVISIONS

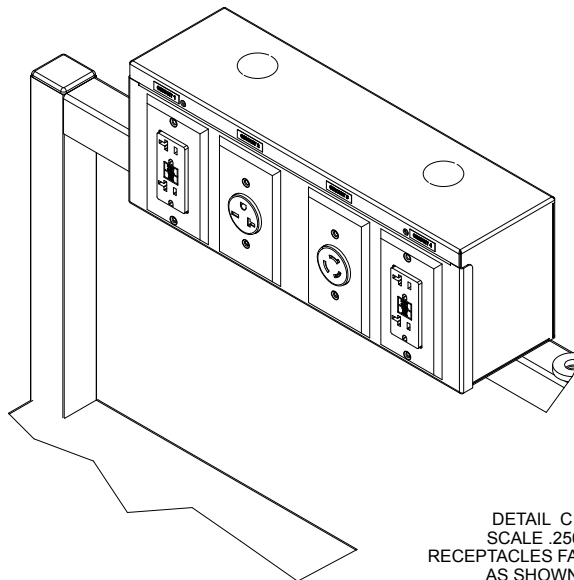
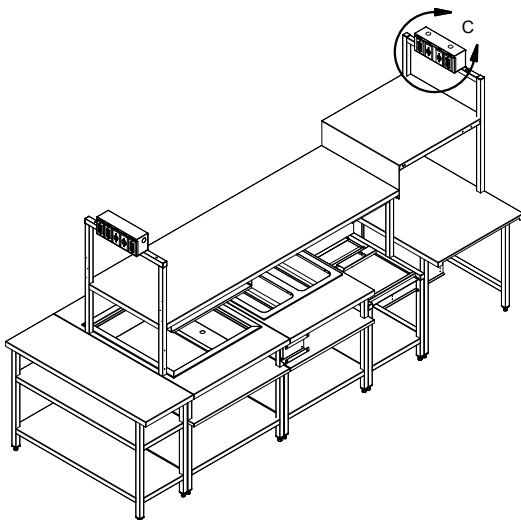

DETAIL C
SCALE .250
RECEPTACLES FACE OUT
AS SHOWN



STAR MANUFACTURING INTERNATIONAL INC.
265 HOBSON STREET
SMITHVILLE, TENNESSEE 37166 U.S.A.

MATERIAL	FINISH	DR. mhuegerich	DATE: 1/17/2015	TOLERANCE UNLESS NOTED: .015 ANGLES ±
----------	--------	----------------	-----------------	---------------------------------------

MODEL NO. SL-KFC	PART NO. 2M-Z19827 PG. 1		
TITLE UPPER ELECTRICAL BOX - TOASTER			
LTR	DATE	DESCRIPTION OF CHANGE	DR
B	3-31-2015 ECO# 14596	PICTORIAL CHANGE TO SHOW KNOCK-OUTS ON TOP OF BOX	MH

THIS DRAWING CONTAINS INFORMATION CONFIDENTIAL TO STAR MFG. INTL. INC. NO REPRODUCTION OR DISCLOSURE OF ITS CONTENTS IS PERMITTED REVISIONS

MONITOR/COMMUNICATION - CIRCUIT 1
120 VOLT, 15 AMP, SINGLE PHASE, 2 WIRE
ORANGE GFCI DUPLEX RECEPTACLE - GROUND ISOLATED

CONTACT TOASTER - CIRCUIT 2
120 VOLT, 15 AMP, SINGLE PHASE, 2 WIRE
IVORY GFCI DUPLEX RECEPTACLE

BUN HOLDING CABINET - CIRCUIT 3
208 VOLT, 15 AMP, SINGLE PHASE, 2WIRE
NEMA L6-15R

WARMING/HOLDING UNIT - CIRCUIT 4
208 VOLT, 20 AMP, SINGLE PHASE, 2WIRE
NEMA L6-20R

MONITOR/COMMUNICATION - CIRCUIT 5
120 VOLT, 15 AMP, SINGLE PHASE, 2 WIRE
ORANGE GFCI DUPLEX RECEPTACLE - GROUND ISOLATED

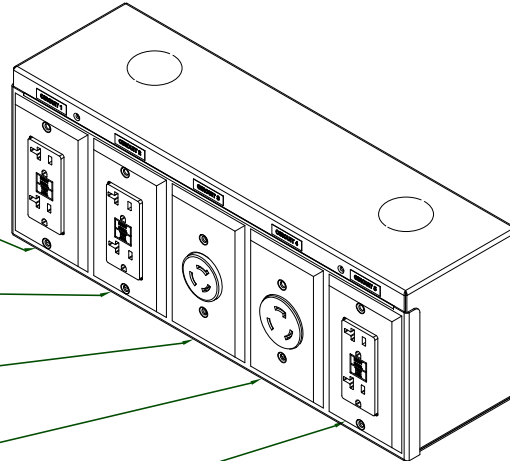

STAR MANUFACTURING INTERNATIONAL INC.
265 HOBSON STREET
SMITHVILLE, TENNESSEE 37166 U.S.A.

MATERIAL	FINISH	DR. mhuegerich	DATE: 1/17/2015	TOLERANCE UNLESS NOTED: .015 ANGLES ±
----------	--------	----------------	-----------------	---------------------------------------

MODEL NO. SL-KFC	PART NO. 2M-Z19827 PG. 2		
TITLE KFC PACKLINE ASSY.			
LTR	DATE	DESCRIPTION OF CHANGE	DR
B	3-31-2015 ECO# 14596	PICTORIAL CHANGE TO SHOW KNOCK-OUTS ON TOP OF BOX	MH

THIS DRAWING CONTAINS INFORMATION CONFIDENTIAL TO STAR MFG. INTL. INC. NO REPRODUCTION OR DISCLOSURE OF ITS CONTENTS IS PERMITTED REVISIONS

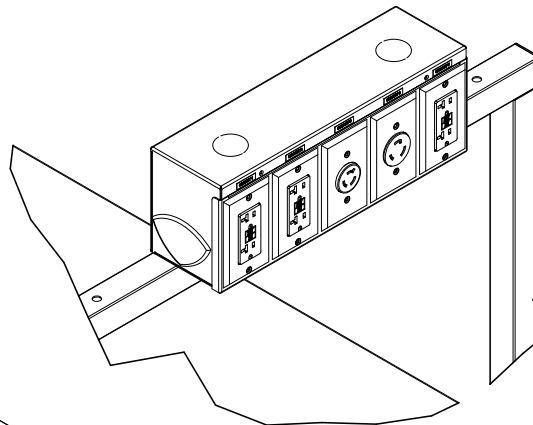
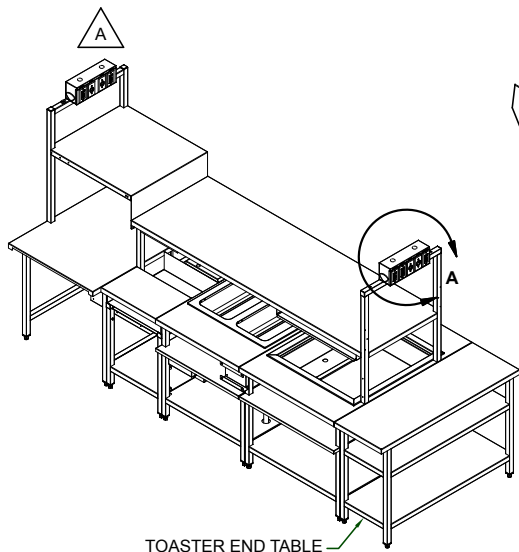

DETAIL A
SCALE .188
RECEPTACLES FACE OUT
AS SHOWN



Wells Bloomfield proudly supports CFESA
Commercial Food Equipment Service Association

SERVICE TRAINING - QUALITY SERVICE



CUSTOMER SATISFACTION



WELLS MANUFACTURING

265 Hobson Street, Smithville, Tennessee 37166

telephone: 314-678-6314

fax: 314-781-2714

www.wells-mfg.com