



Modular Dry Well

Owner's Manual

Models

MDW100, MDW200, MDW300, MDW400, MDW500

This manual includes material related to installation, use, cleaning, and care. Exploded view[s], as well as any available parts list[s] and wiring diagram[s] pertaining to the unit[s] covered by this manual are also included.

This manual must be read and understood by all persons using or installing this appliance. Contact your Wells dealer if you have any questions concerning installation, use, or maintenance of this equipment.

DO NOT DISCARD THIS MANUAL.



LIMITED EQUIPMENT WARRANTY

Wells Manufacturing warrants to the original purchaser of new Wells products to be free from defects in material or workmanship, under normal and proper use and maintenance service as specified by Wells and upon proper installation and start-up in accordance with the instructions supplied with each Wells unit. Wells' obligation under this warranty is limited to a period of one [1] year from the date of original installation, or eighteen [18] months from original invoice date, whichever occurs first. Defects that occur as a result of normal use, within the time period and limitations defined in this warranty, will at Wells' discretion have the parts replaced or repaired by Wells or a Wells-authorized service agency.

THIS WARRANTY IS SUBJECT TO ALL LISTED CONDITIONS

Repairs performed under this warranty are to be performed by a Wells authorized service agency. Wells will not be responsible for charges incurred or service performed by non-authorized repair agencies. In all cases, the nearest Wells-authorized service agency must be used. Wells will be responsible for normal labor charges incurred in the repair or replacement of a warranted product within 50 miles (80.5 km) of an authorized service agency. Time and expense charges for anything beyond that distance will be the responsibility of the owner. All labor will need to be performed during regular service hours. Any overtime premium will be charged to the owner. For all shipments outside the U.S.A. and Canada, please see the International Warranty for specific details. It is the responsibility of the owner to inspect and report any shipping damage claims, hidden or otherwise, promptly following delivery. No mileage or travel charges will be honored on any equipment that is deemed portable. In general, equipment with a cord and plug weighing less than 50 lb. (22.7 kg) is considered portable and should be taken or shipped to the closest authorized service agency, transportation prepaid.

CONTACT

Should you require any assistance regarding the operation or maintenance of any Wells Manufacturing; phone or email our service department. In all correspondence provide the model number and serial number of the unit needing service; include the voltage or gas type.

Normal Business Hours: 8:00 a.m. to 4:30 p.m. Central

Telephone: 800-264-7827 Tech Service Option 2

Email: TechService@partstown.com

www.Wells-Mfg.com

PRODUCTS	PARTS	LABOR
Universal Ventless Hoods (WVU)	1 year	1 year
Canopy Ventless Hoods (WVC)	1 year	1 year
"Cook and Hold" equipment (HW10, HWSMP, LLSC7, LLSC7WA, LLSC11, LLSC11WA)	1 years	1 year
Cast iron grates, burners and burner shields	1 year	
Original Wells parts sold to repair Wells Equipment	90 days	

WARRANTY EXCLUSIONS

THE FOLLOWING WILL NOT BE COVERED UNDER WARRANTY.

Wells' sole obligation under this warranty is limited to either repair or replacement parts, subject to the additional limitations detailed below. This warranty neither assumes nor authorizes any person to assume obligations other than those expressly covered by this warranty.

- Any product which has not been used, maintained, or installed in accordance with the directions published in the appropriate installation sheet and/or owner's manual, including incorrect gas or electrical connection. Wells is not liable for any unit which has been mishandled, abused, misapplied, subjected to harsh chemicals, modified by unauthorized personnel, damaged by flood, fire, or other acts of nature [or God], or which have an altered or missing serial number.
- Installation, labor, and job checkouts, calibration of heat controls, air and gas burner/bypass/pilot adjustments, gas or electrical system checks, voltage and phase conversions, cleaning of equipment, or seasoning of griddle surface.
- Replacement of fuses or resetting of circuit breakers, safety controls, or reset buttons.
- Replacement of broken or damaged glass components, quartz heating elements, and light bulbs.
- Labor charges for all removable and consumable parts in gas charbroilers and hotplates, including but not limited to burners, grates, and radiants.
- Any labor charges incurred by delays, waiting time, or operating restrictions that hinder a service technician's ability to perform service.
- Replacement of parts that fail or are damaged due to normal wear or labor for replacement of parts that can be replaced during a daily cleaning routine, such as but not limited to silicone belts, PTFE non-stick sheets, control labels, knobs, bulbs, fuses, quartz heating elements, baskets, racks, and grease drawers.
- Any economic loss of business or profits.
- Non-OEM parts. Use of non-OEM parts without Wells' approval will void the warranty.
- Units exceeding one [1] year from original installation date, or more than eighteen [18] months from original invoice date, whichever comes first.

ADDITIONAL WARRANTIES

- Specific/chain-specific equipment may have additional and/or extended warranties.

The foregoing warranty is in lieu of any and all other warranties expressed or implied and constitutes the entire warranty.

TABLE OF CONTENTS

Warranty	i
Warnings, General Information, and Installation	1-3
Wiring Diagrams	4-5
Daily Operation	6
Troubleshooting	6
Cleaning	7
Parts List	8-11
Exploded Views	12-16
Specifications	17
Installation Sheets	18-22
Wellslok Installation	23



NOTES

SAFETY SYMBOLS

These symbols are intended to alert the user to the presence of important operating and maintenance instructions in the manual accompanying the appliance.

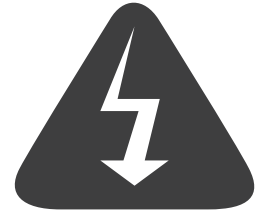

THOROUGHLY INSPECT YOUR UNIT ON ARRIVAL



This unit has been tested for proper operation before leaving our plant to ensure delivery of your unit in perfect condition. However, there are instances in which the unit may be damaged in transit. In the event you discover any type of damage to your product upon receipt, you must immediately contact the transportation company who delivered the item to you and initiate your claim with that company. If this procedure is not followed, it may affect the warranty status of the unit. If damage or loss is not apparent until after equipment is unpacked, a request for inspection of concealed damage must be made with carrier within 15 days. Please record the model number, serial number, voltage, and purchase date in the area below at the time of receipt..

Model Number _____

Serial Number _____

Voltage _____

Purchase Date _____

MAINTENANCE AND REPAIRS

Contact your local authorized service agent for service or required maintenance. Please have the information in the above fields ready when you call to ensure a faster service.

Using any part other than genuine Wells factory supplied parts relieves the manufacturer of all liability. Due to periodic changes in designs, methods, procedures, policies, and regulations, the specifications contained in this document are subject to change without notice. Wells reserves the right to change product specifications and design without notice. In regards to previously purchased equipment, such revisions do not entitle the buyer to corresponding changes, improvements, additions or replacements. While Wells Manufacturing exercises good faith efforts to provide information that is accurate, we are not responsible for errors or omissions in information provided or conclusions reached as a result of using the specifications. By using the information provided, the user assumes all risks in connection with such use. When performing maintenance, power to the unit should be unplugged or turned off.

PLEASE REFER TO THE WARRANTY PAGE FOR SPECIFIC WARRANTY INFORMATION.

AUTHORIZED SERVICE AGENT LISTING

Reference the listing provided with the unit or for an updated listing go to the website or call customer service to find an agent.

Business hours: 8:00 a.m. to 4:30 p.m. Central Standard Time

Telephone: (800) 264-7827

Email: customerservice@star-mfg.com

Website: www.wells-mfg.com



CAUTION



Never fill the unit with water or allow the control[s], motor, or element[s] to come in contact with liquid [other than as directed in the cleaning section of this manual]. Make certain while cleaning other units, as well as the floor and counters, that no overspray reaches this unit from above or from below the counter's surface.



Do not connect this appliance to power until all installation instructions are read, understood, and followed. Damage to the unit, the counter, or users may result if these instructions are not followed completely.



All servicing requiring access to non-insulated electrical components must be performed by a factory authorized technician. Do not open any access panel which requires the use of tools. Failure to follow this warning may result in severe electrical shock.



Exposed surfaces can be hot to the touch and may cause burns.



Avoid storing flammable or combustible materials in, on, or near the unit.



For warmers installed in plastic counter tops, the counter material must be protected from the heat of the warmer in order to prevent discoloration and/or deterioration. Wellsloks are not suitable for this purpose. The installer should contact the manufacturer or distributor of the countertop material for specific instructions.



Electrical installation other than as specified on the installation sheet will void the UL certification listing and may void the warranty. The ground lug of this appliance must be connected to a suitable building ground.



Always use a metal inset/food pan. Do not place food directly into the warmer.

INSTALLATION



YOU MUST CONSULT THE INSTALLATION SHEET FOR YOUR SPECIFIC MODEL FOR THE CORRECT INSTALLATION INFORMATION REGARDING CUTOUTS, CLEARANCES, AND OTHER IMPORTANT SPECIFICATIONS REGARDING SAFE AND RELIABLE OPERATION.

MDW100 installation sheet — 2M-Z20755

MDW200 installation sheet — 2M-Z20756

MDW300 installation sheet — 2M-Z20757

MDW400 installation sheet — 2M-Z20758

MDW500 installation sheet — 2M-Z20759

GENERAL SAFETY INFORMATION

This equipment is designed and sold for commercial use only, and is intended for use by personnel trained and experienced in its operation. This is not sold for consumer use in and around the home nor for use directly by the general public in food service locations. This appliance is intended to hold pre-heated food for human consumption. No other use is recommended or authorized by the manufacturer or its agents. Cleanliness of this appliance is essential to good sanitation. Read and follow all included cleaning instructions and schedules to ensure the safety of the food product.

Before using your new equipment, read and understand all the instructions and labels associated with the unit prior to putting it into operation. Exposed surfaces of this appliance can be hot to the touch and may cause burns. The presence of safety equipment and components cannot, in and of themselves, assure absolute safety of operation. Diligent, capable, well-trained operators and maintenance personnel, as well as proper programs of operation and maintenance, are essential to the safe and reliable operation of this unit.

Wells manufacturing is not responsible for injury, damage, loss or other claim that may occur to person or property from improper alteration, modification, addition, operation, maintenance or service, whether it be mechanical, electrical, or otherwise, which may occur from such improper alteration, modification, addition, operation, maintenance or service to this piece of equipment. Do not operate this appliance if the control panel is damaged. Call your authorized Wells service agent for service. The technical content of this manual is intended for use by qualified technical personnel only. Any procedure which requires the use of tools must be performed by a qualified technician.

GENERAL INSTALLATION INFORMATION

Installation procedures must be performed by an authorized technician with full knowledge of all applicable local codes. It is the responsibility of the installer to verify that the unit is installed in compliance with such codes and with the specifications and installation instructions specified for the unit. This appliance conforms to NSF standard 4 only if installed in accordance with the supplied installation instructions. Do not connect or energize this appliance until all installation instructions are read and followed. Damage to the appliance may result if these instructions are not followed. If operated improperly, damage to persons or property may result. Before using the unit for the first time, ensure to clean the unit properly. If the control panel is damaged, do not operate the unit and contact your authorized Wells service agent for assistance.



Refer to the installation sheet for your model for specific installation instructions related to cutout[s], wiring, etc.

ELECTRICAL CONNECTION



Electrical installation must only be performed by a certified electrical technician. Refer to the product's nameplate, wiring diagram, and installation sheet for specific electrical information. Voltage and phase must match the nameplate specifications for the unit. Wire gauge, insulation type, and temperature rating, as well as type, size, and construction of conduit, must meet or exceed applicable specifications of local codes and of the National Electrical Code.



Make certain to disconnect the unit from the power source before installing or removing any parts. This appliance is not jet stream approved. Do not direct water jet or steam jet at this appliance, or at any control panel or wiring. Do not splash or pour water on, in or over any controls, control panel or wiring.

WIRING DIAGRAMS

MDW100

208 V/240 V single phase

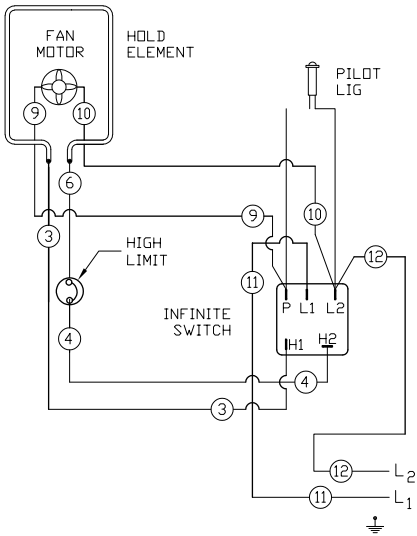

MDW200

208 V/240 V single phase

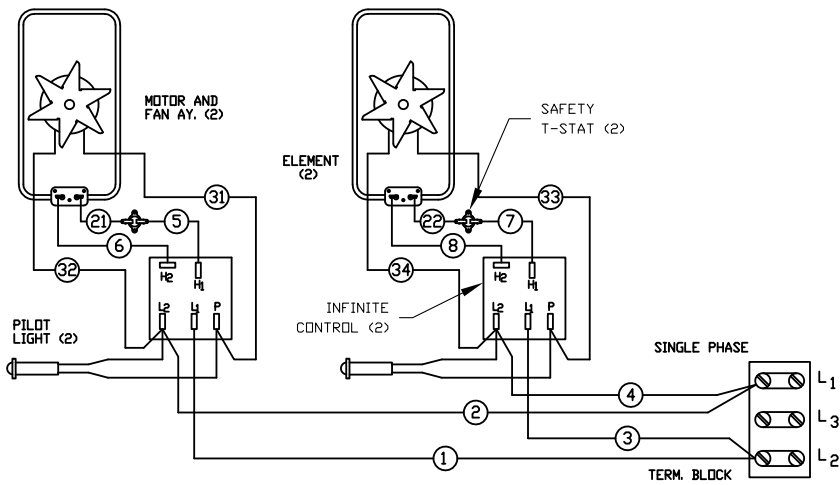

MDW300

208 V/240 V three phase

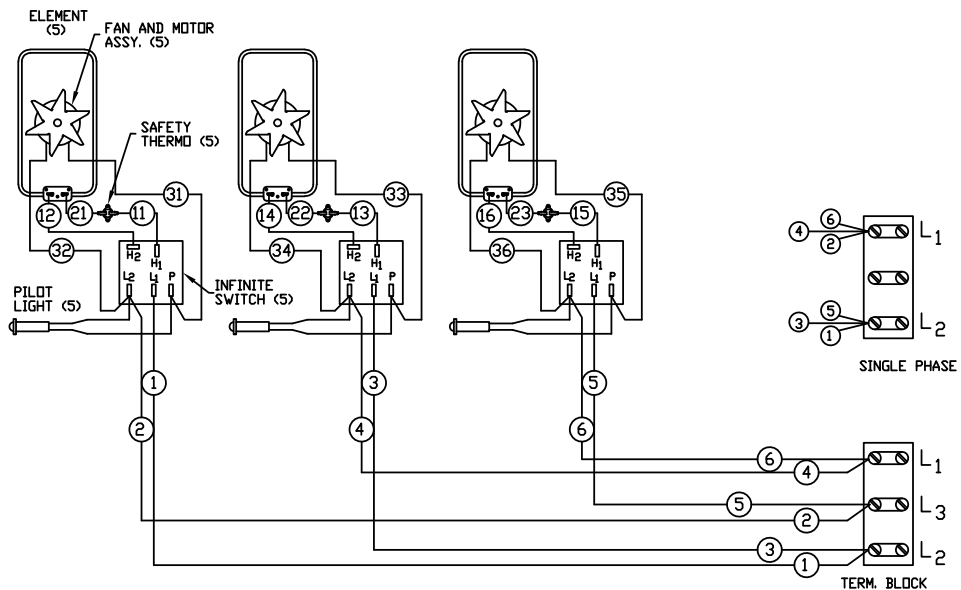

MDW400

208 V/240 V three phase

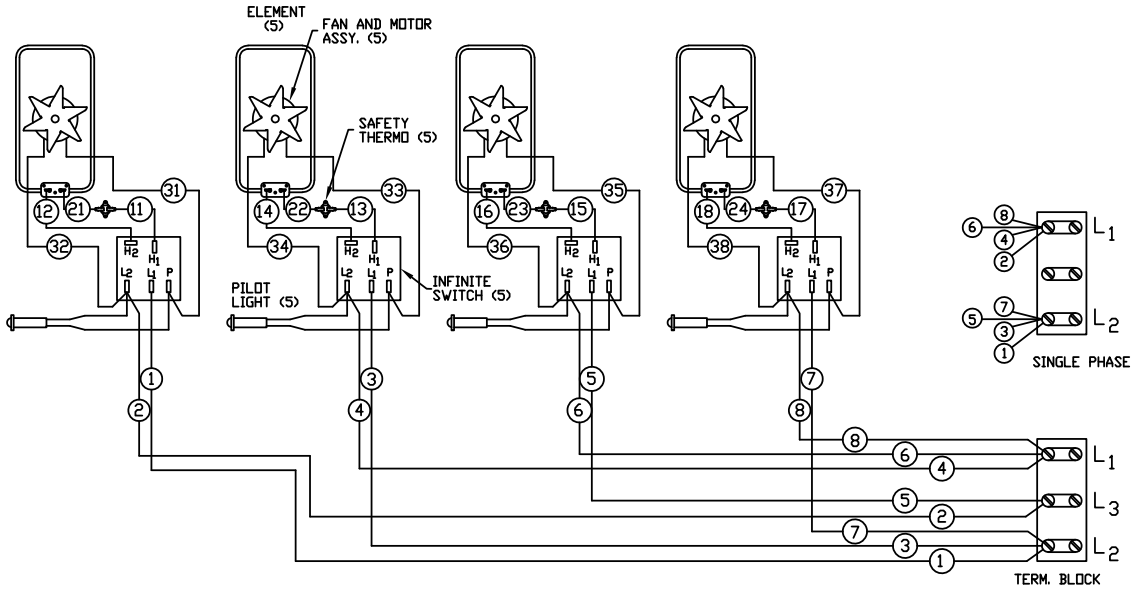

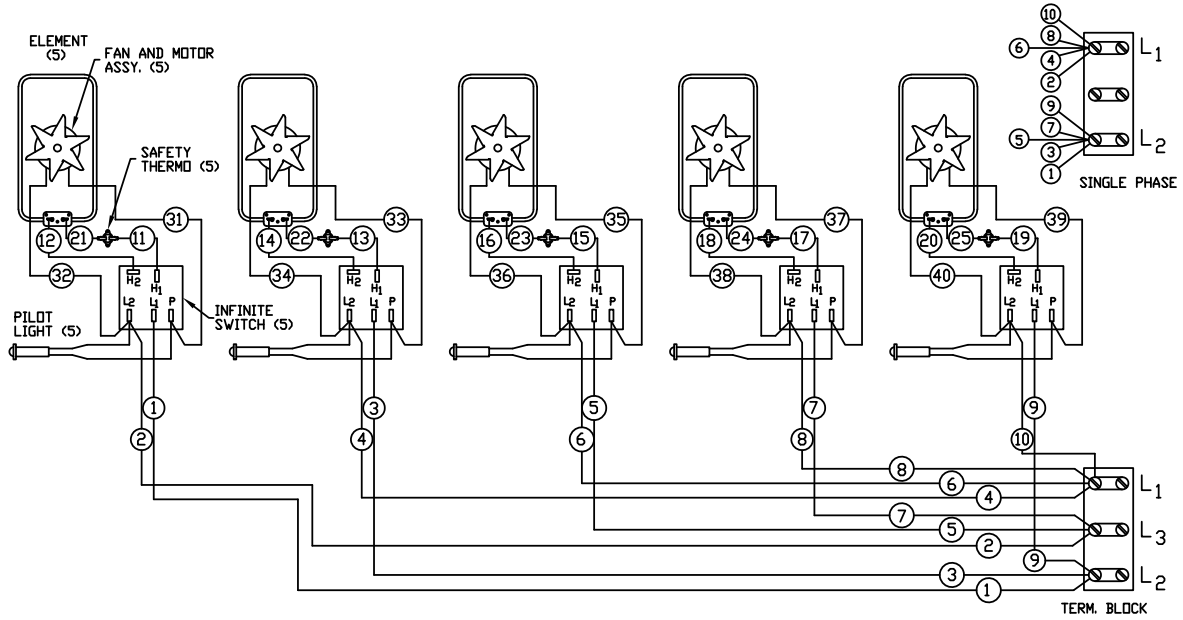

MDW500

208 V/240 V three phase



DAILY OPERATION

-  CERTAIN SURFACES ARE EXTREMELY HOT DURING OPERATION AND CARE SHOULD BE TAKEN WHILE USING THIS UNIT.
-  CARE SHOULD BE TAKEN WHEN REMOVING INSETS/PANS FROM THE UNIT. THE CONTROL SHOULD BE SET TO OFF BEFORE ATTEMPTING TO REMOVE ANY INSET/PAN.
-  THIS UNIT IS DESIGNED FOR DRY OPERATION ONLY. ANY DAMAGE CAUSED BY EXPOSING THE UNIT TO WATER WILL NOT BE COVERED BY WARRANTY.

PREHEATING THE WARMER

- i. Place desired pan[s], or inset[s] with appropriate adapter top, into warmer body. These units are designed to work with up to a 6-inch (152 mm) deep pan. Accessory insets [food pans] are available in 2.5 qt. (2.37 l), 4 qt. (3.79 l), 7 qt. (6.62 l), and 11 qt. (10.41 l) sizes with lids and adapter tops.
- ii. Turn temperature control to highest temperature setting.
- iii. Allow warmer to preheat for 15 minutes, then set the control for the desired temperature. The warmer should be covered at all times during preheat and operation.

OPERATION

- i. Once set to the desired temperature, place pans/insets into warmer. Never place product directly into the warmer.
- ii. Adjust temperature control as necessary to maintain proper product temperature.

TROUBLESHOOTING

SYMPTOMS	POSSIBLE CAUSES/TROUBLESHOOTING
There is no power to the warmer.	Is the circuit breaker off or tripped?
The warmer trips the circuit breaker when powered.	Is the flange to counter seal intact?
	Has water entered the unit or leaked on it or come into contact with it below the counter?
The warmer will not heat.	Is the temperature control set?
The warmer is slow to heat.	Does the pan you are using have mineral deposits, etc. that would inhibit heat transfer?
	Is the unit connected correctly and to the correct voltage?

CLEANING



BEFORE CLEANING, TURN THE CONTROL KNOB TO THE “OFF” POSITION AND ALLOW THE WARMER TO COOL COMPLETELY BEFORE PROCEEDING.

At each cleaning, inspect warmer flange-to-counter seal and inspect the warmer body for damage. If damage to the body exists, contact an authorized service agency before continuing use.

SUGGESTED CLEANING SUPPLIES

- i. Mild dish detergent and water
- ii. Surface sanitizer
- iii. Non-scratch scour pad [Scotch-Brite™ pad number 7445 recommended]
- iv. Clean cloth rag and/or sponge

DAILY CLEANING PROCEDURE

- i. Once the unit has completely cooled, remove any insets or pans to be washed separately. Remove the fan/element guard to be washed separately as well.
- ii. Use the non-scratch scouring pad to remove any deposits or food particles from the body of the unit. Gently, use the same type of pad on the element, making sure no cleaner or water is used on the element itself.
- iii. Wipe the body [excluding the element] down with a clean cloth or sponge and a mix of mild detergent and water. Rinse the cloth/sponge and then wipe down with clean water. Do not allow any excess liquid in the unit, just enough to moisten the sponge or cloth sufficiently for cleaning purposes.
- iv. Allow to dry and wipe with surface sanitizer. At this point, reinstall the clean fan/element guard and, when ready, any insets or pans that are to be used.

PARTS LIST

Items labeled “NP” are not pictured.

REF NO	PART NUMBER	MODEL	QTY	DESCRIPTION	PAGE NO
1	P2-Z18364	MDW100	1	fan guard/baffle	12
		MDW200	2		13
		MDW300	3		14
		MDW400	4		15
		MDW500	5		16
2	2N-Z20665UL	MDW100	1	heating element	12
		MDW200	2		13
		MDW300	3		14
		MDW400	4		15
		MDW500	5		16
3	2I-Z20715	MDW100	1	heating element mounting gasket	12
		MDW200	2		13
		MDW300	3		14
		MDW400	4		15
		MDW500	5		16
4	2C-Z21422	MDW100	7	#8-32 x 0.5 in. (13 mm) screw	12
		MDW200	14		13
		MDW300	21		14
		MDW400	28		15
		MDW500	35		16
5	P2-WL0809	MDW100	1	motor and fan assembly [includes number 4 and 6]	12
		MDW200	2		13
		MDW300	3		14
		MDW400	4		15
		MDW500	5		16
6	2I-Z20767	MDW100	1	motor assembly gasket	12
		MDW200	2		13
		MDW300	3		14
		MDW400	4		15
		MDW500	5		16
7	P2-WL0806	MDW100	1	body [includes parts 8, 9, and 10 for the specified unit]	12
	P2-WL0816	MDW200			13
	P2-WL0820	MDW300			14
	P2-WL0805	MDW400			15
	P2-WL0826	MDW500			16

REF NO	PART NUMBER	MODEL	QTY	DESCRIPTION	PAGE NO
8	P2-Z21428	MDW100	2	side panel	12
	P2-303359	MDW200			13
		MDW300			14
		MDW400			15
		MDW500			16
9	P2-WL0803	MDW100	2	front or back panel	12
	P2-33909	MDW200	1	rear panel	13
	P2-48193	MDW300			14
	P2-48192	MDW400			15
	P2-48191	MDW500			16
10	P2-Z15948	MDW200	1	front panel	13
	P2-303357	MDW300			14
	P2-Z22471	MDW400			15
	P2-Z22473	MDW500			16
11	2T-Z20720	MDW100	1	high limit thermostat	12
		MDW200	2		13
		MDW300	3		14
		MDW400	4		15
		MDW500	5		16
12	P2-Z21786	MDW100	1	bracket for high limit thermostat	12
		MDW200	2		13
		MDW300	3		14
		MDW400	4		15
		MDW500	5		16
13	2C-Z2594	MDW100	2	6-32 keps nut	12
		MDW200	4		13
		MDW300	6		14
		MDW400	8		15
		MDW500	10		16
14	P2-Z20696	MDW100	1	bottom insulation shield	12
		MDW200	2		13
		MDW300	3		14
		MDW400	4		15
		MDW500	5		16
15	2C-08-07-0207	MDW100	4	#10-24 hex nut	12
		MDW200	8		13
		MDW300	12		15
		MDW400	16		15
		MDW500	20		16

REF NO	PART NUMBER	MODEL	QTY	DESCRIPTION	PAGE NO
16	2C-6349	MDW100	16	#8 screw	12 14
		MDW200	32		
		MDW300	40		
		MDW400	72		
		MDW500	82		
17	2K-Z2895	MDW100	1	strain relief bushing	14 15
		MDW200	2		
		MDW300	3		
		MDW400	4		
		MDW500	5		
18	P2-37935	MDW200	2	fiber washer	13 14 15 16
		MDW300			
	P2-Z22663	MDW400			
	MDW500				
19	P2-Z20699	MDW100	1	bottom insulation	12 13 14 15 16
	P2-Z22084	MDW200	1		
	P2-Z22087	MDW300	1		
	P2-Z22084	MDW400	2		
	P2-Z22084	MDW500	1		
	P2-Z22087		1		
20	P2-Z21791	MDW100	1	bottom panel	12 13 14 15 16
	P2-Z21944	MDW200	1		
	P2-Z21945	MDW300	1		
	P2-Z21944	MDW400	2		
	P2-Z21944	MDW500	1		
	P2-Z21945		1		
21	P2-Z18370	MDW100	1	motor guard	12 13 14 15 16
		MDW200	2		
		MDW300	3		
		MDW400	4		
		MDW500	5		
22	P2-37746	MDW400	1	bottom cover brace	15 16
		MDW500			
23	2R-4373	MDW100	1	control knob	12
		MDW200	2		
		MDW300	3		
		MDW400	4		
		MDW500	5		
24	2M-45634	ALL	1	NSF label	12
25	2K-34136X	ALL	1	90° flex conduit fitting	12
25a	2K-Z22528	MDW400	2		12
		MDW500			12

REF NO	PART NUMBER	MODEL	QTY	DESCRIPTION	PAGE NO
26	2M-49919	MDW200	1	Wells logo	12
		MDW300			
		MDW400			
		MDW500			
27	I7-Z12221	MDW100	1	control face plate	12
	P2-Z12288	MDW200			
	P2-Z12592	MDW300			
	P2-Z12591	MDW400			
	P2-Z12590	MDW500			
28	P2-40843	MDW100	1	switch and light mounting bracket	12
		MDW200	2		
	P2-37809	MDW300	1		
		MDW400			
		MDW500			
29	2E-37465	MDW200	1	terminal block	12
		MDW300			
		MDW400			
		MDW500			
30	2J-30385	MDW100	1	signal light	12
		MDW200	2		
		MDW300	3		
		MDW400	4		
		MDW500	5		
31	2E-30562	MDW100	1	infinite switch	12
		MDW200	2		
		MDW300	3		
		MDW400	4		
		MDW500	5		
32	P2-31033	MDW100	1	control panel body	12
	E7-49046	MDW200			
	P2-46685	MDW300			
	P2-Z22664	MDW400			
		MDW500			
33	P2-Z18451	MDW100	1	nameplate	12
	P2-Z22072	MDW200			
	P2-Z22085	MDW300			
	P2-Z22118	MDW400			
	P2-Z22119	MDW500			
34	I7-34134	MDW100	1	2' flex conduit	NP
	P2-34135	MDW200	1		
		MDW300			
	IM-Z22529	MDW400	1		
		MDW500			

EXPLODED VIEW

CONTROL PANELS and MDW100

CONTROL PANEL

MDW300 [same outer box with alternate mounting and face plate as well additional switches, etc. for MDW400 and MDW500]

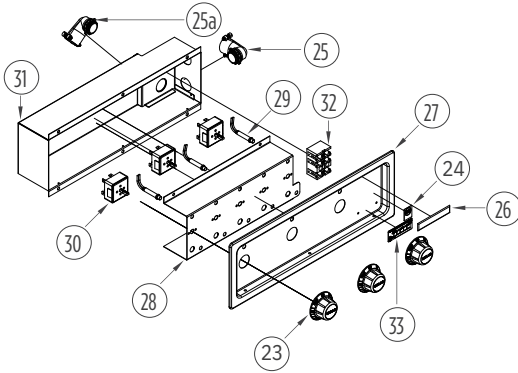

CONTROL PANEL

MDW200

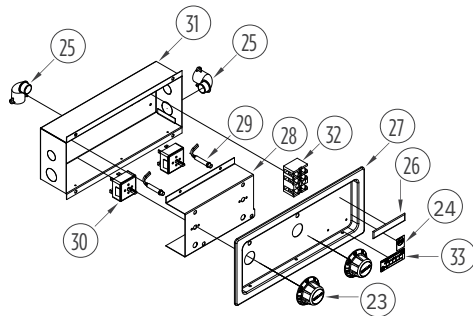

CONTROL PANEL

MDW100

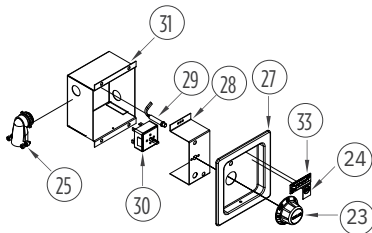

MDW100

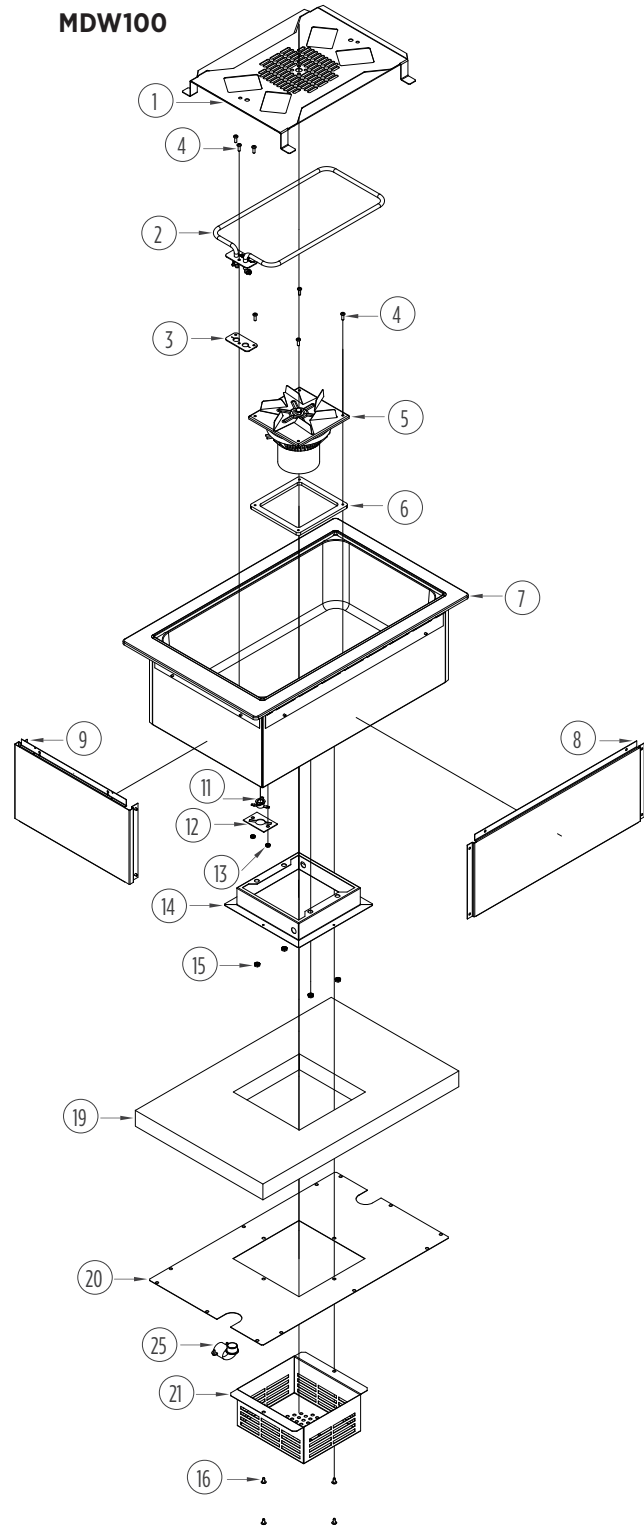

EXPLODED VIEW
MDW200

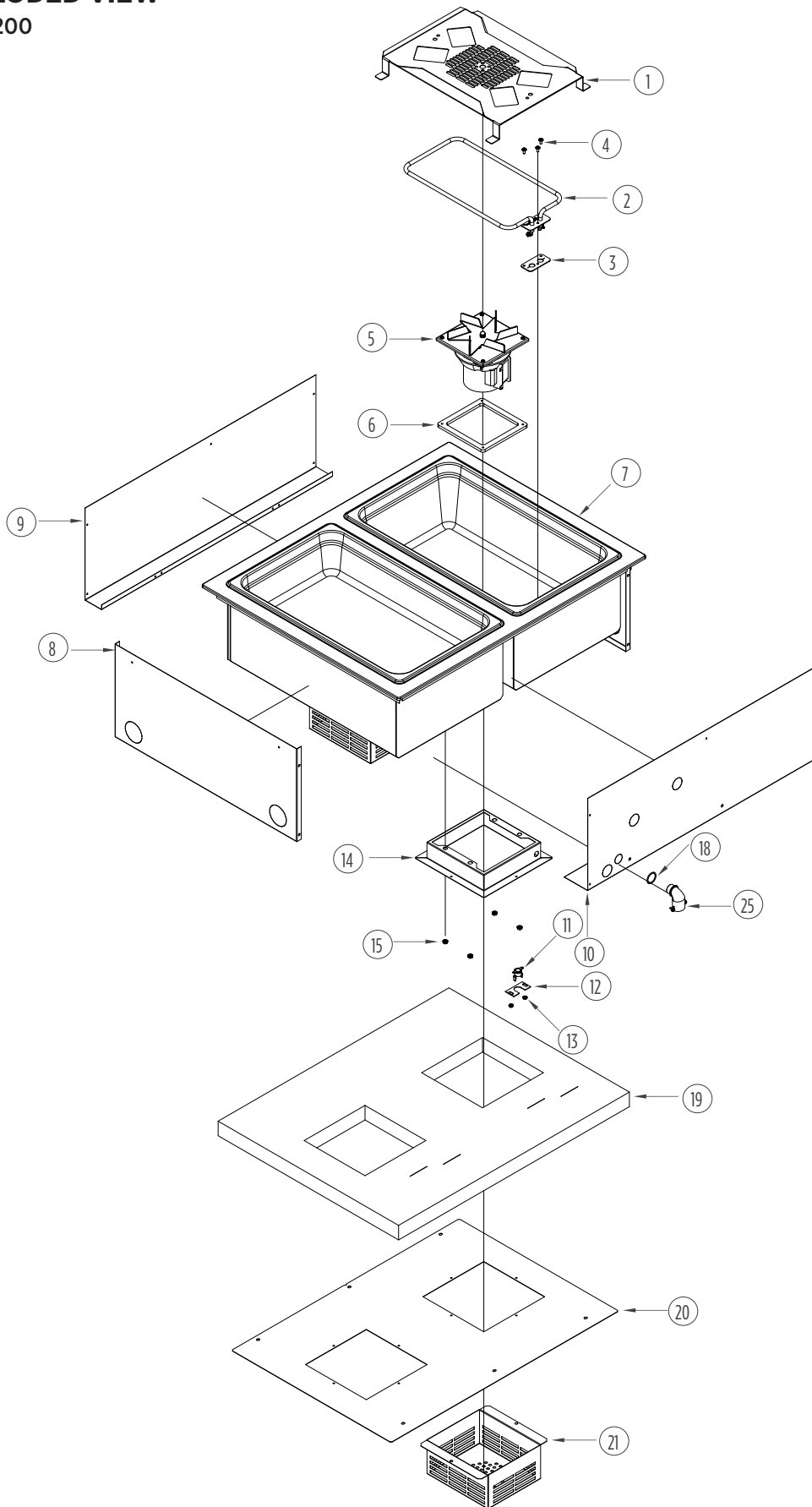

EXPLODED VIEW
MDW300

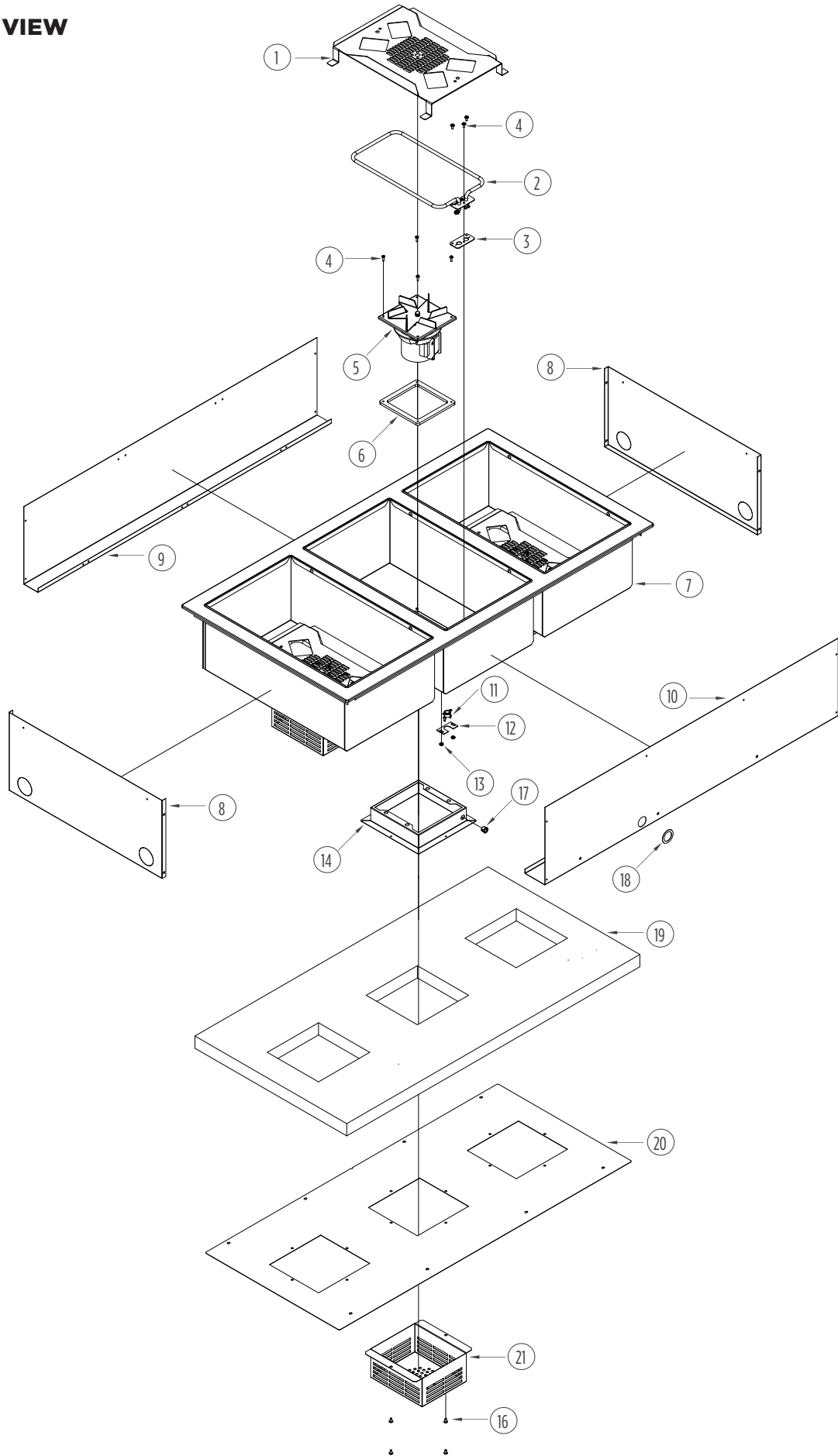

EXPLODED VIEW
MDW400

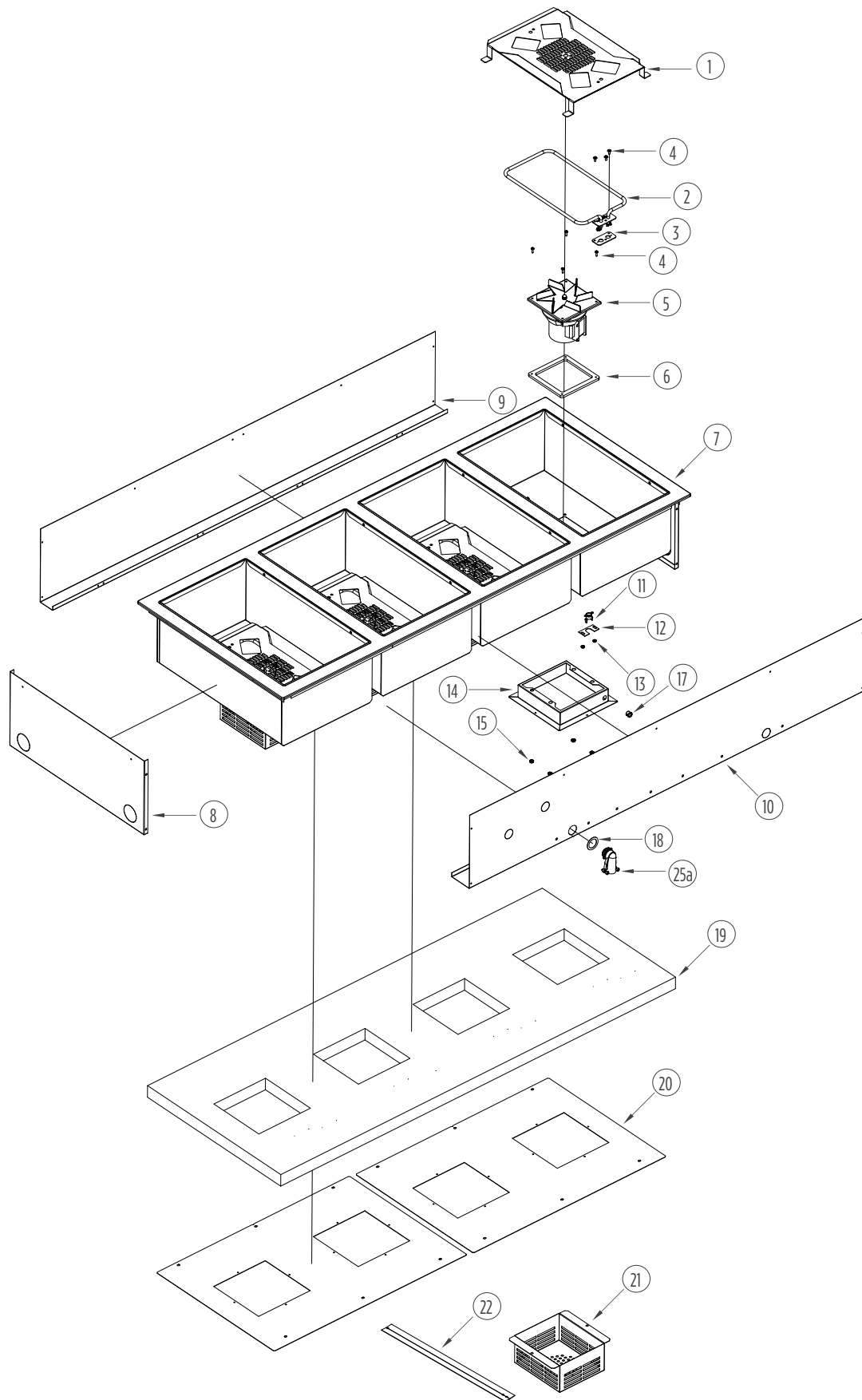

EXPLODED VIEW
MDW500

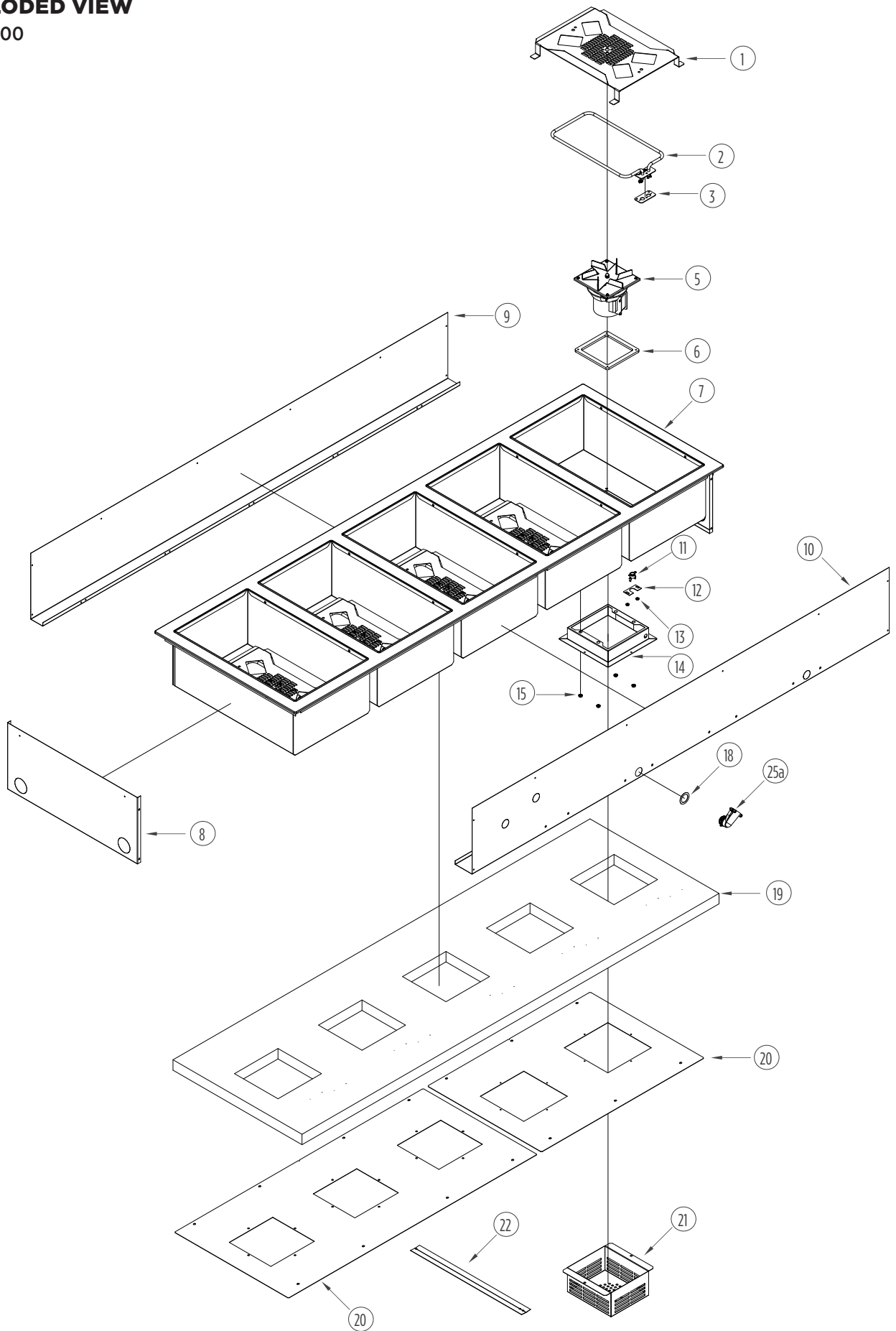

SPECIFICATIONS

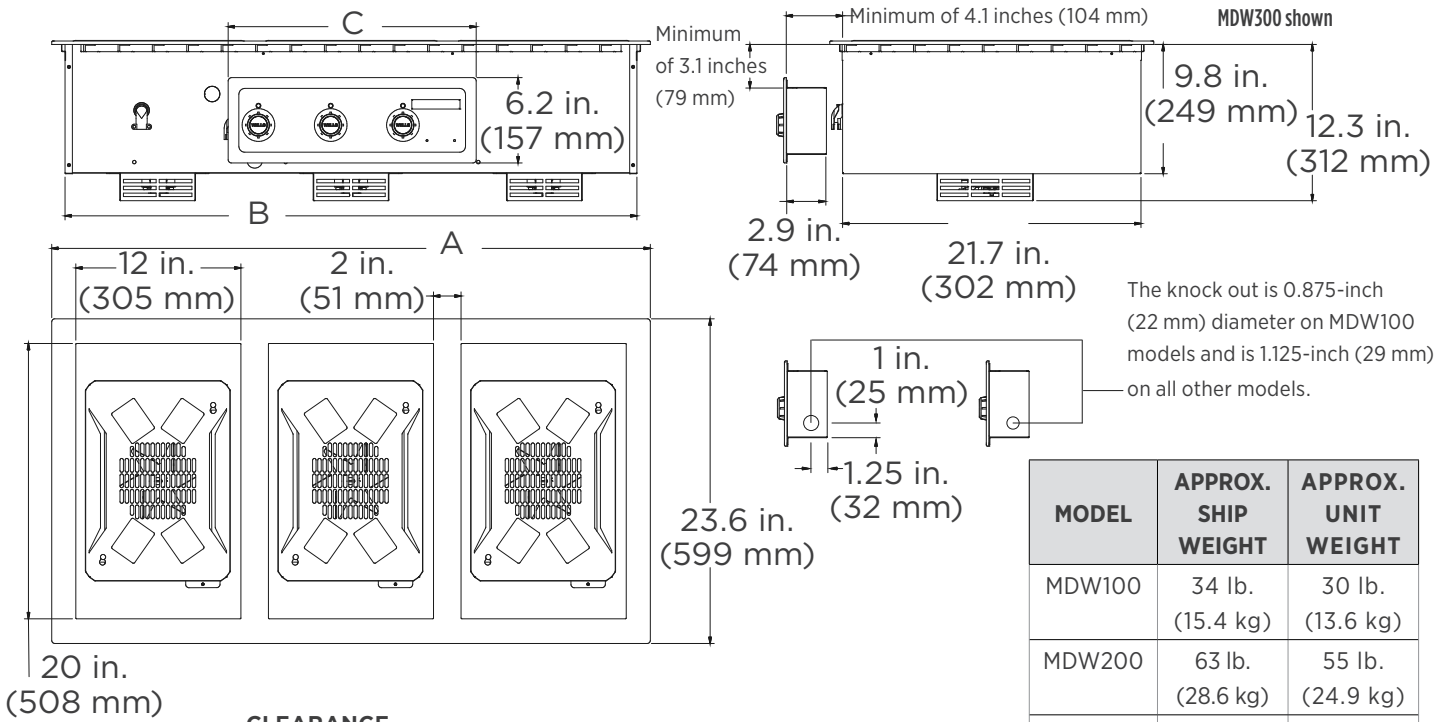

CLEARANCE

Do not install closer than six [6] inches (152 mm) to front wall, one [1] inch (25 mm) to back and side walls, and 6.75 inches (171 mm) to a surface below the unit. If storage is to be used underneath, it is recommended that a baffle be placed 8.5 inches (216 mm) below the unit to avoid contact with elevated temperatures.

MODEL	APPROX. SHIP WEIGHT	APPROX. UNIT WEIGHT
MDW100	34 lb. (15.4 kg)	30 lb. (13.6 kg)
MDW200	63 lb. (28.6 kg)	55 lb. (24.9 kg)
MDW300	160 lb. (72.6 kg)	80 lb. (36.3 kg)
MDW400	185 lb. (83.9 kg)	105 lb. (47.6 kg)
MDW500	210 lb. (95.3 kg)	130 lb. (59 kg)

MODEL	TOP WIDTH [A]	BOTTOM WIDTH [B]	CONTROL WIDTH [C]	DEPTH	HEIGHT BELOW SURFACE	VOLTS, PHASE	AMPS			TOTAL kW
							L1	L2	L3	
MDW100	14.8 in. (376 mm)	13.2 in. (335 mm)	5.9 in. (149 mm)	20 in. (508 mm)	11.9 in. (302 mm)	208, 1Φ 240, 1Φ	2.9			0.61
							3.3			0.8
MDW200	29.5 in. (749 mm)	27.6 in. (701 mm)	14.1 in. (359 mm)	20 in. (508 mm)	11.9 in. (302 mm)	208, 1Φ 240, 1Φ	5.9			1.22
							6.7			1.6
MDW300	43.5 in. (1.1 m)	41.6 in. (1.06 m)	18 in. (457 mm)	20 in. (508 mm)	11.9 in. (302 mm)	208, 3Φ 240, 3Φ	5.1	5.1	5.1	1.83
							5.8	5.8	5.8	2.4
MDW400	57.5 in. (1.46 m)	55.6 in. (1.41 m)	18 in. (457 mm)	20 in. (508 mm)	11.9 in. (302 mm)	208, 3Φ 240, 3Φ	5.1	7.6	7.6	2.44
							5.8	8.7	8.7	3.2
MDW500	71.5 in. (1.82 m)	69.6 in. (1.77 m)	18 in. (457 mm)	20 in. (508 mm)	11.9 in. (302 mm)	208, 3Φ 240, 3Φ	7.6	7.6	10.1	3.05
							8.7	8.7	11.5	4

SAFETY SANITATION AGENCY LISTING INFORMATION

The nameplate of your unit will show the specific agency listing information.





MDW100 Modular Dry Well

Installation Instructions

INSTALLATION REQUIREMENTS

Do not install closer than 4.125 inches (105 mm) to front wall, one [1] inch (25 mm) to back and side walls, and 6.75 inches (171 mm) to a surface below the unit. If storage is to be used underneath, it is recommended that a baffle be placed 8.5 inches (216 mm) below the unit to avoid contact with elevated temperatures. The unit will need to be accessible from the bottom after installation is complete.

A proper electrical connection based on the units electrical specifications will be necessary for installation. *This must be wired and connected by a licensed electrician. Electrical installation will need to pass local electrical codes.*

FABRICATION

- i. Lay out cutout dimensions on countertop and front apron.
- ii. Lay out control panel mounting holes in counter apron using the provided dimensions. The mounting holes should be 0.144 inch (3.7 mm) in diameter [drill size 27].
- iii. Cut out the holes. On many countertops, reinforcement may be needed to stiffen the countertop.

INSTALLATION INSTRUCTIONS

Do not disconnect the control box from the modular unit.

- i. Remove the knobs and faceplate from the control box. Pass the control box through the countertop cutout, and then through the apron cutout. This will require the box to be rotated so the mounting tabs clear the hole. Next, lower and position the modular section into countertop cutout.
- ii. Before final seating of modular section to countertop, apply a bead of silicone sealant to the underside of the grey gasket material supplied on the mounting flange. From underneath, insert screwdriver into the slots in the Wellslok frame and twist clockwise to move the ears outward as required to secure the flange tightly to countertop.¹
- iii. Mount the control box to apron cutout using #10 sheet metal [or wood] screws to the facing side where the holes were drilled.
- iv. Run wiring through the conduit knockout to the terminal block, making connection as shown in the unit's wiring diagram to the correct power source.
- v. Mount the front panel onto the control box using the provided hardware and place the knob on. At this point, you should be able to power on the unit and check for proper operation.

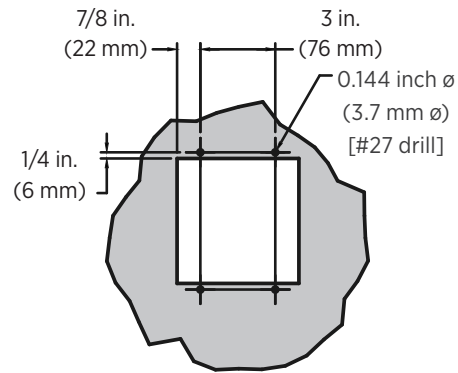
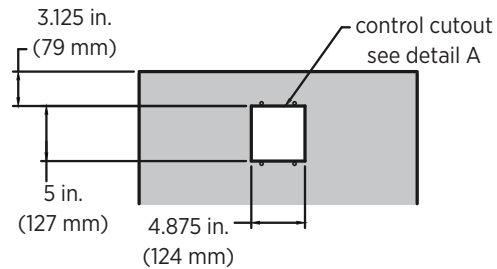
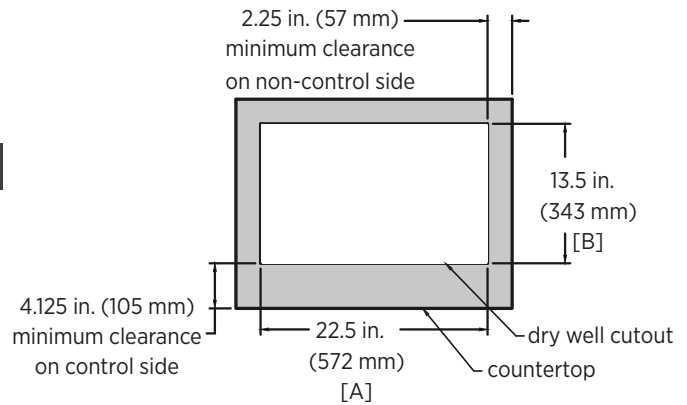

The unit's overall depth is 12.125 inches (308 mm) will sit approximately 11.75 inches (298 mm) below the counter surface depending on counter thickness.

When installing multiple units, each unit will need a space of at least 2.125 inches (54 mm) between the cutouts on the long dimension sides [A] and at least 3.625 inches (92 mm) between cutouts on the short dimension side [B].

MODEL	TOTAL kW	VOLTS, PHASE	AMPS
MDW100	0.61	208, 1Φ	2.9
	0.8	240, 1Φ	3.3

The supply wire will need to be the correct gauge as described by the National Electrical Code and be rated to at least 167°F (75°C).

¹ Wellslok adapter kit will use hex screws to tighten and allow installation on countertops up to 1.5 inches (38 mm) thick.



WELLS BLOOMFIELD, LLC • www.wellsbloomfield.com
 265 Hobson Street • Smithville, Tennessee 37166
 Telephone (800) 264-7827

Printed in the U.S.A. • 2M-Z20755 • Rev B • 05.2018
 The owner is responsible for proper installation as described above. Please refer to the owner's manual for information regarding installation or use.



MDW200 Modular Dry Well

Installation Instructions

INSTALLATION REQUIREMENTS

Do not install closer than 4.125 inches (105 mm) to front wall, one [1] inch (25 mm) to back and side walls, and 6.75 inches (171 mm) to a surface below the unit. If storage is to be used underneath, it is recommended that a baffle be placed 8.5 inches (216 mm) below the unit to avoid contact with elevated temperatures. The unit will need to be accessible from the bottom after installation is complete.

A proper electrical connection based on the units electrical specifications will be necessary for installation. *This must be wired and connected by a licensed electrician. Electrical installation will need to pass local electrical codes.*

FABRICATION

- i. Lay out cutout dimensions on countertop and front apron.
- ii. Lay out control panel mounting holes in counter apron using the control box as a template. The mounting holes should be 0.144 inch (3.7 mm) in diameter [drill size 27].
- iii. Cut out the holes. On many countertops, reinforcement may be needed to stiffen the countertop.

INSTALLATION INSTRUCTIONS

Do not disconnect the control box from the modular unit.

- i. Remove the knobs and faceplate from the control box. Pass the control box through the countertop cutout, and then through the apron cutout. This will require the box to be rotated so the mounting tabs clear the hole. Next, lower and position the modular section into countertop cutout.
- ii. Before final seating of modular section to countertop, apply a bead of silicone sealant to the underside of the grey gasket material supplied on the mounting flange. From underneath, insert screwdriver into the slots in the Wellslok frame and twist clockwise to move the ears outward as required to secure the flange tightly to countertop.¹
- iii. Mount the control box to apron cutout using #10 sheet metal [or wood] screws to the facing side where the holes were drilled.
- iv. Run wiring through the conduit knockout to the terminal block, making connection as shown in the unit's wiring diagram to the correct power source.
- v. Mount the front panel onto the control box using the provided hardware and place the knobs/covers on. At this point, you should be able to power on the unit and check for proper operation.

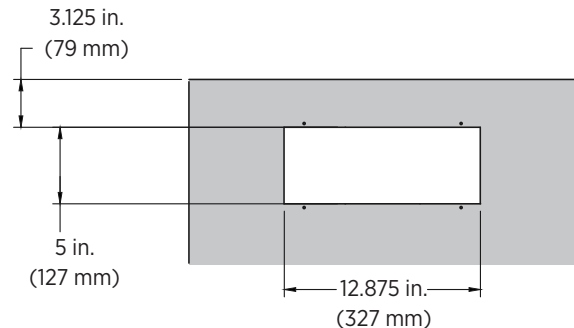
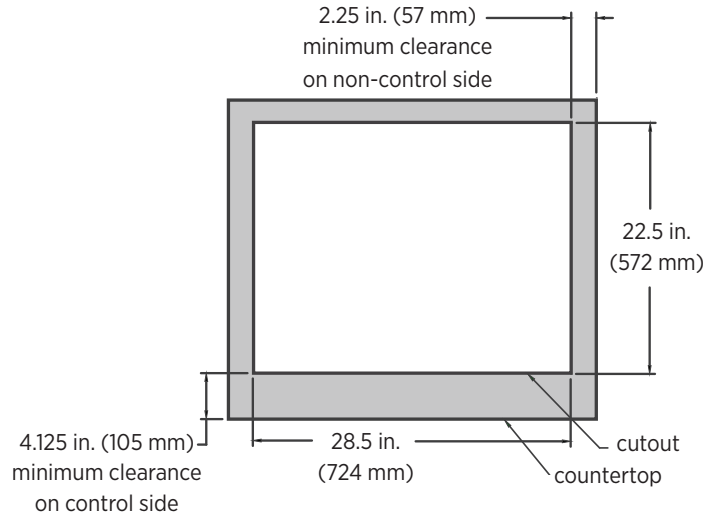

The unit's overall depth is 12.125 inches (308 mm) and will sit approximately 11.75 inches (298 mm) below the counter surface depending on counter thickness.

MODEL	TOTAL kW	VOLTS, PHASE	AMPS
MDW200	1.22	208, 1Φ	5.9
	1.6	240, 1Φ	6.7
MDW200R	1.9	208, 1Φ	9.1
	2.5	240, 1Φ	10.4

The supply wire will need to be the correct gauge as described by the National Electrical Code and be rated to at least 167°F (75°C).

¹ Wellslok adapter kits [2 required] will use hex screws to tighten and allow installation on countertops up to 1.5 inches (38 mm) thick.



WELLS BLOOMFIELD, LLC • www.wellsbloomfield.com
 265 Hobson Street • Smithville, Tennessee 37166
 Telephone (800) 264-7827

Printed in the U.S.A. • 2M-Z20756 • Rev A • 03.2017
 The owner is responsible for proper installation as described above. Please refer to the owner's manual for information regarding installation or use.



MDW300 Modular Dry Well

Installation Instructions

INSTALLATION REQUIREMENTS

Do not install closer than 4.125 inches (105 mm) to front wall, one [1] inch (25 mm) to back and side walls, and 6.75 inches (171 mm) to a surface below the unit. If storage is to be used underneath, it is recommended that a baffle be placed 8.5 inches (216 mm) below the unit to avoid contact with elevated temperatures. The unit will need to be accessible from the bottom after installation is complete.

A proper electrical connection based on the units electrical specifications will be necessary for installation. *This must be wired and connected by a licensed electrician. Electrical installation will need to pass local electrical codes.*

FABRICATION

- i. Lay out cutout dimensions on countertop and front apron.
- ii. Lay out control panel mounting holes in counter apron using the control box as a template. The mounting holes should be 0.144 inch (3.7 mm) in diameter [drill size 27].
- iii. Cut out the holes. On many countertops, reinforcement may be needed to stiffen the countertop.

INSTALLATION INSTRUCTIONS

Do not disconnect the control box from the modular unit.

- i. Remove the knobs and faceplate from the control box. Pass the control box through the countertop cutout, and then through the apron cutout. This will require the box to be rotated so the mounting tabs clear the hole. Next, lower and position the modular section into countertop cutout.
- ii. Before final seating of modular section to countertop, apply a bead of silicone sealant to the underside of the grey gasket material supplied on the mounting flange. From underneath, insert screwdriver into the slots in the Wellslok frame and twist clockwise to move the ears outward as required to secure the flange tightly to countertop.
- iii. Mount the control box to apron cutout using #10 sheet metal [or wood] screws to the facing side where the holes were drilled.
- iv. Run wiring through the conduit knockout to the terminal block, making connection as shown in the unit's wiring diagram to the correct power source.
- v. Mount the front panel onto the control box using the provided hardware and place the knobs/covers on. At this point, you should be able to power on the unit and check for proper operation.

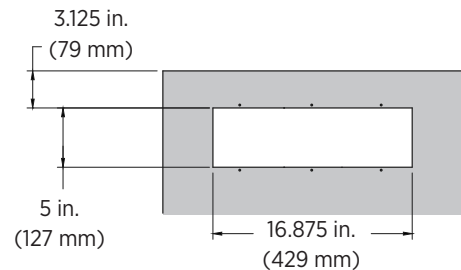
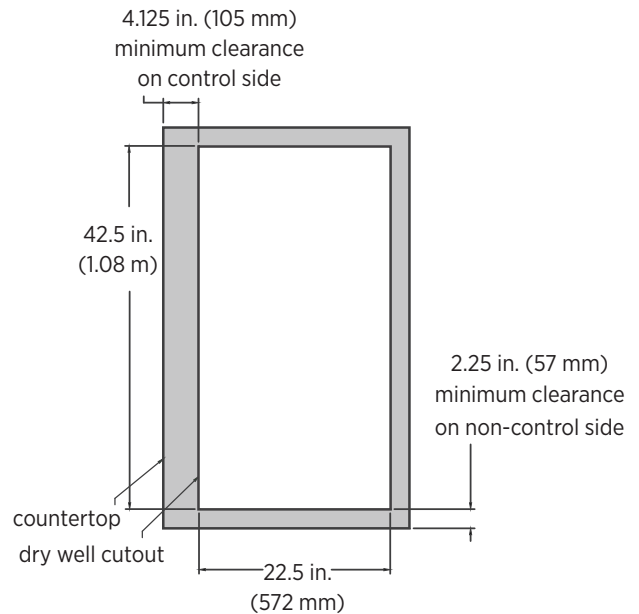

The unit's overall depth is 12.125 inches (308 mm) will sit approximately 11.75 inches (298 mm) below the counter surface depending on counter thickness.

MODEL	TOTAL kW	VOLTS, PHASE	AMPS		
			L1	L2	L3
MDW300	1.83	208, 3Φ	5.1	5.1	5.1
	2.4	240, 3Φ	5.8	5.8	5.8
MDW300R	2.85	208, 3Φ	7.9	7.9	7.9
	3.75	240, 3Φ	9	9	9

The supply wire will need to be the correct gauge as described by the National Electrical Code and be rated to at least 167°F (75°C).

¹ Wellslok adapter kits [3 required] will use hex screws to tighten and allow installation on countertops up to 1.5 inches (38 mm) thick.



WELLS BLOOMFIELD, LLC • www.wellsbloomfield.com
 265 Hobson Street • Smithville, Tennessee 37166
 Telephone (800) 264-7827

Printed in the U.S.A. • 2M-Z20757 • Rev A • 03.2017
 The owner is responsible for proper installation as described above. Please refer to the owner's manual for information regarding installation or use.



MDW400 Modular Dry Well

Installation Instructions

INSTALLATION REQUIREMENTS

Do not install closer than 4.125 inches (105 mm) to front wall, one [1] inch (25 mm) to back and side walls, and 6.75 inches (171 mm) to a surface below the unit. If storage is to be used underneath, it is recommended that a baffle be placed 8.5 inches (216 mm) below the unit to avoid contact with elevated temperatures. The unit will need to be accessible from the bottom after installation is complete.

A proper electrical connection based on the units electrical specifications will be necessary for installation. *This must be wired and connected by a licensed electrician. Electrical installation will need to pass local electrical codes.*

FABRICATION

- i. Lay out cutout dimensions on countertop and front apron.
- ii. Lay out control panel mounting holes in counter apron using the control box as a template. The mounting holes should be 0.144 inch (3.7 mm) in diameter [drill size 27].
- iii. Cut out the holes. On many countertops, reinforcement may be needed to stiffen the countertop.

INSTALLATION INSTRUCTIONS

Do not disconnect the control box from the modular unit.

- i. Remove the knobs and faceplate from the control box. Pass the control box through the countertop cutout, and then through the apron cutout. This will require the box to be rotated so the mounting tabs clear the hole. Next, lower and position the modular section into countertop cutout.
- ii. Before final seating of modular section to countertop, apply a bead of silicone sealant to the underside of the grey gasket material supplied on the mounting flange. From underneath, insert screwdriver into the slots in the Wellslok frame and twist clockwise to move the ears outward as required to secure the flange tightly to countertop.
- iii. Mount the control box to apron cutout using #10 sheet metal [or wood] screws to the facing side where the holes were drilled.
- iv. Run wiring through the conduit knockout to the terminal block, making connection as shown in the unit's wiring diagram to the correct power source.
- v. Mount the front panel onto the control box using the provided hardware and place the knobs/covers on. At this point, you should be able to power on the unit and check for proper operation.

4.125 in. (105 mm)
minimum clearance
on control side

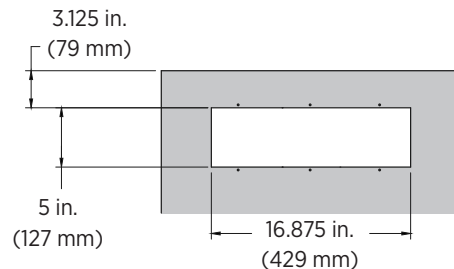
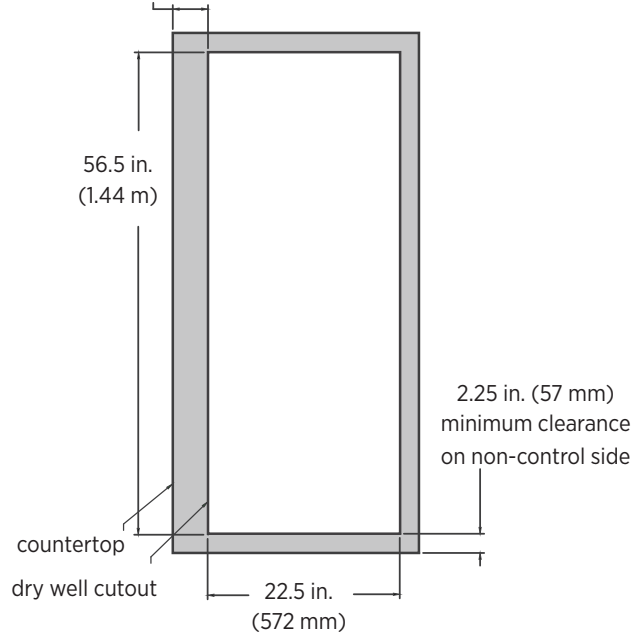

The unit's overall depth is 12.125 inches (308 mm) will sit approximately 11.75 inches (298 mm) below the counter surface depending on counter thickness.

MODEL	TOTAL kW	VOLTS, PHASE	AMPS		
			L1	L2	L3
MDW400	2.44	208, 3Φ	5.1	7.6	7.6
	3.2	240, 3Φ	5.8	8.7	8.7
MDW400R	3.8	208, 3Φ	7.9	11.9	11.9
	5	240, 3Φ	9.0	13.5	13.5

The supply wire will need to be the correct gauge as described by the National Electrical Code and be rated to at least 167°F (75°C).

¹ Wellslok adapter kits [3 required] will use hex screws to tighten and allow installation on countertops up to 1.5 inches (38 mm) thick.



WELLS BLOOMFIELD, LLC • www.wellsbloomfield.com
265 Hobson Street • Smithville, Tennessee 37166
Telephone (800) 264-7827

Printed in the U.S.A. • 2M-Z20758 • Rev A • 03.2017
The owner is responsible for proper installation as described above. Please refer to the owner's manual for information regarding installation or use.



MDW500 Modular Dry Well

Installation Instructions

INSTALLATION REQUIREMENTS

Do not install closer than 4.125 inches (105 mm) to front wall, one [1] inch (25 mm) to back and side walls, and 6.75 inches (171 mm) to a surface below the unit. If storage is to be used underneath, it is recommended that a baffle be placed 8.5 inches (216 mm) below the unit to avoid contact with elevated temperatures. The unit will need to be accessible from the bottom after installation is complete.

A proper electrical connection based on the units electrical specifications will be necessary for installation. *This must be wired and connected by a licensed electrician. Electrical installation will need to pass local electrical codes.*

FABRICATION

- i. Lay out cutout dimensions on countertop and front apron.
- ii. Lay out control panel mounting holes in counter apron using the control box as a template. The mounting holes should be 0.144 inch (3.7 mm) in diameter [drill size 27].
- iii. Cut out the holes. On many countertops, reinforcement may be needed to stiffen the countertop.

INSTALLATION INSTRUCTIONS

Do not disconnect the control box from the modular unit.

- i. Remove the knobs and faceplate from the control box. Pass the control box through the countertop cutout, and then through the apron cutout. This will require the box to be rotated so the mounting tabs clear the hole. Next, lower and position the modular section into countertop cutout.
- ii. Before final seating of modular section to countertop, apply a bead of silicone sealant to the underside of the grey gasket material supplied on the mounting flange. From underneath, insert screwdriver into the slots in the Wellslok frame and twist clockwise to move the ears outward as required to secure the flange tightly to countertop.
- iii. Mount the control box to apron cutout using #10 sheet metal [or wood] screws to the facing side where the holes were drilled.
- iv. Run wiring through the conduit knockout to the terminal block, making connection as shown in the unit's wiring diagram to the correct power source.
- v. Mount the front panel onto the control box using the provided hardware and place the knobs/covers on. At this point, you should be able to power on the unit and check for proper operation.

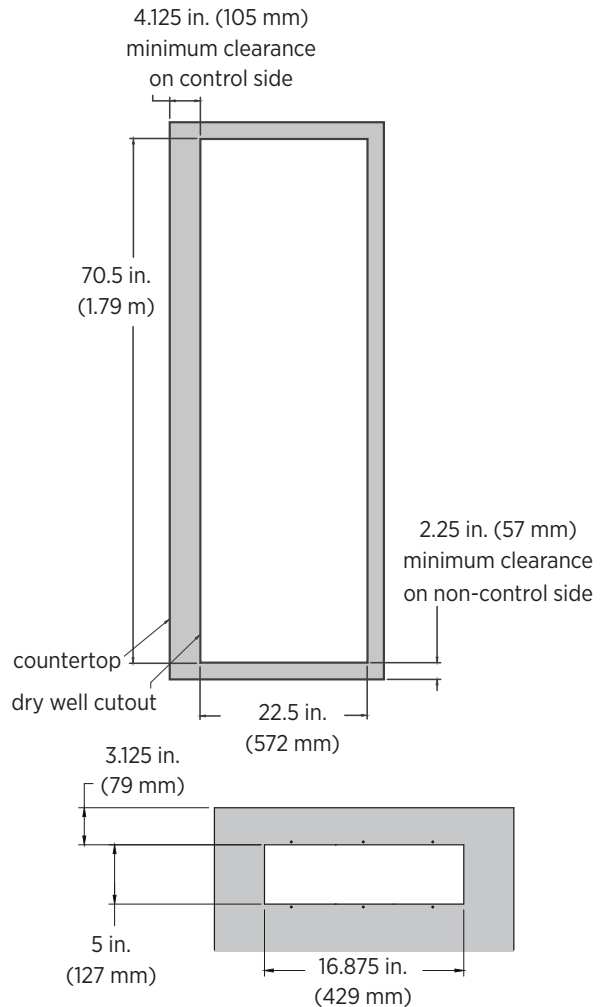

The unit's overall depth is 12.125 inches (308 mm) will sit approximately 11.75 inches (298 mm) below the counter surface depending on counter thickness.

MODEL	TOTAL kW	VOLTS, PHASE	AMPS		
			L1	L2	L3
MDW500	3.05	208, 3Φ	7.6	7.6	10.1
	4	240, 3Φ	8.7	8.7	11.5
MDW500R	4.75	208, 3Φ	11.9	11.9	15.8
	6.25	240, 3Φ	13.5	13.5	18

The supply wire will need to be the correct gauge as described by the National Electrical Code and be rated to at least 167°F (75°C).

¹ Wellslok adapter kits [4 required] will use hex screws to tighten and allow installation on countertops up to 1.5 inches (38 mm) thick.



WELLS BLOOMFIELD, LLC • www.wellsbloomfield.com
 265 Hobson Street • Smithville, Tennessee 37166
 Telephone (800) 264-7827

Printed in the U.S.A. • 2M-Z20759 • Rev A • 03.2017
 The owner is responsible for proper installation as described above. Please refer to the owner's manual for information regarding installation or use.



Wellslok Mounting System

2M-302353 Basic Installation and Extension Kits

BASIC USE

HSW, HT, HW, MDW, MOD, and SS series of round or rectangular, top-mounted, built-in warmers come equipped with the Wellslok mounting system. After getting the warmer positioned correctly into the cutout with the appropriate gasket(s) and sealant applied, as described in the installation instructions for the unit, access the underside and turn each Wellslok tab outward with a screwdriver as shown on the right to secure the warmer to the counter. On countertops thicker than 16 GA steel, Wellslok extension kit[s] will be needed. These kits can accommodate countertops up to 1.5 inches (38 mm) thick. *Wellslok extension kits can only be used with UL listed warmers approved for installation in wood countertops. When installing in custom countertops, please follow the manufacture's "suggested" recommendations or guidelines for installation of heated equipment in their counter material".*

RECTANGULAR EXTENSION KITS

Rectangular extension kits [number 22593] come with hardware to secure a single well up to 12 inches (305 mm) by 20 inches (508 mm) in size. For multiple-well models, additional kits will be required. If your unit is a 4- or 5-well model, then you will need 3 kits for proper installation. On 2- or 3-well models, you will need 2 kits for proper installation. The clips will need to be attached under the countertop and be positioned equally around the unit to assure proper seating. Once all are in place tighten screws until they are flush against the underside of the counter and the unit is secured in place. On some materials, you may wish to place something in between the tip of the screw and the countertop to prevent marring the countertop material.

ROUND EXTENSION KITS

Round extension kits [number 22592] come with hardware to secure one well. The clips will need to be attached under the countertop and be positioned equally around the unit to assure proper seating. Once all are in place tighten screws until they are flush against the underside of the counter and the unit is secured in place. On some materials, you may wish to place something in between the tip of the screw and the countertop to prevent marring the countertop material.

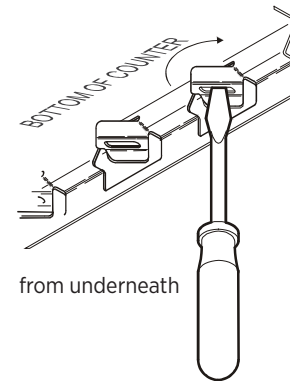
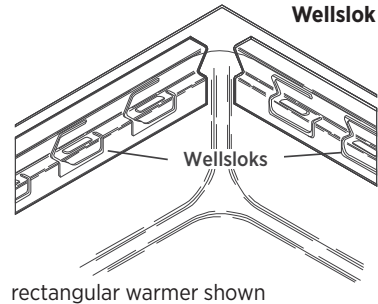

Wellslok extension kit

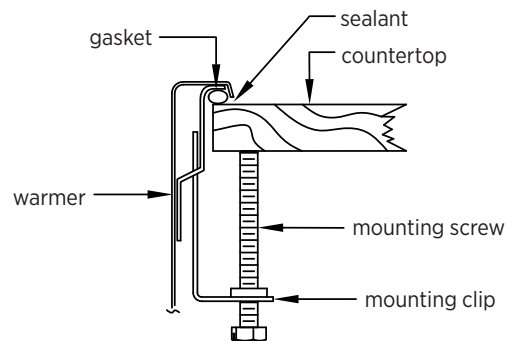

KIT	QUANTITY OF MOUNTING CLIPS	QUANTITY OF SCREWS
22593	10	10
22592	6	6

WELLS MANUFACTURING • www.wells-mfg.com
 265 Hobson Street • Smithville, Tennessee 37166
 Telephone (800) 264-7827

Printed in the U.S.A. • 2M-Z2079 • Rev B • 05.2018
 Specifications are subject to change without notice.

WELLS MANUFACTURING • www.wells-mfg.com
265 Hobson Street • Smithville, Tennessee 37166
Telephone (800) 264-7827

Printed in the U.S.A. • 2M-Z21876 REVE (04-22)
Specifications are subject to change without notice.