



WELLS MANUFACTURING

265 Hobson Street, Smithville, Tennessee 37166

telephone: 800-264-7827

www.wells-mfg.com

421

OWNERS MANUAL

**SELF-CONTAINED
REFRIGERATED COUNTER
TOP SERVER**

**MODEL
RCTS-4**



RCTS-4

**Includes
INSTALLATION
USE & CARE
EXPLODED VIEW
PARTS LIST
WIRING DIAGRAM**

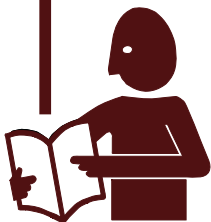

IMPORTANT: DO NOT DISCARD THIS MANUAL

This manual is considered to be part of the appliance and is to be given to the OWNER or MANAGER of the restaurant, or to the person responsible for TRAINING OPERATORS of this appliance. Additional manuals are available from your WELLS DEALER.

THIS MANUAL MUST BE READ AND UNDERSTOOD BY ALL PERSONS USING OR INSTALLING THIS APPLIANCE. Contact your WELLS DEALER if you have any questions concerning installation, operation or maintenance of this equipment.

LIMITED WARRANTY STATEMENT

Unless otherwise specified, all commercial cooking equipment manufactured by WELLS MANUFACTURING is warranted against defects in materials and workmanship for a period of one year from the date of original installation or 18 months from the date of shipment from our factory, whichever comes first, and is for the benefit of the original purchaser only.

THIS WARRANTY IS THE COMPLETE AND ONLY WARRANTY, EXPRESSED OR IMPLIED IN LAW OR IN FACT, INCLUDING BUT NOT LIMITED TO, WARRANTIES OF MERCHANTABILITY OR FITNESS FOR ANY PARTICULAR PURPOSE, AND/OR FOR DIRECT, INDIRECT OR CONSEQUENTIAL DAMAGES IN CONNECTION WITH WELLS MANUFACTURING PRODUCTS. This warranty is void if it is determined that, upon inspection by an authorized service agency, the equipment has been modified, misused, misapplied, improperly installed, or damaged in transit or by fire, flood or act of God. It also does not apply if the serial nameplate has been removed, or if service is performed by unauthorized personnel. The prices charged by Wells

Manufacturing for its products are based upon the limitations in this warranty. Seller's obligation under this warranty is limited to the repair of defects without charge by a Wells Manufacturing factory authorized service agency or one of its sub-service agencies. This service will be provided on customer's premises for non-portable models. Portable models (a device with a cord and plug) must be taken or shipped to the closest authorized service agency, transportation charges prepaid, for service. In addition to restrictions contained in this warranty, specific limitations are shown in the Service Policy and Procedure Guide. Wells Manufacturing authorized service agencies are located in principal cities. This warranty is valid in the United States and Canada and void elsewhere. Please consult your classified telephone directory, your foodservice equipment dealer or contact:

Wells Manufacturing
10 Sunnen Dr., St. Louis MO 63143 USA
phone (314) 678--6314 or fax (314) 781-2714

for information and other details concerning warranty.

SERVICE POLICY AND PROCEDURE GUIDE and ADDITIONAL WARRANTY EXCLUSIONS

1. Resetting of safety thermostats, circuit breakers, over load protectors, and/or fuse replacements are not covered by this warranty unless warranted conditions are the cause.
2. All problems due to operation at voltages or phase other than specified on equipment nameplates are not covered by this warranty. Conversion to correct voltage and/or phase must be the customer's responsibility.
3. All problems due to electrical connections not made in accordance with electrical code requirements and wiring diagrams supplied with the equipment are not covered by this warranty.
4. Replacement of items subject to normal wear, to include such items as knobs, light bulbs; and, normal maintenance functions including adjustments of thermostats, adjustment of micro switches and replacement of fuses and indicating lights are not covered by warranty.
5. Damage to electrical cords and/or plug due to exposure to excessive heat are not covered by this warranty.
6. Full use, care, and maintenance instructions supplied with each machine. Noted maintenance and preventative maintenance items, such as servicing and cleaning schedules, are customer responsibility. Those miscellaneous adjustments noted are customer responsibility. Proper attention to preventative maintenance and scheduled maintenance procedures will prolong the life of the appliance.
7. Travel mileage is limited to sixty (60) miles from an Authorized Service Agency or one of its sub-service agencies.
8. All labor shall be performed during regular working hours. Overtime premium will be charged to the buyer.
9. All genuine Wells replacement parts are warranted for ninety (90) days from date of purchase on non-warranty equipment. This parts warranty is limited only to replacement of the defective part(s). Any use of non-genuine Wells parts completely voids any warranty.
10. Installation, labor, and job check-outs are not considered warranty and are thus not covered by this warranty.
11. Charges incurred by delays, waiting time or operating restrictions that hinder the service technician's ability to perform service are not covered by warranty. This includes institutional and correctional facilities.

SHIPPING DAMAGE CLAIM PROCEDURE

NOTE: For your protection, please note that equipment in this shipment was carefully inspected and packaged by skilled personnel before leaving the factory. Upon acceptance of this shipment, the transportation company assumes full responsibility for its safe delivery.

IF SHIPMENT ARRIVES DAMAGED:

1. **VISIBLE LOSS OR DAMAGE:** Be certain that any visible loss or damage is noted on the freight bill or express receipt, and that the note of loss or damage is signed by the delivery person.
2. **FILE CLAIM FOR DAMAGE IMMEDIATELY:** Regardless of the extent of the damage.

3. **CONCEALED LOSS OR DAMAGE:** if damage is unnoticed until the merchandise is unpacked, notify the transportation company or carrier immediately, and file "CONCEALED DAMAGE" claim with them. This should be done within fifteen (15) days from the date the delivery was made to you. Be sure to retain the container for inspection.

Wells Manufacturing cannot assume liability for damage or loss incurred in transit. We will, however, at your request, supply you with the necessary documents to support your claim.

TABLE OF CONTENTS

WARRANTY	xi
SPECIFICATIONS	1
FEATURES & OPERATING CONTROLS	2
PRECAUTIONS & GENERAL INFORMATION	3
AGENCY LISTING INFORMATION	3
INSTALLATION	4
OPERATION	5
CLEANING INSTRUCTIONS	6
TEMPERATURE ADJUSTMENT	7-8
TROUBLESHOOTING SUGGESTIONS	9
WIRING DIAGRAM	9
EXPLODED VIEW & PARTS LIST	10-11
PARTS & SERVICE	13
CUSTOMER SERVICE DATA	13

INTRODUCTION

Thank You for purchasing this Wells Manufacturing appliance.

Proper installation, professional operation and consistent maintenance of this appliance will ensure that it gives you the very best performance and a long, economical service life.

This manual contains the information needed to properly install this appliance, and to use and care for the appliance in a manner which will ensure its optimum performance.

SPECIFICATIONS

Model No	Voltage	Watts	HP	Amps	Ph	Power Supply	Refrigerant
RCTS-4	120V	240	1/6	2	1	NEMA 5-16P	134A

FEATURES & OPERATING CONTROLS

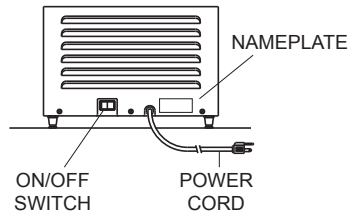

REAR VIEW

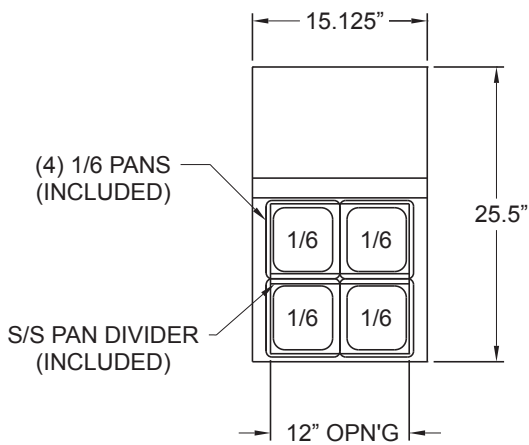

TOP VIEW

CLEARANCE
1" SIDE & REAR

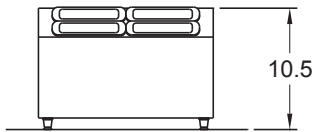

FRONT VIEW

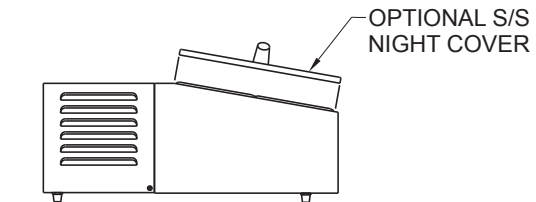

SIDE VIEW

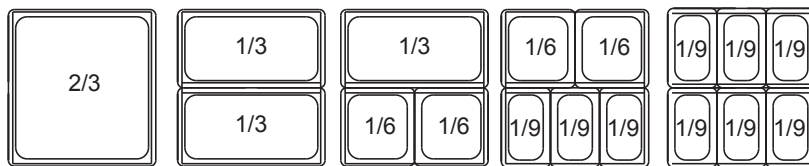

VARIOUS OTHER PAN ARRANGEMENTS

(PANS BY OTHERS)

IL2877

PRECAUTIONS AND GENERAL INFORMATION

This appliance is intended for use in commercial establishments only.

This appliance is designed to hold toppings, condiments, or practically any food at safe temperatures. No other use is recommended or authorized by the manufacturer or its agents.

Operators of this appliance must be familiar with the appliance use, limitations and associated restrictions. Operating instructions must be read and understood by all persons using or installing this appliance.

Cleanliness of this appliance is essential to good sanitation. Read and follow all included cleaning instructions and schedules to ensure the safety of the food product.

Disconnect this appliance from electrical power before performing any maintenance or servicing.

Exposed surfaces of this appliance can be hot to the touch and may cause burns.

The technical content of this manual, including any wiring diagrams, schematics, parts breakdown illustrations and/or adjustment procedures, is intended for use by qualified technical personnel.

Any procedure which requires the use of tools must be performed by a qualified technician and any warranty service must be performed by an approved Wells Service Agent.

This manual is considered to be a permanent part of the appliance. This manual and all supplied instructions, diagrams, schematics, parts breakdown illustrations, notices and labels must remain with the appliance if it is sold or moved to another location.

Unless otherwise noted, this appliance has American sizes on all hardware.



WARNING: ELECTRIC SHOCK HAZARD

All servicing requiring access to non-insulated electrical components must be performed by a factory authorized technician.

DO NOT open any access panel which requires the use of tools. Failure to follow this warning can result in severe electrical shock.



CAUTION: RISK OF DAMAGE

DO NOT connect or energize this appliance until all installation instructions are read and followed. Damage to the appliance will result if these instructions are not followed.

AGENCY LISTING INFORMATION

This appliance is **U** Listed under UL File SA12649 for 120VAC 60Hz only.



INSTALLATION

NOTE: DO NOT discard the carton or other packing materials until you have inspected the appliance for hidden damage and tested it for proper operation. Refer to *SHIPPING DAMAGE CLAIM PROCEDURE* on the inside front cover of this manual.



WARNING: RISK OF INJURY

Installation procedures must be performed by a qualified technician with full knowledge of all applicable electrical and plumbing codes. Failure can result in personal injury and property damage.

IMPORTANT:

This appliance must be plugged into a properly grounded receptacle. Contact a licensed electrician to install and connect a proper receptacle.

IMPORTANT:

Damage due to being connected to the wrong voltage or phase is NOT covered by warranty.

UNPACKING & INSPECTION

Carefully remove the appliance from the carton. Remove all protective plastic film, packing materials and accessories from the Appliance before connecting electrical power or otherwise performing any installation procedure.

Carefully read all instructions in this manual and the Installation Instruction Sheet packed with the appliance before starting any installation.

Read and understand all labels and diagrams attached to the appliance.

Carefully account for all components and accessories before discarding packing materials. Store all accessories in a convenient place for later use.

IMPORTANT

This unit should NEVER be positioned upside down or on its side. If the unit arrived or was stored in any position other than "THIS END UP" as marked on the shipping container, then allow the unit to set upright 24 hours before applying power or turning on the unit. Failure to do this will cause the unit to function incorrectly. The unit will not be able to cool to the desired temperature.

COMPONENTS

4 ea 1/6 PANS

SET-UP NOTES

1. Setup the appliance only on a firm, level, non-combustible surface. Verify local codes for requirements. Concrete, tile, terrazzo or metal surfaces are recommended. Metal over combustible material may not meet code for non-combustible surfaces.
2. The adjustable legs come installed from the factory, with a spirit level, check that the appliance is level front-to-back and side-to-side. Verify that the unit sits firmly ON ALL FOUR LEGS.
3. The lower portions of the legs are adjustable by turning; adjust as required to level the appliance. All four legs must be adjusted to firmly contact the counter.
4. Avoid storing flammable or combustible materials in, on or near the appliance.

ELECTRICAL HOOK-UP

1. Refer to the nameplate. Verify the electrical service power. Voltage and phase must match the nameplate specifications. Plugging the warmer into the wrong voltage can severely damage the unit or cause noticeable decreased performance.
2. Your unit is equipped with a grounded electrical cord. This cord must be plugging into a properly grounded electrical receptacle.

SUGGESTIONS: Inspect each pan insert for thorough cleaning. Additional hand cleaning may be necessary to insure complete food removal.

If detergent is used, items must be rinsed with clean water prior to use.

IMPORTANT:

DO NOT put water or ice in the well of the server.

PRE-CHILLING THE SERVER

1. Turn power switch on.
2. Place desired pan(s) or inset(s) with appropriate adapter top on server.
3. Allow unit to run for approximately 30 minutes

OPERATION

1. Always use an inset. **DO NOT** place food directly into the server.
2. **DO NOT** use metal tools, steel wool, or caustic or abrasive cleanser to any metal surface on the unit.

CLEANING INSTRUCTIONS



**WARNING:
SHOCK
HAZARD**

Turn power switch OFF and disconnect unit from electric power before cleaning.

IMPORTANT:

NEVER use any corrosive cleaners, use only cleaners approved for stainless steel.

PREPARATION

Turn power switch *OFF*
Unplug from electrical power
Remove Removable Pans

FREQUENCY

Daily, or as needed

TOOLS

Bottle Brush, Soft Bristle Brush
Soft Cloth or Sponge

CLEANING

1. Turn power switch OFF and unplug unit.
2. Remove (optional) cover., clean using warm water and mild detergent.
3. Remove pans and pan support, clean using warm water and mild detergent.
4. Clean the stainless steel using mild detergent, warm water and soft cloth or sponge. Dry using a clean cloth. **DO NOT** use any abrasive pads or wire brushes.

Procedure is complete.

TEMPERATURE ADJUSTMENT

RCTS

1. The temperature has been preset at the factory to meet most applications.
2. If temperature adjustments are required, the pressure switch, located on the condensing unit, is adjustable. Temperature adjustment must be performed by a qualified refrigeration personnel only.
3. Normal temperature setting would be 41°F.

The LCD Display provides a readout of the sensor temperature during normal operation. Use the following to change the setpoint temperature:

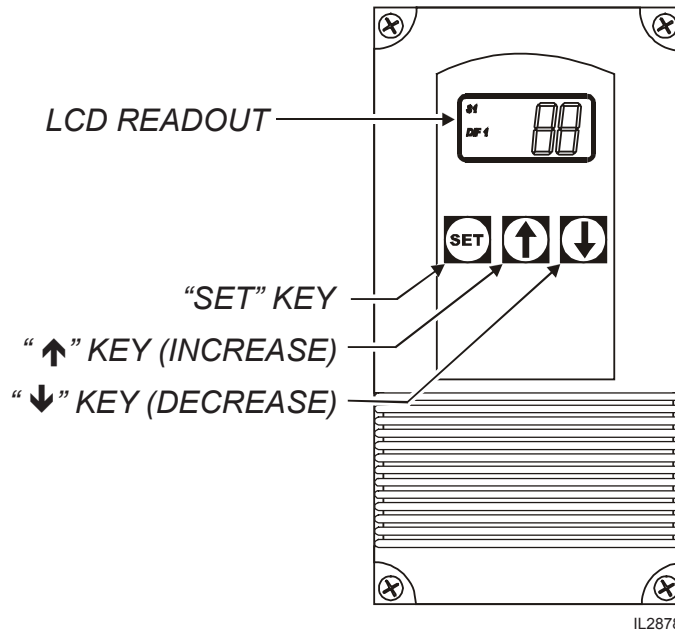

IMPORTANT:

DO NOT adjust the differential settings of the refrigeration system. Field adjustments of the differential settings must be made by qualified refrigeration personnel only. Unauthorized adjustment of the differential settings will void the warranty.

The temperature setting of the NSF-7 Refrigerated Cold Pan has been pre-set at the factory to meet most applications. An electronic temperature control maintains food temperature between 33°F and 44°F.

1. To start programming, press SET key once. This will access the Fahrenheit/Celsius mode. The readout will show the current status, either F (degrees Fahrenheit) or C (degrees Celsius). Press either “up arrow” (↑) or “down arrow” (↓) to toggle between F and C designation.
2. Press SET again to access the setpoint. The LCD will display the current setpoint, and the S1 annunciator will blink off and on to indicate that control is in the setpoint mode.
Press either “up arrow” (↑) to increase the setpoint, or “down arrow” (↓) to decrease the setpoint to the desired temperature. Factory setpoint is 41°F.

TEMPERATURE ADJUSTMENT

IMPORTANT:

DO NOT adjust the differential settings of the refrigeration system. Field adjustments of the differential settings must be made by qualified refrigeration personnel only. Unauthorized adjustment of the differential settings will void the warranty.

NOTE:

The controller has both “heating” and “cooling” modes. Heating mode is not used on the RCTS-series units. The control must be set to “cooling” (C1) for proper operation of the cold pan.

3. Press the SET key again to access the differential. The LCD will display the current differential, and the DIF1 annunciator will blink off and on to indicate that control is in the differential mode.

IMPORTANT: DO NOT adjust the differential settings of the refrigeration system. Field adjustments of the differential settings must be made by qualified refrigeration personnel only. Unauthorized adjustment of the differential settings will void the warranty.

Press either “up arrow” (↑) to increase the differential, or “down arrow” (↓) to decrease the differential to the desired setting. Factory differential is 3°F.

4. Press the **SET** key again to access the Heating / Cooling mode. The LCD will display the current mode. Either “C1” for cooling or “H1” for heating. The control must be set to C1 for proper operation of the cold pan.
5. Press the **SET** key again to complete programming. Programming ends automatically if no keys are pressed for 30 seconds. Any settings that have been input to the control will be accepted at that time.
6. Control settings are stored in non-volatile memory. Loss of power to the unit will not require reprogramming.

TROUBLESHOOTING SUGGESTIONS

SYMPTOM	PROBABLE CAUSE	SUGGESTED REMEDY
No power to unit	Unit unplugged or circuit breaker tripped	Plug unit into appropriate receptacle
		Reset circuit breaker
Unit will not run	Power switch off	Turn switch ON
	Damaged power cord	Replace power cord
	Damaged power switch	Replace switch
	Damaged motor	Replace motor

WIRING DIAGRAM

RCTS WIRING DIAGRAM

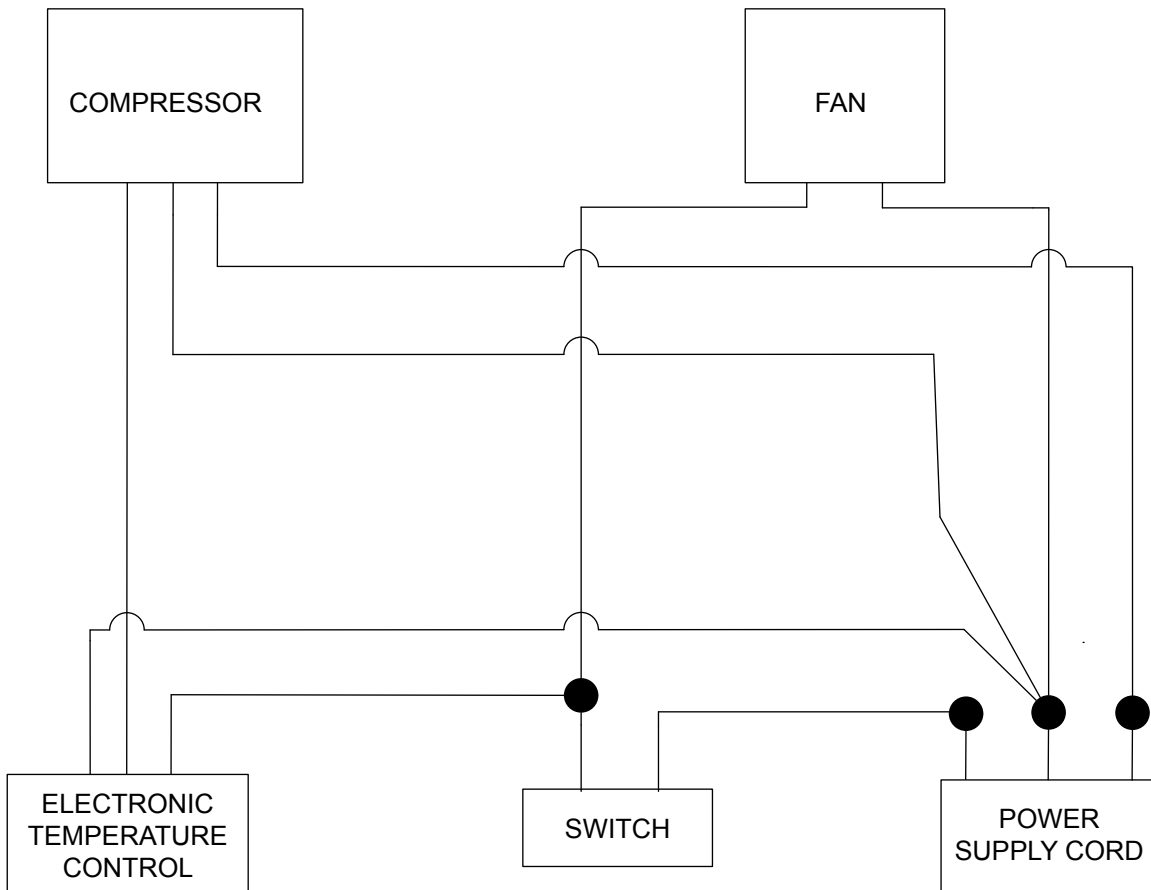

EXPLODED VIEW: RCTS-4

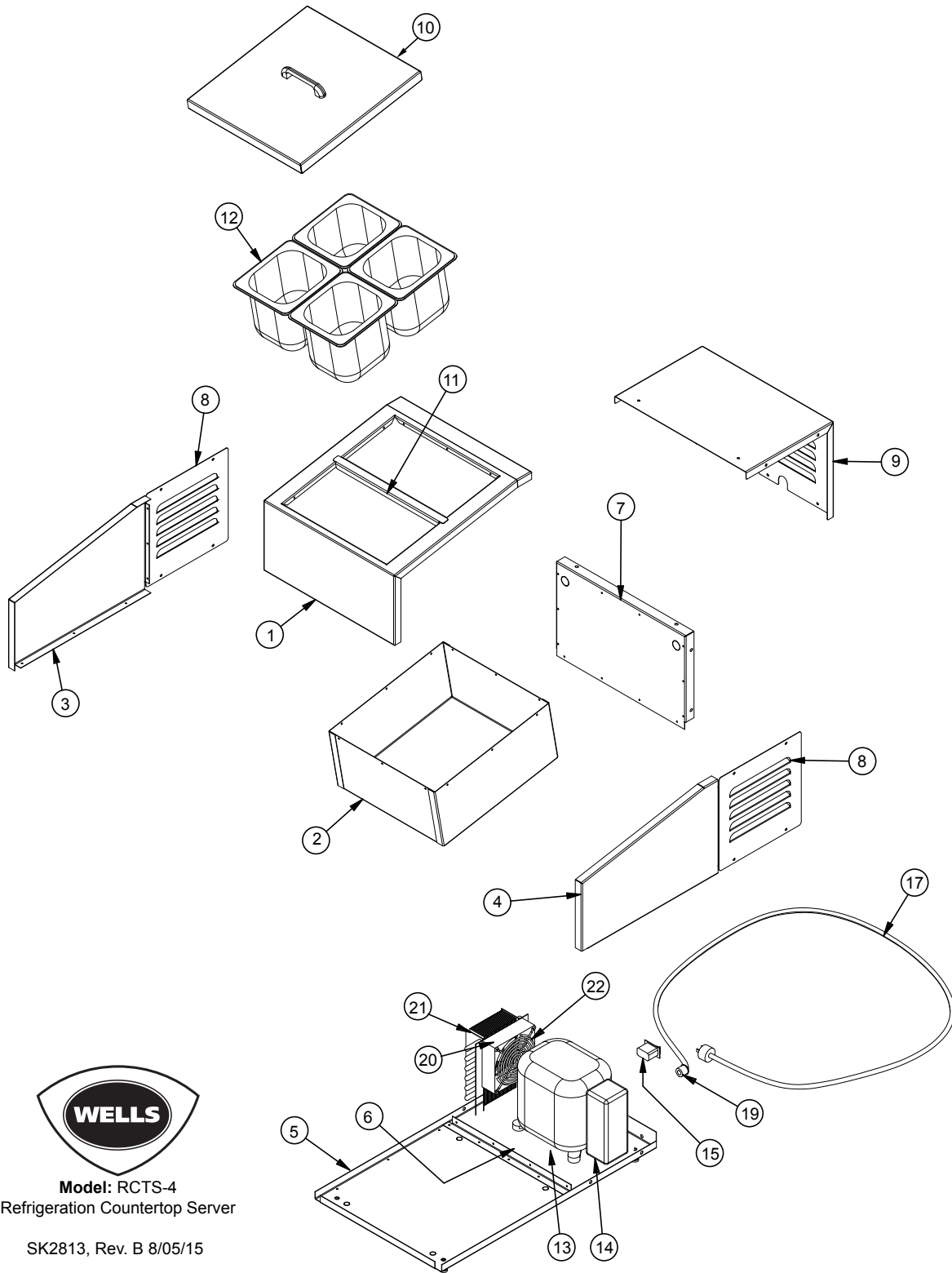

Model: RCTS-4
Refrigeration Countertop Server

SK2813, Rev. B 8/05/15

M421 p/n 2M-Z20013 Owners Manual Refrigerated Countertop Server, RCTS-4

Model: RCTS-4, REFRIGERATED COUNTER TOP SERVER			
Fig. No.	Part No.	Qty	Description
1		1	TOP
2		1	PAN
3		1	SIDE PANEL, LEFT
4		1	SIDE PANEL, RIGHT
5		1	BOTTOM PANEL
6		1	BOTTOM PANEL ANGLE
7		1	ENCLOSURE PANEL
8		1	LOUVERED PANEL
9		1	LOUVERED PANEL
10	50-RCTS-4-CVR	1	NIGHT COVER
11	2V-Z19295	1	DIVIDER BAR
12	2L-Z19296	4	PAN, 6"D X 6.9375" L X 6.375" W
13	2U-Z19297	1	COMPRESSOR
14	2E-Z17505	1	TEMP CONTROL
15	2E-Z3808	1	SWITCH, ROCKER ON-ON
16	2R-Z19299	4	FOOT, ADJUSTABLE
17	2E-Z19300	1	4FT CORD w/NEMA 5-15P PLUG
19		1	STRAIN RELIEF
20	2U-Z19301	1	FAN
21		1	CONDENSER COIL
22	2R-Z19302	1	FAN GRILL

NOTES:

PARTS & SERVICE

DESCRIPTION

PART NO.

IMPORTANT: Use only factory authorized service parts and replacement filters.

For factory authorized service, or to order factory authorized replacement parts, contact your Wells authorized service agency, or call:

Wells Manufacturing

10 Sunnen Dr.,
St. Louis MO 63143 USA

Service Dept.

phone: (314) 678-6314
fax: (314) 781-2714

Service Parts Department can supply you with the name and telephone number of the WELLS AUTHORIZED SERVICE AGENCY nearest you.

CUSTOMER SERVICE DATA

please have this information available if calling for service

RESTAURANT _____ LOCATION _____
INSTALLATION DATE _____ TECHNICIAN _____
SERVICE COMPANY _____
ADDRESS _____ STATE _____ ZIP _____
TELEPHONE NUMBER (____) _____ - _____
EQUIPMENT MODEL NO. _____
EQUIPMENT SERIAL NO. _____
VOLTAGE: (check one) 120 220 240



Wells Bloomfield proudly supports CFESA
Commercial Food Equipment Service Association

SERVICE TRAINING - QUALITY SERVICE



CUSTOMER SATISFACTION



WELLS MANUFACTURING

265 Hobson Street, Smithville, Tennessee 37166

telephone: 800-264-7827

fax: 314-781-2714

www.wells-mfg.com