

WELLS MANUFACTURING
10 Sunnen Dr., St. Louis, MO 63143
telephone: 314-678-6314
fax: 314-781-2714
www.wellsbloomfield.com

041



Model RW2HD



Model RWN2

OWNERS MANUAL

**FREE STANDING
DRAWER WARMERS
with THERMOSTATIC
CONTROL**

MODELS

**RW1HD
RW2HD
RW3HD**

**RWN1
RWN2
RWN3**

**Includes
INSTALLATION
USE & CARE
EXPLODED VIEW
PARTS LIST
WIRING DIAGRAM**

IMPORTANT: DO NOT DISCARD THIS MANUAL

This manual is considered to be part of the appliance and is to be given to the OWNER or MANAGER of the restaurant, or to the person responsible for TRAINING OPERATORS of this appliance. Additional manuals are available from your WELLS DEALER.

THIS MANUAL MUST BE READ AND UNDERSTOOD BY ALL PERSONS USING OR INSTALLING THIS APPLIANCE. Contact your WELLS DEALER if you have any questions concerning installation, operation or maintenance of this equipment.

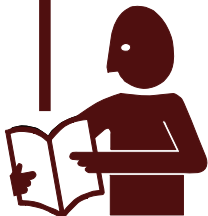

LIMITED WARRANTY STATEMENT

Unless otherwise specified, all commercial cooking equipment manufactured by WELLS MANUFACTURING is warranted against defects in materials and workmanship for a period of one year from the date of original installation or 18 months from the date of shipment from our factory, whichever comes first, and is for the benefit of the original purchaser only.

THIS WARRANTY IS THE COMPLETE AND ONLY WARRANTY, EXPRESSED OR IMPLIED IN LAW OR IN FACT, INCLUDING BUT NOT LIMITED TO, WARRANTIES OF MERCHANTABILITY OR FITNESS FOR ANY PARTICULAR PURPOSE, AND/OR FOR DIRECT, INDIRECT OR CONSEQUENTIAL DAMAGES IN CONNECTION WITH WELLS MANUFACTURING PRODUCTS. This warranty is void if it is determined that, upon inspection by an authorized service agency, the equipment has been modified, misused, misapplied, improperly installed, or damaged in transit or by fire, flood or act of God. It also does not apply if the serial nameplate has been removed, or if service is performed by unauthorized personnel. The prices charged

by Wells Manufacturing for its products are based upon the limitations in this warranty. Seller's obligation under this warranty is limited to the repair of defects without charge by a Wells Manufacturing factory authorized service agency or one of its sub-service agencies. This service will be provided on customer's premises for non-portable models. Portable models (a device with a cord and plug) must be taken or shipped to the closest authorized service agency, transportation charges prepaid, for service. In addition to restrictions contained in this warranty, specific limitations are shown in the Service Policy and Procedure Guide. Wells Manufacturing authorized service agencies are located in principal cities. This warranty is valid in the United States and Canada and void elsewhere. Please consult your classified telephone directory, your food-service equipment dealer or contact:

Wells Manufacturing
10 Sunnen Dr., St. Louis MO 63143 USA
phone (314) 678-6314 or fax (314) 781-2714

for information and other details concerning warranty.

SERVICE POLICY AND PROCEDURE GUIDE and ADDITIONAL WARRANTY EXCLUSIONS

1. Resetting of safety thermostats, circuit breakers, over load protectors, and/or fuse replacements are not covered by this warranty unless warranted conditions are the cause.
2. All problems due to operation at voltages or phase other than specified on equipment nameplates are not covered by this warranty.
Conversion to correct voltage and/or phase must be the customer's responsibility.
3. All problems due to electrical connections not made in accordance with electrical code requirements and wiring diagrams supplied with the equipment are not covered by this warranty.
4. Replacement of items subject to normal wear, to include such items as knobs, light bulbs; and, normal maintenance functions including adjustments of thermostats, adjustment of micro switches and replacement of fuses and indicating lights are not covered by warranty.
5. Damage to electrical cords and/or plug due to exposure to excessive heat are not covered by this warranty.
6. Full use, care, and maintenance instructions supplied with each machine. Noted maintenance and preventative maintenance items, such as servicing and cleaning schedules, are customer responsibility. Those miscellaneous adjustments noted are customer responsibility. Proper attention to preventative maintenance and scheduled maintenance procedures will prolong the life of the appliance.
7. Travel mileage is limited to sixty (60) miles from an Authorized Service Agency or one of its sub-service agencies.
8. All labor shall be performed during regular working hours. Overtime premium will be charged to the buyer.
9. All genuine Wells replacement parts are warranted for ninety (90) days from date of purchase on non-warranty equipment. This parts warranty is limited only to replacement of the defective part(s). Any use of non-genuine Wells parts completely voids any warranty.
10. Installation, labor, and job check-outs are not considered warranty and are thus not covered by this warranty.
11. Charges incurred by delays, waiting time or operating restrictions that hinder the service technician's ability to perform service are not covered by warranty. This includes institutional and correctional facilities.

SHIPPING DAMAGE CLAIM PROCEDURE

NOTE: For your protection, please note that equipment in this shipment was carefully inspected and packaged by skilled personnel before leaving the factory. Upon acceptance of this shipment, the transportation company assumes full responsibility for its safe delivery.

IF SHIPMENT ARRIVES DAMAGED:

1. **VISIBLE LOSS OR DAMAGE:** Be certain that any visible loss or damage is noted on the freight bill or express receipt, and that the note of loss or damage is signed by the delivery person.
2. **FILE CLAIM FOR DAMAGE IMMEDIATELY:** Regardless of the extent of the damage.
3. **CONCEALED LOSS OR DAMAGE:** if damage is unnoticed until the merchandise is unpacked, notify the transportation company or carrier immediately, and file "CONCEALED DAMAGE" claim with them. This should be done within fifteen (15) days from the date the delivery was made to you. Be sure to retain the container for inspection.

Wells Manufacturing cannot assume liability for damage or loss incurred in transit. We will, however, at your request, supply you with the necessary documents to support your claim.

TABLE OF CONTENTS

WARRANTY	xi
SPECIFICATIONS	1
FEATURES & OPERATING CONTROLS	2
PRECAUTIONS & GENERAL INFORMATION	3
AGENCY LISTING INFORMATION	3
INSTALLATION	4
OPERATION	6
CLEANING INSTRUCTIONS	8
TROUBLESHOOTING SUGGESTIONS	9
MAINTENANCE INSTRUCTIONS	10
EXPLODED VIEW & PARTS LIST	11
WIRING DIAGRAM	13
PARTS & SERVICE	17
CUSTOMER SERVICE DATA	17

INTRODUCTION

Thank You for purchasing this Wells Manufacturing appliance.

Proper installation, professional operation and consistent maintenance of this appliance will ensure that it gives you the very best performance and a long, economical service life.

This manual contains the information needed to properly install this appliance, and to use and care for the appliance in a manner which will ensure its optimum performance.

SPECIFICATIONS

MODELS	VOLTS 50/60 Hz 1 ϕ	WATTS	AMPS	POWER CORD
RW1HD, RWN1	120 VAC	450 W	3.8	NEMA-5-15P
	208/240 VAC	338/450 W	1.6/1.9	NEMA 6-15P
RW2HD, RWN2	120 VAC	900 W	7.5	NEMA-5-15P
	208/240 VAC	676/900 W	3.3/3.8	NEMA 6-15P
RW3HD, RWN3	120 VAC	1350 W	11.3	NEMA-5-15P
	208/240 VAC	1014/1350 W	4.9/5.6	NEMA 6-15P

FEATURES & OPERATING CONTROLS

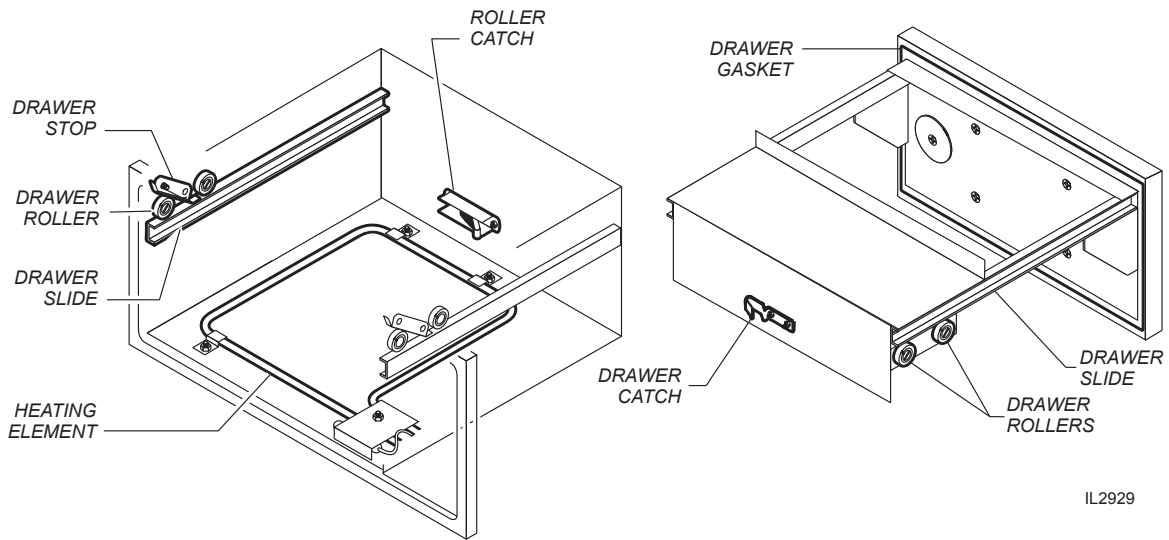
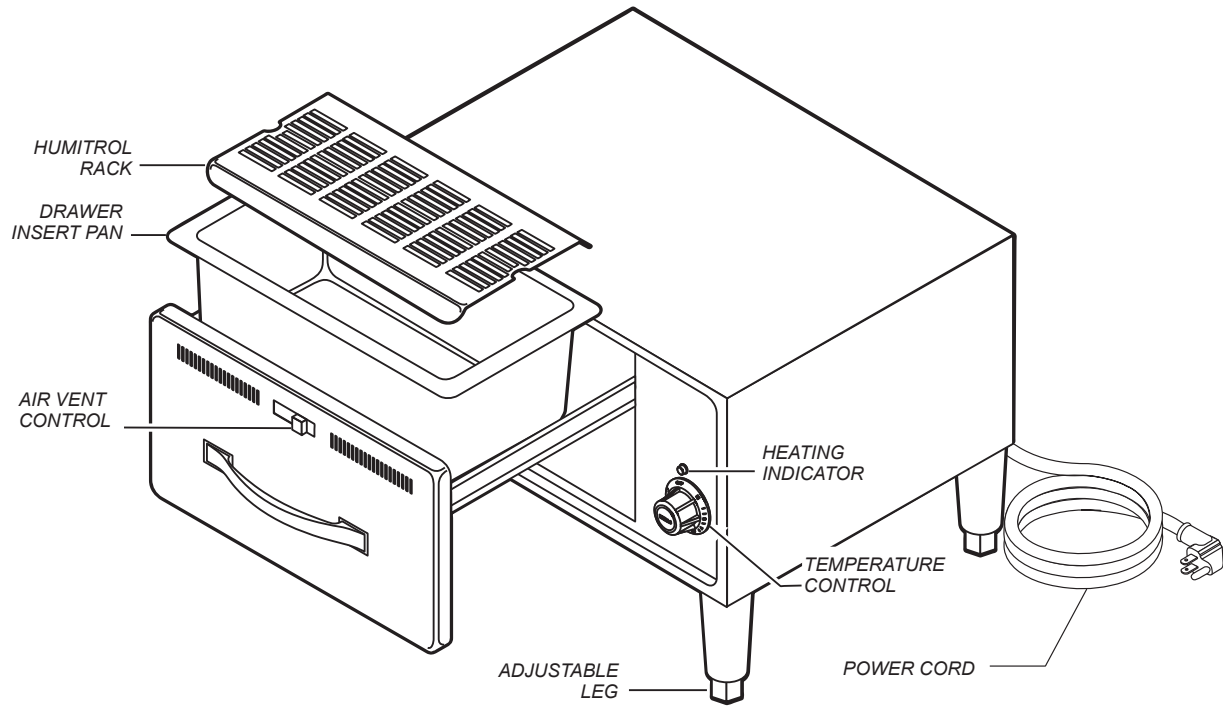

IL2929

PRECAUTIONS AND GENERAL INFORMATION

This appliance is intended for use in commercial establishments only.

This appliance is intended to prepare food for human consumption. No other use is recommended or authorized by the manufacturer or its agents.

Operators of this appliance must be familiar with the appliance use, limitations and associated restrictions. Operating instructions must be read and understood by all persons using or installing this appliance.

Cleanliness of this appliance is essential to good sanitation. Read and follow all included cleaning instructions and schedules to ensure the safety of the food product.

Disconnect this appliance from electrical power before performing any maintenance or servicing.

DO NOT submerge this appliance in water. This appliance is not jet stream approved. Do not direct water jet or steam jet at this appliance, or at any control panel or wiring. Do not splash or pour water on, in or over any controls, control panel or wiring. Do not wash floor around this appliance with water or steam jet.

Exposed surfaces of this appliance can be hot to the touch and may cause burns.

Heating element will be very hot when in use. Contact may cause serious burns.

The technical content of this manual, including any wiring diagrams, schematics, parts breakdown illustrations and/or adjustment procedures, is intended for use by qualified technical personnel.

Any procedure which requires the use of tools must be performed by a qualified technician.

This manual is considered to be a permanent part of the appliance. This manual and all supplied instructions, diagrams, schematics, parts breakdown illustrations, notices and labels must remain with the appliance if it is sold or moved to another location.

This appliance is made in the USA. Unless otherwise noted, this appliance has American sizes on all hardware.



WARNING: ELECTRIC SHOCK HAZARD

All servicing requiring access to non-insulated electrical components must be performed by a factory authorized technician. DO NOT open any access panel which requires the use of tools. Failure to follow this warning can result in severe electrical shock.



CAUTION: RISK OF DAMAGE

DO NOT connect or energize this appliance until all installation instructions are read and followed. Damage to the appliance will result if these instructions are not followed.



CAUTION: HOT SURFACE



Exposed surfaces can be hot to the touch and may cause burns.

AGENCY LISTING INFORMATION

This appliance conforms to NSF Standard 4 for sanitation only if installed in accordance with the supplied Installation Instructions and maintained according to the instructions in this manual.

IMPORTANT:

RW- models are **NOT** NSF approved for potentially hazardous foods.

This appliance is  and  Listed under UL File E6070 for 120V, 208V and 240V.



STD 4



E6070



E6070

INSTALLATION

NOTE: DO NOT discard the carton or other packing materials until you have inspected the appliance for hidden damage and tested it for proper operation. Refer to SHIPPING DAMAGE CLAIM PROCEDURE on the inside front cover of this manual.



WARNING: RISK OF INJURY

Installation procedures must be performed by a qualified technician with full knowledge of all applicable electrical and plumbing codes. Failure can result in personal injury and property damage.

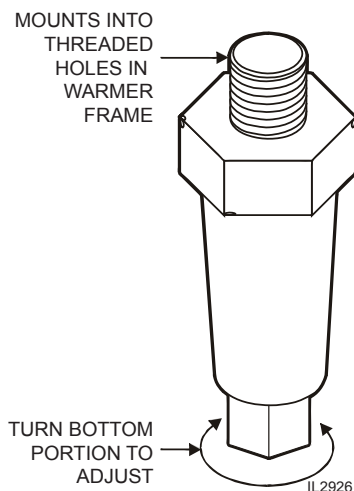

UNPACKING & INSPECTION

Carefully remove the appliance from the carton. Remove all protective plastic film, packing materials and accessories from the Appliance before connecting electrical power or otherwise performing any installation procedure.

Carefully read all instructions in this manual and the Installation Instruction Sheet packed with the appliance before starting any installation.

Read and understand all labels and diagrams attached to the appliance.

Carefully account for all components and accessories before discarding packing materials. Store all accessories in a convenient place for later use.

COMPONENTS

- 1 - 3 ea. DRAWERS (qty. depends on model)
- 1 - 3 ea. HUMITROL RACKS (if ordered with unit)

SETUP

Install adjustable legs or optional casters, one on each corner of the appliance, in the holes provided.

Verify that the unit sits firmly on ALL FOUR legs. With a spirit level, check that the appliance is level front-to-back and side-to-side. With the adjustable legs, adjust as required to level the appliance. All four legs must be adjusted to firmly contact the floor in order to prevent tipping.

If drawers were removed during installation, install drawer(s) in unit:

- a. Check the roller catch inside the cabinet. The spring-loaded roller arm must be extended.
- b. With the front of the drawer assembly tipped downward, engage the roller on the drawer with the cabinet drawer slide.
- c. Raise the drawer to the horizontal position until the drawer-mounted slide engages the dual roller assembly on the cabinet.
- d. Slide the drawer in until the catch engages. The drawer should remain tightly closed.
- e. Slide the drawer out. The drawer stop should prevent the drawer from coming all of the way out.
- f. Install drawer insert pans.

Avoid storing flammable or combustible materials in, on or near the appliance.

ELECTRICAL

Refer to electrical specifications on page 1. Circuit must meet or exceed the amperage and wattage requirements listed.

120 Volt units require a properly grounded NEMA 5-15R receptacle:

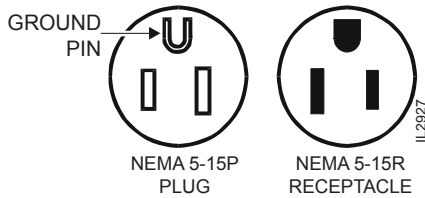

208/240 Volt units require a properly grounded NEMA 6-15R receptacle:

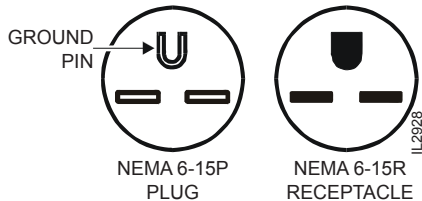

WARNING: SHOCK HAZARD

All servicing requiring access to non-insulated electrical components must be performed by a factory authorized technician. DO NOT open any access panel which requires the use of tools. Failure to follow this warning can result in severe electrical shock.



CAUTION: RISK OF DAMAGE

DO NOT connect or energize this appliance until all installation instructions are read and followed. Damage to the appliance will result if these instructions are not followed.



CAUTION: SHOCK HAZARD

The ground prong of the power cord is part of a system designed to protect you from electric shock in the event of internal damage. DO NOT cut off the large round ground prong, or twist a blade to fit an existing receptacle.

IMPORTANT:

Contact a licensed electrician to install and connect electrical power to the appliance.

IMPORTANT:

Damage due to being connected to the wrong voltage or phase is NOT covered by warranty.

OPERATION



CAUTION: HOT SURFACE

Exposed surfaces can be hot to the touch and may cause burns.

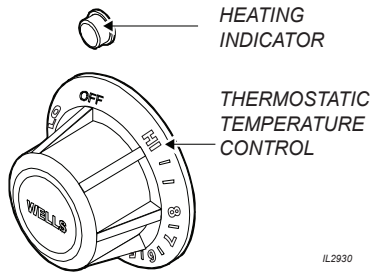

IL2930

NOTE:

The chart below is intended as a guide ONLY. Your own experience with this appliance, type of foods and method of operation will enable you to determine the temperature control and air vent settings best suited to your operation.

HEATING OPTIONS

1. Moist heat with Humitrol Rack:
 - a. MOIST operation prevents food from drying out as heat is applied to the warming chamber.
 - b. To set for MOIST operation, remove the Humitrol Rack from bottom of drawer insert pan and carefully pour approximately 2 quarts of water ($\frac{1}{2}$ " depth) into the pan. Reinstall rack.
 - c. When the drawer is closed, the Humitrol Rack allows water vapor to rise through the stored product in the drawer. The Humitrol Rack also decreases the sloshing effect of the water in the pan when the drawer is opened.
 - d. Place the food directly on the rack. The rack is designed to support the food off of the steam vents, where water droplets may form.
 - e. Check the water level in the pan periodically, and add water when necessary.
 - f. Set the front air vent between fully closed and half-open. Actual setting will depend upon the type and amount of product stored in the drawer, the temperature setting, and the frequency with which the drawer is opened.
2. Moist heat with pans:
 - a. This Wells warmer is designed to accommodate any combination of standard-size, steam table pans.
 - b. Place a small amount of water in drawer pan. Place the steam table pans in the drawer pan.
 - c. Check the water level in the pan periodically, and add water when necessary.
3. Dry heat:
 - a. For some applications, you may want to store previously prepared foods in a dry-heat environment. To do so, place the food directly into the empty (i.e. no water) drawer pan.

OPERATING CHART FOR DRAWER WARMERS

PRODUCT TYPE	RECOMMENDED STORAGE TEMP.		TYPE OF HEAT	CONTROL SETTINGS	AIR VENT SETTINGS
Hard Rolls	160-185°F	71-85°C	Dry	7-8	Full Open
Soft Rolls	150-175°F	65-79°C	Moist	6-7	Open - $\frac{1}{2}$
Vegetables	175-185°F	79-85°C	Moist	7-8	Open - $\frac{1}{2}$
Meats	165-185°F	74-85°C	Dry	6-8	Full Open
Fish	165-185°F	74-85°C	Moist	6-8	Closed
Casseroles	150-175°F	65-79°C	Dry	6-7	Full Open
Pies, Desserts	160-185°F	65-85°C	Dry	6-7	Full Open
Taco Shells	150-170°F	65-76°C	do not put water in the pan	4-6	Full Open
Corn Chips	150-170°F	65-76°C		4-6	Full Open

OPERATION

1. Determine the type of food to be warmed.
2. Refer to the chart on page 6 to determine the type of heat required.
3. Set the air vent control for the type of heat, and rotate the thermostat knob to the temperature setting desired.
4. Allow warmer to pre-heat for approximately 30 minutes before use.

DO'S and DON'TS

1. DO Always use a drawer pan.
DO NOT Place food directly into the warmer cavity.
2. DO Check water level in moist-operation warmer frequently during use.
DO Use a Humitrol Rack or Insets to hold food for moist operation.
3. DO Use warm water to add to the pan during moist operation.
DO NOT Put ice into a warmer pan. Ice in the pan will cause condensation on the inside of the warmer cavity.



**CAUTION:
HOT SURFACE**

Exposed surfaces can be hot to the touch and may cause burns.



**CAUTION:
SHOCK HAZARD**

DO NOT splash or pour water onto control panel or wiring.

IMPORTANT:

DO NOT place food directly into the warmer cavity. Always use a drawer pan.

IMPORTANT:

DO NOT put ice into a warmer pan. Ice in the pan will cause condensation on the inside of the warmer cavity. Damage caused by this type of condensation is NOT covered by warranty.

CLEANING INSTRUCTIONS



CAUTION: SHOCK HAZARD

Disconnect appliance from electric power before cleaning.



CAUTION: HOT SURFACE

Exposed surfaces can be hot to the touch and may cause burns. Allow appliance to cool before cleaning.

PRECAUTIONS: Turn control knob to OFF.
Allow drawers to cool before proceeding.
Remove drawer pans and Humitrol racks.

FREQUENCY: Minimum - Daily

TOOLS: Warm water and mild detergent
Clean cloth or sponge

1. Remove drawers from warmer:
 - a. Pull warmer drawer out until fully extended.
 - b. Slide finger along left and right slide rail until you reach the latches (located at the front end of the cabinet-mounted rails) Press down on both left and right latch.
 - c. Pull drawer away from warmer.

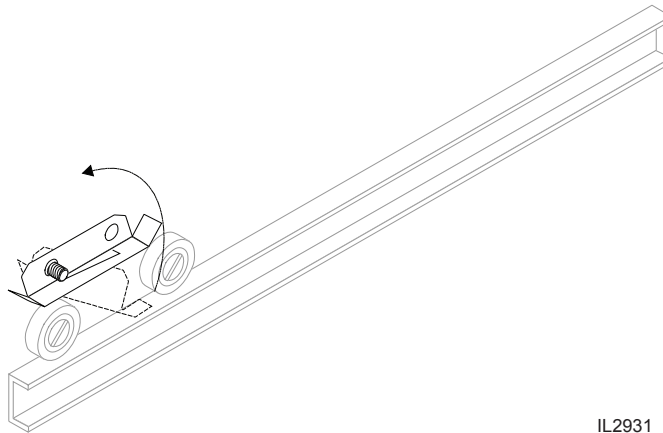

2. Clean drawers, drawer pans, Humitrol Racks and/or insets with warm water and mild detergent.
Rinse all components thoroughly with clear water.
Dry all components prior to reinstalling them in warmer.
3. Sweep crumbs and other debris from warmer cavity.
4. Clean the outside of the unit by wiping with a clean cloth or sponge, warm water and mild detergent. Dry with a clean cloth, then wipe with a polish formulated for stainless steel.
5. It is important to keep the slide rails clear and free from debris. Periodic cleaning of the slide rails and other adjoining parts is necessary to assure smooth drawer operation.
6. Check drawer rollers. Be sure they roll freely and that the slide rails are free from debris.
7. Be sure cabinet-mounted drawer catch roller is "up", then re-install drawers.

TROUBLESHOOTING SUGGESTIONS

SYMPTOM	POSSIBLE CAUSE	SUGGESTED REMEDY
No lights or heat (all drawers)	Warmer unplugged	Plug warmer into appropriate receptacle
	Circuit breaker off or tripped	Reset circuit breaker
	Internal damage	Contact an Authorized Wells Service Agency for repairs.
No heat (one drawer)	Temperature control not set	Set for desired temperature.
	Internal damage	Contact an Authorized Wells Service Agency for repairs.
Food dries out	Humidity control (air vent) not set	OPEN air vent for dry operation. CLOSE air vent for moist operation.
	Water in pan evaporated or low	Add water to pan.
Food gets soggy	Food contacting water	Use a Humitrol Rack
	Water level too high	Water should be no more than 1/2" deep
	Humidity control (air vent) not set	OPEN air vent for dry operation. CLOSE air vent for moist operation.
Drawer falls open	Catch roller not extended before closing drawer	Be sure catch roller is extended before installing drawer.
	Drawer catch damaged	Contact an Authorized Wells Service Agency for repairs.
Drawer falls out when opened	Drawer stop dirty	Clean and lubricate drawer stop
	Drawer stop damaged	Contact an Authorized Wells Service Agency for repairs.

MAINTENANCE INSTRUCTIONS (continued)



CAUTION: SHOCK HAZARD

Disconnect appliance from electric power before cleaning.



CAUTION: HOT SURFACE

Exposed surfaces can be hot to the touch and may cause burns. Allow appliance to cool before servicing.

ADJUSTMENTS AND LUBRICATION

PRECAUTIONS: Turn control knob to OFF. Unplug warmer. Allow drawers to cool before proceeding. Remove drawer pans and Humitrol racks.

FREQUENCY: Minimum - monthly.
Every 2 weeks recommended.

TOOLS: Screwdrivers, Phillips (+) and flat blade (-).
Nut drivers, 3/8" and 7/16".
Food-grade lubricant.

1. Check slides on cabinet and drawers for cleanliness.
2. Check all rollers on cabinet and drawers for cleanliness and tightness. Lubricate.
3. Check cabinet drawer stops for operation. Stops must "snap" down positively. Clean and adjust as required.
4. Check cabinet heating element fasteners for tightness.
5. Check all cabinet drawer catches for tightness and operation. Lubricate. Be certain roller is "out" before attempting to install drawer.
6. Check thermostat thermo-bulb and capillary tube for condition. Thermo-bulb must be securely mounted in the appropriate holder. Arrange repairs for damaged thermo-bulb or capillary tube.
7. Check drawer faceplate and handle fasteners for tightness.
8. Check drawer catch clip for tightness.
9. For drawers equipped with gaskets, examine condition of gasket. Arrange repairs for torn or damaged gaskets.
10. Reinstall drawers and check for proper operation.

Procedure is complete.

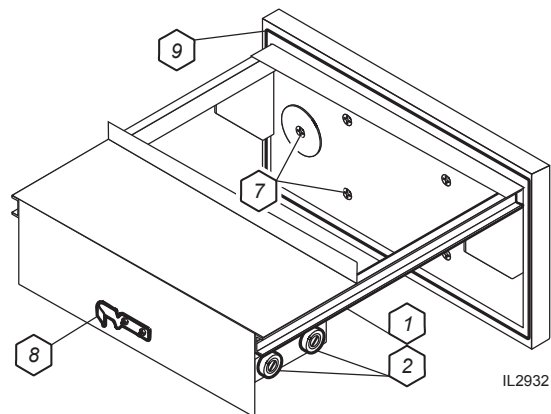
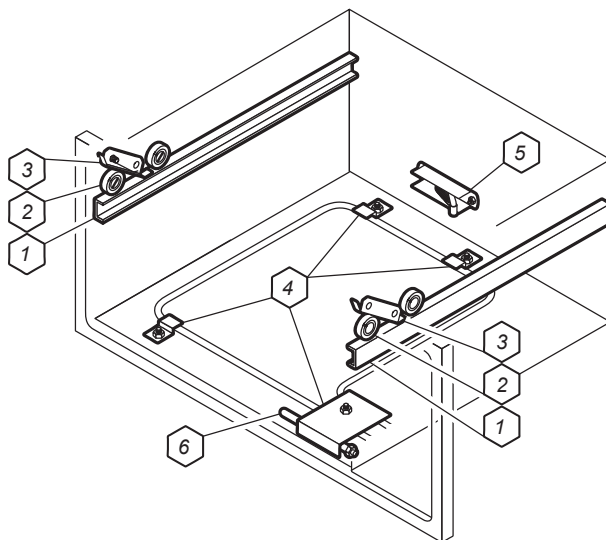

WIRING DIAGRAM

FREE STANDING AND BUILT-IN
Model RW-Series with Cap & bulb thermostat

VOLTS	AMPERES			HZ
	1-DWR	2-DWR	3-DWR	
120	3.8	7.5	11.3	50
208	1.6	3.3	4.9	/60
230	1.8	3.6	5.4	
240	1.9	3.8	5.6	

POWER CORD STANDARD ON COUNTER-TOP MODELS
POWER CORD OPTIONAL ON BUILT-IN MODELS

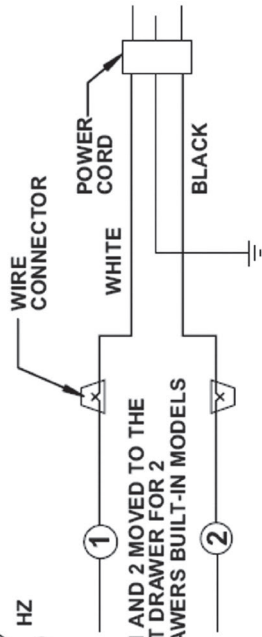

SINGLE DRAWER

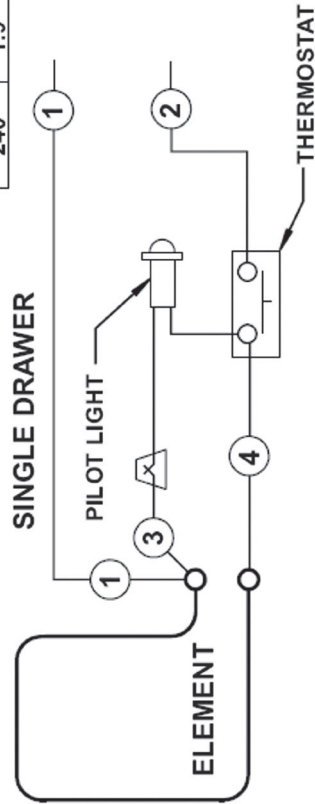

NOTE:
WIRES #1 AND 2 MOVED TO THE
TOP MOST DRAWER FOR 2
OR 3 DRAWERS BUILT-IN MODELS

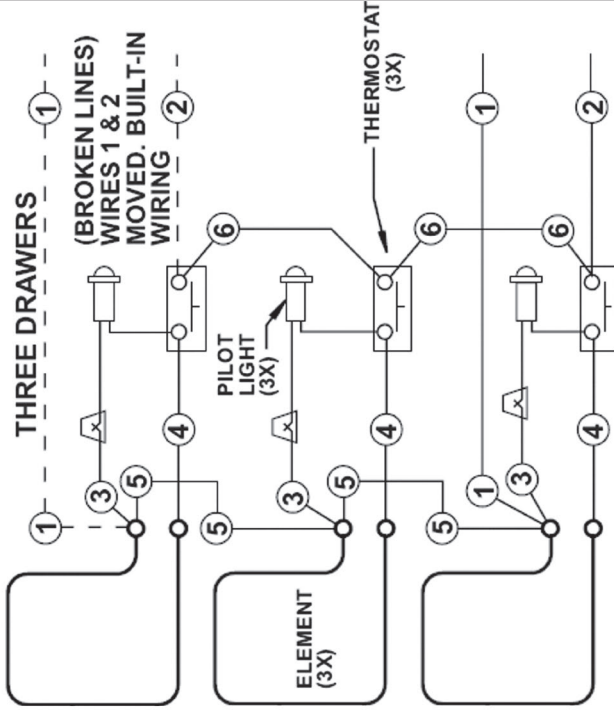

TWO DRAWERS

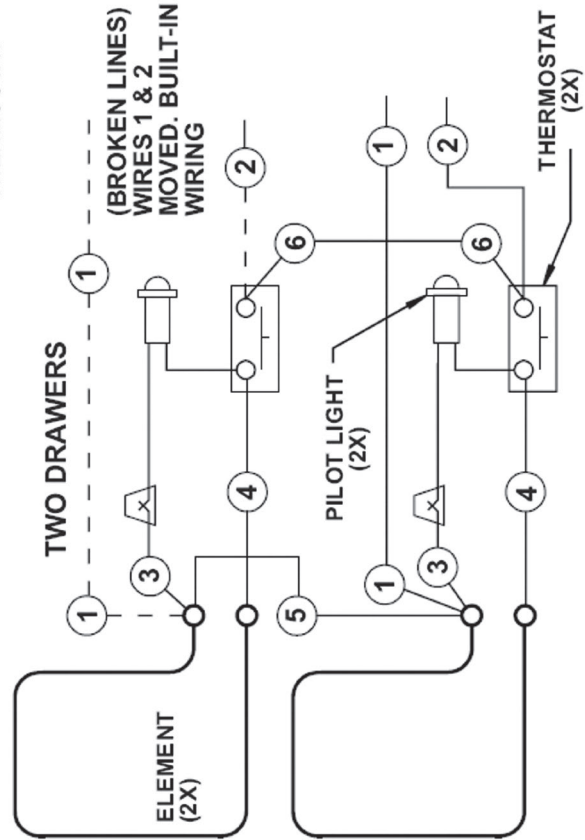

307640 (A)

EXPLODED VIEW & PARTS LIST: RW1HD, RW2HD, RW3HD

DRAWER ASSEMBLY - COMMON TO ALL HD VERSIONS

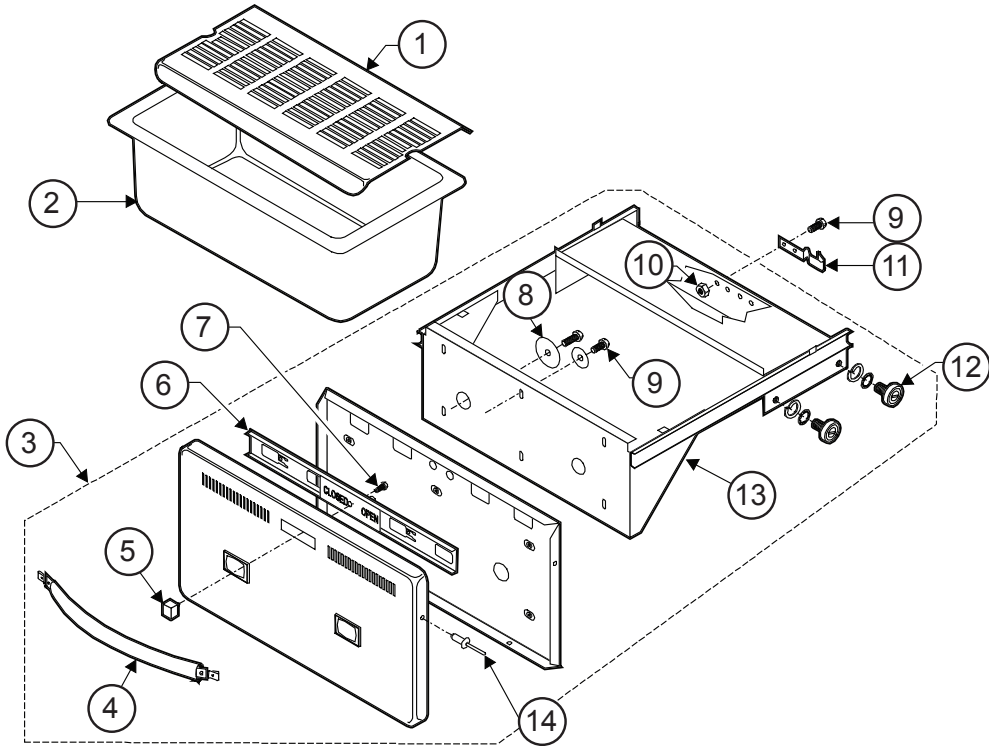

CAVITY and CABINET INERIOR - COMMON TO ALL HD VERSIONS

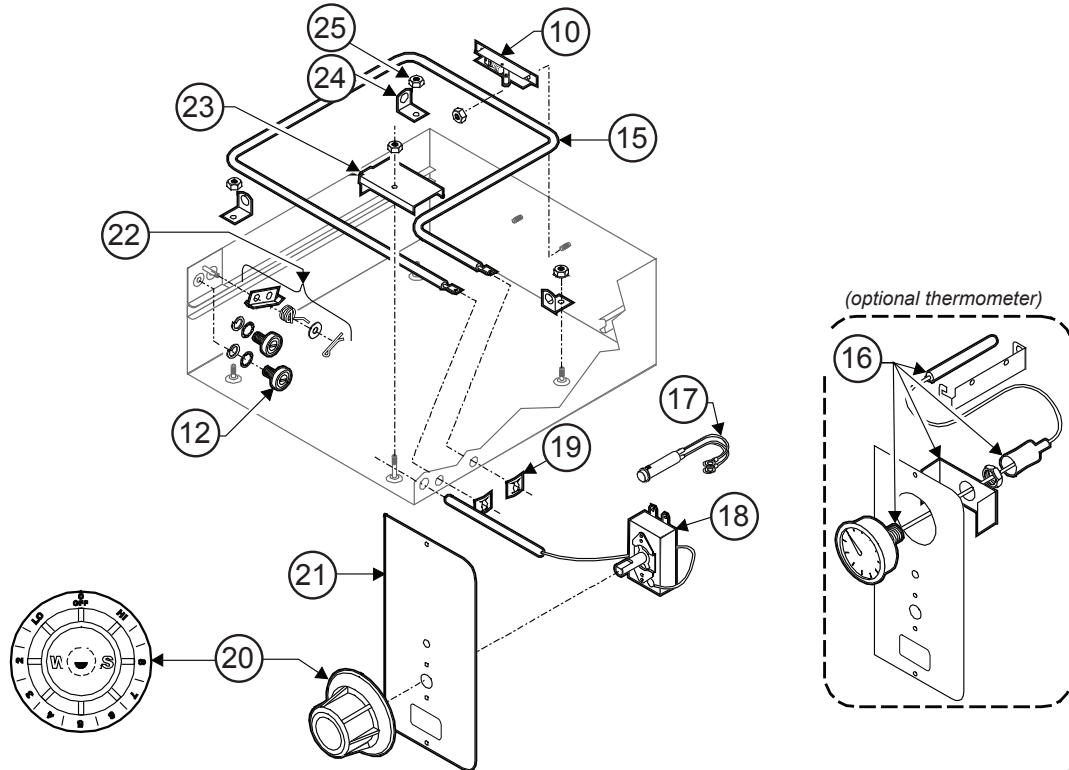

IL2251b

EXPLODED VIEW & PARTS LIST

RW1HD, RW2HD, RW3HD, DRAWER WARMER		
Fig No	Part No.	Description
1	WS-20624	RACK HUMITROL RWS (OPTIONAL)
2	C8-46840	PAN INSERT DRAWER RWHD
3	WS-67096	DRAWER ASSY KIT RWHD
4	C8-32112	HANDLE RW DRAWER SRW320
5	WS-51796	KNOB SQUARE ROLL WARMER VENT
6	C8-49251	SLIDE VENT ASSY RWN
7	2C-35530	SCREW, 8-32 X 3/8 PH, RD-EACH
8	2C-35565	WASHER 2 1/16 DRWR BACK
9	2C-35487	SCREW 8-32X5/16 PH TR HD
10	2C-35455	NUT 8-32 HEX MS SS
11	2C-30471	DRAWER STRIKE AND CATCH
12	2P-30483	BRNG RLLR TRK-R116
13	C8-45335	DRAWER WELD ASSY RWHD
14	2C-49395	RIVIT POP 1/8 X .265 SS
15	2N-30482UL	ELEM 240V 450V
	2N-30519UL	ELEM 120V 450W, ROLL WRMR
16	2T-44475	THERMOMETER RW 2IN DIAL
17	2J-35687	LT SGNL
18	WS-58936	THERMO CTL KIT RW W/O AUX
19	2C-43271	CLIP RETAINER PILOT LIGHT
20	2R-30372	KNOB CONTROL ASSY, WARMER
21	C8-Z12392	CONTROL PANEL
22	WS-65923	REPR KIT-DWR STOP W/ 6 COIL SPRING
	C8-507819	REPR KIT-DWR STOP W/ 3 COIL SPRING
23	C8-35683	SHIELD BULB RWS
24	C8-35677	ANGLE SUPPORT ELEM RWS
25	2C-35455	NUT 8-32 HEX MS SS
NI	2E-35540	CORD SET

EXPLODED VIEW & PARTS LIST: RWN1, RWN2, RWN3

DRAWER ASSEMBLY - COMMON TO ALL "NARROW" VERSION RWN-SERIES DRAWERS

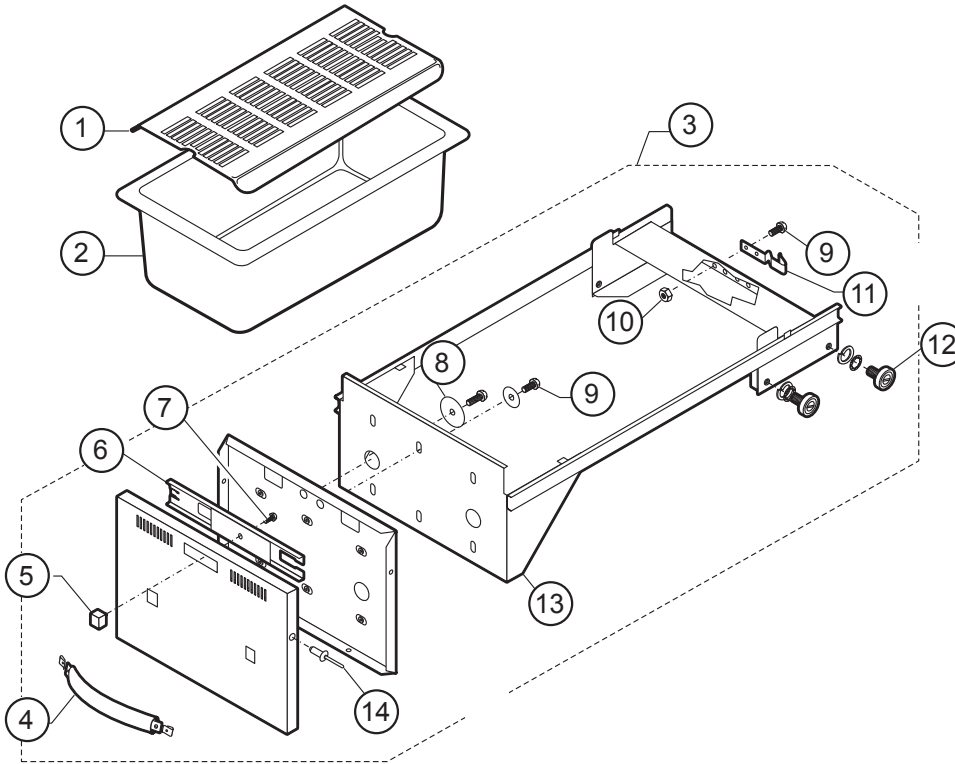

CAVITY and CABINET INTERIOR - COMMON TO ALL "NARROW" VERSION

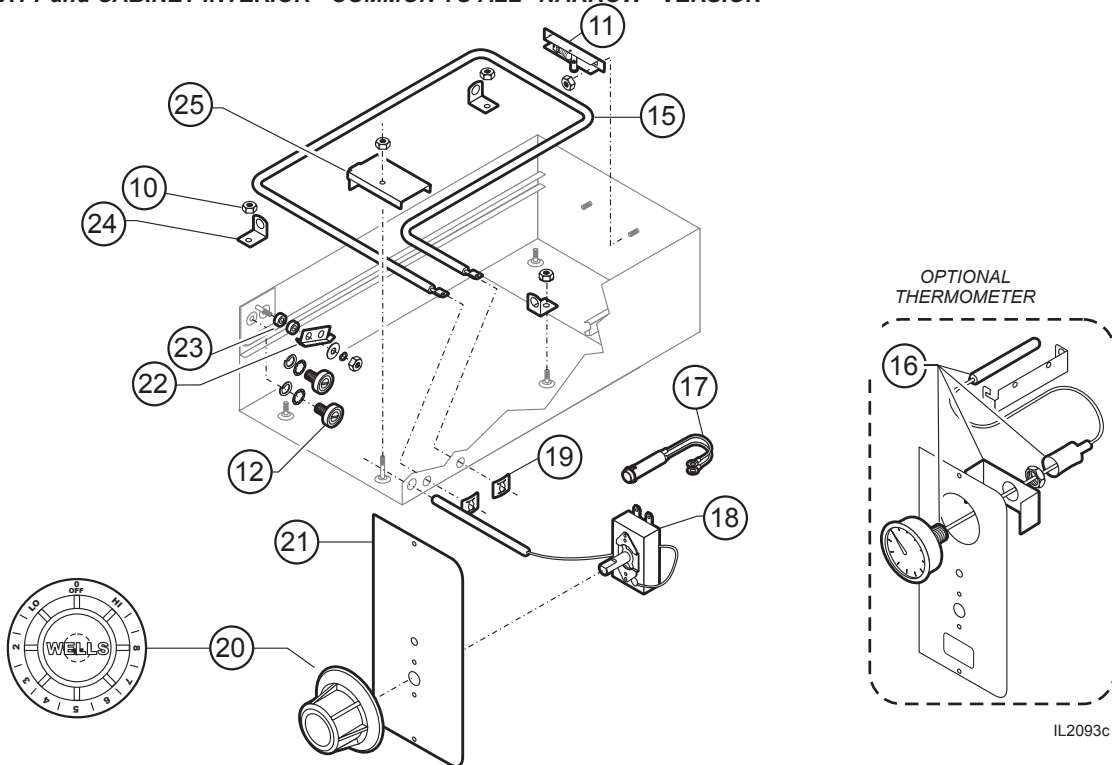

EXPLODED VIEW & PARTS LIST

RWN1, RWN2, RWN3, DRAWER WARMER		
Fig No	Part No.	Description
1	WS-20624	RACK HUMITROL RWS (OPTIONAL)
2	C8-49252	INSERT DRAWER RWN
3	WS-69244	DRAWER ASSY RWN
4	WS-69248	HANDLE DRWR RWN
5	WS-51796	KNOB SQUARE ROLL WARMER VENT
6	C8-49251	SLIDE VENT ASSY RWN
7	2C-35530	SCREW, 8-32 X 3/8 PH, RD-EACH
8	2C-35565	WASHER 2 1/16 DRWR BACK
9	2C-35487	SCREW 8-32X5/16 PH TR HD
10	2C-35455	NUT 8-32 HEX MS SS
11	2C-30471	DRAWER STRIKE AND CATCH
12	2P-30483	BRNG RLLR TRK-R116
13	WS-69244	DRAWER ASSY RWN
14	2C-49395	RIVIT POP 1/8 X .265 SS
15	2N-49255UL	ELEM 120V 450W RWN
	2N-49475UL	ELEM 240V 450W RWN
16	2T-44475	THERMOMETER RW 2IN DIAL
17	2J-35687	LT SGNL
18	WS-58936	THERMO CTL KIT RW W/O AUX
19	2C-43271	CLIP RETAINER PILOT LIGHT
20	2R-30372	KNOB CONTROL ASSY, WARMER
21	C8-Z12394	CONTROL PANEL
22	C8-35988	STOP DRWR RWS
23	2A-45405	SPACER DRWR STOP SS RWW
24	C8-35677	ANGLE SUPPORT ELEM RWS
25	C8-35683	SHIELD BULB RWS
NI	2E-35540	CORD SET

NOTES

PARTS & SERVICE

DESCRIPTION

PART NO.

HUMITROL RACK
 PAN, STAINLESS (ALL EXCEPT RWN)
 PAN, STAINLESS (RWN ONLY)

WS-20624
 C8-46840
 C8-49252

LEG KIT, 4" PLASTIC (SET OF 4)
 LEG KIT, 4" METAL (SET OF 4)
 LEG KIT, 6" METAL (SET OF 4)

WS-20314
 WS-20563
 WS-21607

CASTER KIT 10" HIGH (SET OF 4)
 CASTER KIT 3-1/2" HIGH (SET OF 4)
 CASTER KIT 2-1/4" HIGH (SET OF 4)

WS-21034
 WS-21947
 WS-22025

IMPORTANT: Use only factory authorized service parts and replacement filters.

For factory authorized service, or to order factory authorized replacement parts, contact your Wells authorized service agency, or call:

Wells Manufacturing
 10 Sunnen Dr.,
 St. Louis MO 63143 USA

Service Dept.
 phone: (314) 678-6314
 fax: (314) 781-2714

Service Parts Department can supply you with the name and telephone number of the WELLS AUTHORIZED SERVICE AGENCY nearest you.

CUSTOMER SERVICE DATA

Please have this information available if calling for service

RESTAURANT _____ LOCATION _____
 INSTALLATION DATE _____ TECHNICIAN _____
 SERVICE COMPANY _____
 ADDRESS _____ STATE _____ ZIP _____
 TELEPHONE NUMBER (____) _____ - _____

EQUIPMENT MODEL NO. _____

EQUIPMENT SERIAL NO. _____

VOLTAGE: (check one) 120 208 240



Wells Bloomfield proudly supports CFESA
Commercial Food Equipment Service Association

SERVICE TRAINING - QUALITY SERVICE



CUSTOMER SATISFACTION



WELLS MANUFACTURING
10 Sunnen Dr., St. Louis, MO 63143
telephone: 314-678-6314
fax: 314-781-2714
www.wellsbloomfield.com