



**WELLS MANUFACTURING**  
265 Hobson Street, Smithville, Tennessee  
37166 telephone: (800) 264-7827  
[www.wells-mfg.com](http://www.wells-mfg.com)



WV-2HGRW

**OWNER'S MANUAL**

**WV2HG SERIES**

**GRIDDLE / HOTPLATE  
COOKTOP  
with  
UNIVERSAL HOOD**

**MODELS:  
WV2HG  
WV2HGRW  
WV2HSG  
WV2HSGRW**

**Includes  
INSTALLATION  
USE & CARE EXPLODED  
VIEW PARTS LIST  
WIRING DIAGRAM**

**IMPORTANT: DO NOT DISCARD THIS MANUAL**

This manual is considered to be part of the appliance and is to be given to the OWNER or MANAGER of the restaurant, or to the person responsible for TRAINING OPERATORS of this appliance. Additional manuals are available from your WELLS DEALER.

**THIS MANUAL MUST BE READ AND UNDERSTOOD BY ALL PERSONS USING OR INSTALLING THIS APPLIANCE.** Contact your WELLS DEALER if you have any questions concerning installation, operation or maintenance of this equipment.

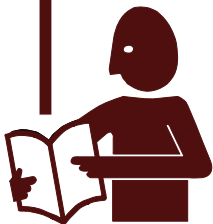

### LIMITED EQUIPMENT WARRANTY

Wells Manufacturing warrants to the original purchaser of new Wells products to be free from defects in material or workmanship, under normal and proper use and maintenance service as specified by Wells and upon proper installation and start-up in accordance with the instructions supplied with each Wells unit. Wells' obligation under this warranty is limited to a period of one [1] year from the date of original installation, or eighteen [18] months from original invoice date, whichever occurs first. Defects that occur as a result of normal use, within the time period and limitations defined in this warranty, will at Wells' discretion have the parts replaced or repaired by Wells or a Wells-authorized service agency.

### THIS WARRANTY IS SUBJECT TO ALL LISTED CONDITIONS

Repairs performed under this warranty are to be performed by a Wells authorized service agency. Wells will not be responsible for charges incurred or service performed by non-authorized repair agencies. In all cases, the nearest Wells-authorized service agency must be used. Wells will be responsible for normal labor charges incurred in the repair or replacement of a warranted product within 50 miles (80.5 km) of an authorized service agency. Time and expense charges for anything beyond that distance will be the responsibility of the owner. All labor will need to be performed during regular service hours. Any overtime premium will be charged to the owner. For all shipments outside the U.S.A. and Canada, please see the International Warranty for specific details. It is the responsibility of the owner to inspect and report any shipping damage claims, hidden or otherwise, promptly following delivery. No mileage or travel charges will be honored on any equipment that is deemed portable. In general, equipment with a cord and plug weighing less than 50 lb. (22.7 kg) is considered portable and should be taken or shipped to the closest authorized service agency, transportation prepaid.

### CONTACT

Should you require any assistance regarding the operation or maintenance of any Wells Manufacturing; phone or email our service department. In all correspondence provide the model number and serial number of the unit needing service; include the voltage or gas type.

Normal Business Hours: 8:00 a.m. to 4:30 p.m. Central

Telephone: 800-264-7827 Tech Service Option 2

Email: [TechService@partstown.com](mailto:TechService@partstown.com)

[www.Wells-Mfg.com](http://www.Wells-Mfg.com)

PRODUCTS	PARTS	LABOR
Universal Ventless Hoods (WVU)	1 year	1 year
Canopy Ventless Hoods (WVC)	1 year	1 year
"Cook and Hold" equipment (HW10, HWSMP, LLSC7, LLSC7WA, LLSC11, LLSC11WA)	1 years	1 year
Cast iron grates, burners and burner shields	1 year	
Original Wells parts sold to repair Wells Equipment	90 days	

### WARRANTY EXCLUSIONS

#### THE FOLLOWING WILL NOT BE COVERED UNDER WARRANTY.

Wells' sole obligation under this warranty is limited to either repair or replacement parts, subject to the additional limitations detailed below. This warranty neither assumes nor authorizes any person to assume obligations other than those expressly covered by this warranty.

- Any product which has not been used, maintained, or installed in accordance with the directions published in the appropriate installation sheet and/or owner's manual, including incorrect gas or electrical connection. Wells is not liable for any unit which has been mishandled, abused, misapplied, subjected to harsh chemicals, modified by unauthorized personnel, damaged by flood, fire, or other acts of nature [or God], or which have an altered or missing serial number.
- Installation, labor, and job checkouts, calibration of heat controls, air and gas burner/bypass/pilot adjustments, gas or electrical system checks, voltage and phase conversions, cleaning of equipment, or seasoning of griddle surface.
- Replacement of fuses or resetting of circuit breakers, safety controls, or reset buttons.
- Replacement of broken or damaged glass components, quartz heating elements, and light bulbs.
- Labor charges for all removable and consumable parts in gas charbroilers and hotplates, including but not limited to burners, grates, and radiants.
- Any labor charges incurred by delays, waiting time, or operating restrictions that hinder a service technician's ability to perform service.
- Replacement of parts that fail or are damaged due to normal wear or labor for replacement of parts that can be replaced during a daily cleaning routine, such as but not limited to silicone belts, PTFE non-stick sheets, control labels, knobs, bulbs, fuses, quartz heating elements, baskets, racks, and grease drawers.
- Any economic loss of business or profits.
- Non-OEM parts. Use of non-OEM parts without Wells' approval will void the warranty.
- Units exceeding one [1] year from original installation date, or more than eighteen [18] months from original invoice date, whichever comes first.

### ADDITIONAL WARRANTIES

- Specific/chain-specific equipment may have additional and/or extended warranties.

The foregoing warranty is in lieu of any and all other warranties expressed or implied and constitutes the entire warranty.

## TABLE OF CONTENTS

WARRANTY	
SPECIFICATIONS	1
FEATURES & OPERATING CONTROLS	2
PRECAUTIONS & GENERAL INFORMATION	6
AGENCY LISTING INFORMATION	8
INSTALLATION	9
OPERATION	14
CLEANING INSTRUCTIONS	18
MAINTENANCE INSTRUCTIONS	22
TROUBLESHOOTING SUGGESTIONS	23
MAINTENANCE SCHEDULES	24
MSDS (Ansulex Low pH)	27
ANSUL® COMPONENTS	29
EXPLODED VIEW & PARTS LIST	30
WIRING DIAGRAM	38
PARTS & SERVICE	41
CUSTOMER SERVICE DATA	41

## INTRODUCTION

Thank You for purchasing this Wells Bloomfield appliance.

Proper installation, professional operation and consistent maintenance of this appliance will ensure that it gives you the very best performance and a long, economical service life.

This manual contains the information needed to properly install this appliance, and to use and care for the appliance in a manner which will ensure its optimum performance.

## SPECIFICATIONS

MODEL	ROLL WARMER	VOLTS 50/60 Hz	3Ø AMPS			1Ø AMPS	WATTS	DIMENSIONS / POWER CORD
			L1	L2	L3			
WV2HFG	NO	208V	16	32	23	38	8,000	30-3/8" WIDE (42-3/8" wide including spacers) 79-1/8" HIGH 35-3/8" DEEP Power Cord (when provided): NEMA 15-60P
		240V	18	35	24	41	9,900	
WV2HFGRW	YES	208V	21	35	24	43	8,900	
		240V	23	38	24	46	11,100	
WV2HSG	NO	208V	19	32	26	42	8,675	
		240V	21	35	27	45	10,800	
WV2HSGRW	YES	208V	23	35	26	46	9,575	
		240V	26	38	27	50	12,000	

Minimum clearances required from unit to nearest combustible surface or object				
	BACK	SIDE	BOTTOM	TOP
inches	n/a	6	6	19
millimeters	n/a	152	152	483

# FEATURES & OPERATING CONTROLS

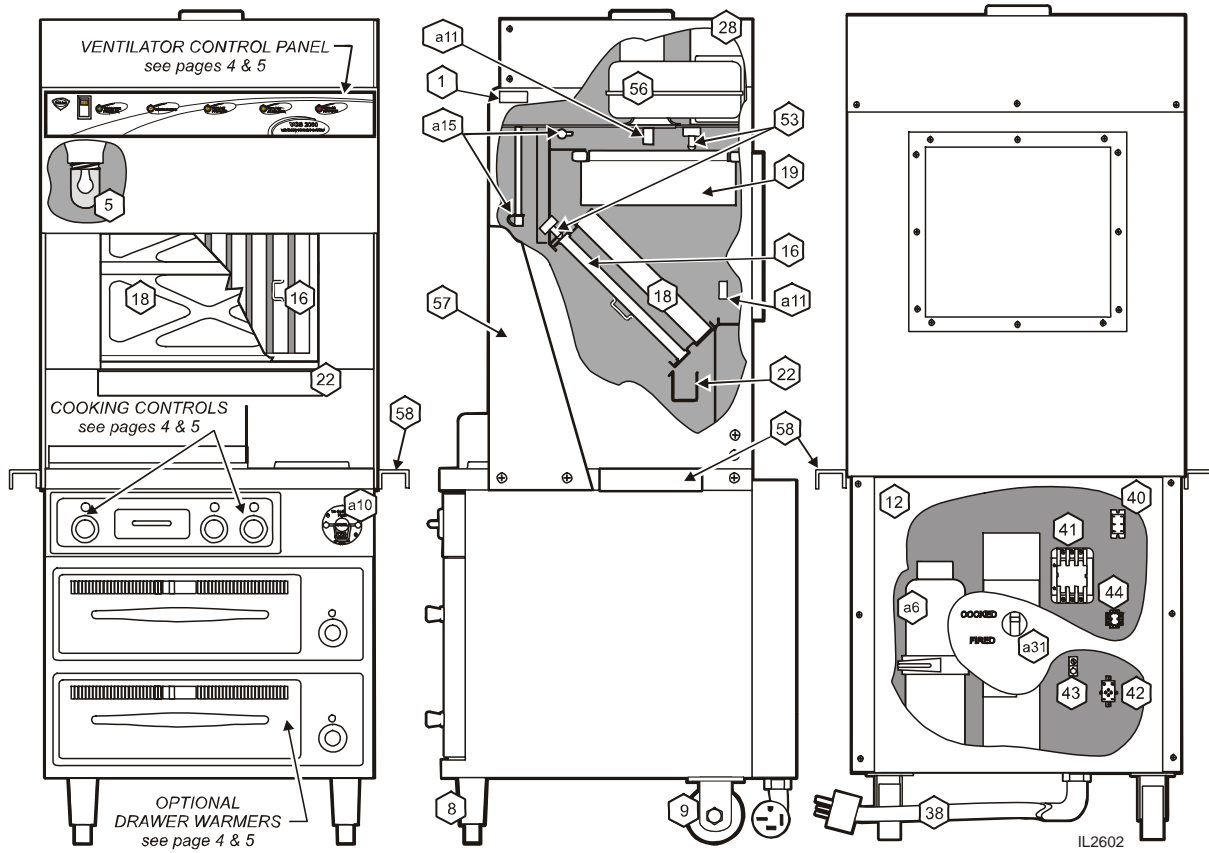

Fig. 1 Ventilator Section Operating Features & Controls

## FEATURES & OPERATING CONTROLS (continued)

VENTILATOR SECTION		
ITEM	DESCRIPTION	COMMENT
1	NAMEPLATE	Gives manufacturer, make and model description. Also lists voltage and amperage data.
5	APPLIANCE LIGHT	<i>ON</i> when hood power switch is <i>ON</i> . Illuminates cooktop.
a6.	FIRE SUPPRESSION AGENT TANK (1.5 gal.)	Container for Ansul <sup>TM</sup> Low-pH liquid fire suppression liquid.
8	ADJUSTABLE (FRONT) LEG	Allows the unit to be leveled.
9	RIGID (REAR) CASTER	Allows the unit to be easily positioned by lifting the front of the unit slightly.
a10.	MANUAL PULL STATION	Provides a means of manual activation of the fire suppression system. <b>PULL ONLY IN CASE OF FIRE!</b>
a11.	FUSIBLE LINKS	Designed to break at rated temperature. Breaking (i.e. fire on the cooktop) activates fire suppression system. Should be replaced at least once per year.
12	LOWER REAR ACCESS PANEL	Allows access to Ansul <sup>®</sup> fire suppression agent tank (a6) and controls also access to main power contactor (41).
a15.	DISCHARGE NOZZLE	Fire suppression media discharges here (2 places).
16	GREASE BAFFLE	Extracts and drains most grease and moisture from the air flow.
18	PRE-FILTER ASSEMBLY	Comprises the PRE-FILTER FRAME and a replaceable PRE-FILTER. Stops larger particles of grease from reaching the FILTER PACK for reduced maintenance costs.
19	HI-EFFICIENCY/CHARCOAL FILTER PACK	Stops most grease and smoke particles. Also assists in some cooking odor removal.
22	GREASE DRIP TRAY	Collects grease/moisture dripping from grease baffle(16).
28	VENTILATOR EXHAUST DUCT	Exit point for ventilator airflow - on top left rear of unit. <b>DO NOT BLOCK</b>
a31.	STATUS INDICATOR	Displays status of fire suppression system ( <i>COCKED - FIRED</i> ) If <i>FIRED</i> , a buzzer will sound continuously.
38	POWER CORD	6' cord and cap. Plug for NEMA 15-60R (receptacle by user).
41	POWER CONTACTOR	Energizes cooking appliances only while ventilator section is sensed as operational.
42	BUILDING FIRE ALARM RELAY	Reports fire alarm condition to building fire management system.
43	GROUND LUG	Ground wire of power cord connects here.
44	INTERLOCK TERMINAL	Provides connection for shut-down control by building fire management system.
53	FILTER INTERLOCK SWITCHES	Proper installation of grease baffle and filter pack close these switches in ventilator sensor circuit.
56	VENTILATOR FAN	Provides air movement for ventilation.
57	HOOD SIDE SHIELD	Required on left and right sides of hood. Factory installed.
58	SIDE SPACERS	Required to maintain 6" spacing from combustibles. Field installed

## FEATURES & OPERATING CONTROLS (continued)

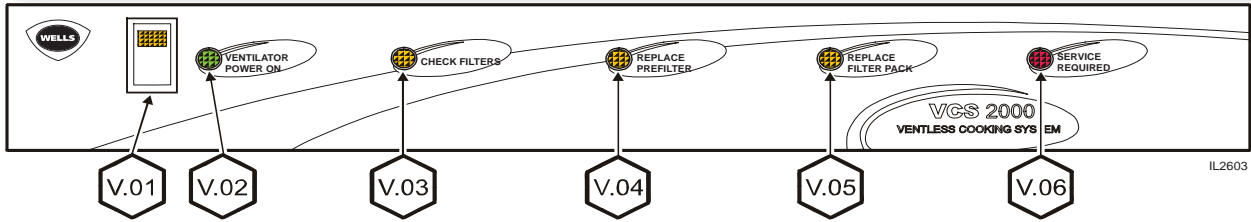

Fig. 2 Ventilator Section Controls & Indicator Lights

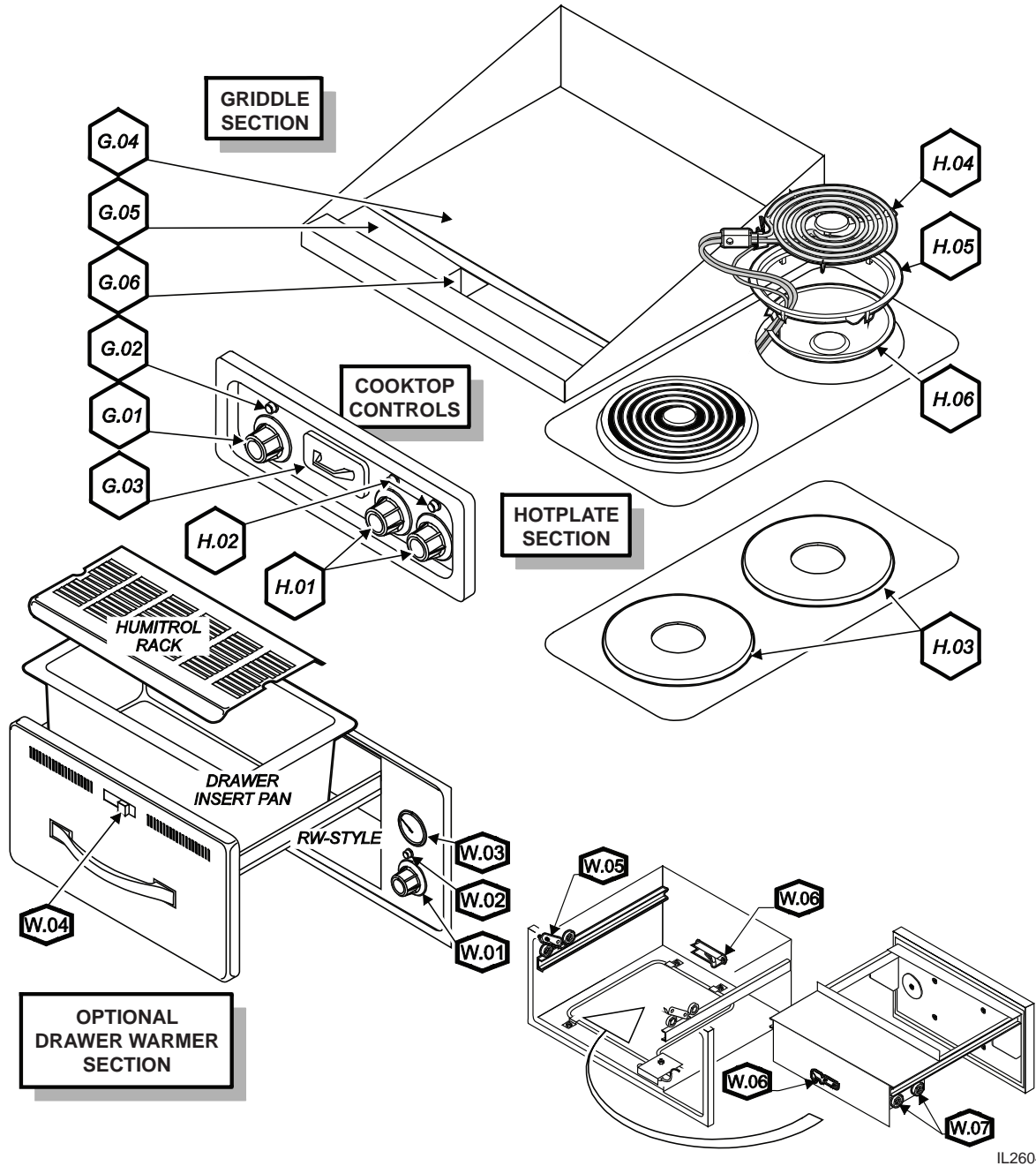

Fig. 3 Griddle, Hotplate and Drawer Warmer Sections

## FEATURES & OPERATING CONTROLS (continued)

FEATURES & OPERATING CONTROLS (continued)		
ITEM	DESCRIPTION	COMMENT
<b>VENTILATOR SECTION CONTROLS</b>		
V.01	POWER SWITCH	Energizes blower motor. If, after 10 seconds, proper conditions are met, cooking appliances are energized. Appliance light is <i>ON</i> when POWER SWITCH is <i>ON</i> .
V.02	<i>POWER ON</i> INDICATOR	GREEN. Glows when POWER switch is <i>ON</i> .
V.03	<i>CHECK FILTERS</i> ALARM INDICATOR	AMBER. Glows if one or more filters are out of position. Check all filters and baffles for proper installation.
V.04*	<i>REPLACE PREFILTER</i> ALARM INDICATOR	AMBER. Glows when PREFILTER is approaching the end of its service life and must soon be replaced.
V.05*	<i>REPLACE FILTER PACK</i> ALARM INDICATOR	AMBER. Glows when FILTER PACK is approaching the end of its service life and must soon be replaced.
V.06*	<i>SERVICE REQUIRED</i> ALARM INDICATOR	RED. Glows when PREFILTER and/or FILTER PACK has reached the end of its service life and is too loaded to allow sufficient air flow. Filter <b>MUST</b> be replaced. Appliance is <b>SHUT DOWN</b> until expended filters are replaced.
* See PRECAUTIONS & GENERAL INFORMATION, pages 8 for special procedures regarding prefilters and filter packs.		
<b>GRIDDLE SECTION</b>		
G.01	GRIDDLE TEMPERATURE CONTROL	Thermostatic control of griddle temperature
G.02	GRIDDLE HEAT INDICATOR	Glows when heating elements are energized.
G.03	GREASE DRAWER	Collects cooking waste from GRIDDLE. Removable for cleaning.
G.04	COOKING SURFACE	Heated portion for cooking food.
G.05	WASTE TROUGH	Scrape cooking waste to this area.
G.06	WASTE CHUTE	Cooking waste moved into GREASE DRAWER thru this opening.
<b>HOTPLATE SECTION</b>		
H.01	TEMPERATURE CONTROLS	Individual infinite switch control of the hotplate HEATING ELEMENTS
H.02	POWER INDICATOR	Glows anytime the TEMPERATURE CONTROL is in any position other than <i>OFF</i> .
H.03	SOLID HEATING ELEMENTS	WV2HG heating/cooking portion. Element is fixed in position.
H.04	SPIRAL HEATING ELEMENT	WV2SHG heating/cooking portion. Element lifts out for cleaning.
H.05	TRIM RING	Mounts element to cabinet.
H.06	DRIP PAN	Catches drippings and crumbs (spiral element only). Removable for cleaning.
<b>OPTIONAL DRAWER WARMER SECTION</b>		
W.01	WARMER TEMP CONTROL	Infinite switch control of temperature of one warmer drawer.
W.02	POWER ON INDICATOR	AMBER. Glows when associated temperature control is turned <i>ON</i> .
W.03	THERMOMETER (optional)	Reads temperature inside drawer cavity. Must be ordered at time of initial build.
W.04	HUMIDITY CONTROL	Slide control of shutters to control air circulation within the warmer drawer.
W.05	DRAWER CATCH	Holds drawer closed.
W.06	DRAWER STOP	Prevents drawer from opening too far. Spring loaded to permit easy removal of drawer.
W.07	DRAWER ROLLERS	Support drawer and allow it to open and close smoothly.

## PRECAUTIONS AND GENERAL INFORMATION



The FIRE SUPPRESSION SYSTEM MUST BE CHARGED AND CERTIFIED BY AN AUTHORIZED ANSUL® DISTRIBUTOR. NEVER ATTEMPT TO MODIFY OR BYPASS THE FIRE SUPPRESSION SYSTEM.

AN UNCONTROLLED FIRE CAN CAUSE SERIOUS INJURY, DEATH AND/OR PROPERTY LOSS.



All servicing requiring access to non-insulated electrical components must be performed by a factory authorized technician.

DO NOT open any access panel which requires the use of tools. Failure to follow this warning can result in severe electrical shock.

NOTE: Fire suppression system and all associated components must only be serviced by an authorized Ansul® Distributor. All setup, charging, repair and/or adjustment of the fire suppression system must be performed by an Authorized Ansul® Distributor ONLY.

IMPORTANT: If a remote pull station is installed, both rear casters (9) must be replaced with legs to deter moving the unit. MOVING AN APPLIANCE WITH A REMOTE PULL STATION WILL DISCHARGE THE FIRE SUPPRESSION SYSTEM.

This Ventless Cooking System™ is designed to help reduce odor emissions, but will not completely eliminate cooking odors. Air exchange at the installation site must comply with the requirements of the local jurisdictional authority. To ensure that odors do not build-up, recommended minimum air exchange is 300 - 400 cfm of outside air into and out of the area where the unit is used. Recommend use of wall fan and wall switch, to be supplied by user.

Disconnect this appliance from electrical power before performing any maintenance or servicing.

Any procedure which requires the use of tools must be performed by a qualified technician.

This appliance is not jet stream approved. Do not direct water jet or steam jet at this appliance, or at any control panel or wiring.

Do not splash or pour water on, in or over any exposed element, control, control panel or wiring.

The surface of the griddle is very hot during operation and can cause severe burns. Avoid contact with the hot griddle surface.

Exposed surfaces of this appliance can be hot to the touch and may cause burns.

## PRECAUTIONS AND GENERAL INFORMATION (continued)

This appliance is intended for use in commercial establishments only.

This appliance is intended to prepare food for human consumption. No other use is recommended or authorized by the manufacturer or its agents.

Operators of this appliance must be familiar with the appliance use, limitations and associated restrictions. Operating instructions must be read and understood by all persons using or installing this appliance.

Cleanliness of this appliance is essential to good sanitation. Read and follow all included cleaning instructions and schedules to ensure the safety of the food product.

DO NOT submerge pre-filter or filter pack in water. Water will destroy the filters leading to equipment shut-down.

Use only genuine Wells replacement parts and filters, call (800) 264-7827 or your authorized Wells service agent. Parts supplied by others will void your warranty and may not provide safe operation.

The technical content of this manual, including any wiring diagrams, schematics, parts breakdown illustrations and/or adjustment procedures, is intended for use by qualified technical personnel.

This manual is considered to be a permanent part of the appliance. This manual and all supplied instructions, diagrams, schematics, parts breakdown illustrations, notices and labels must remain with the appliance if it is sold or moved to another location.

This appliance is made in the USA. Unless otherwise noted, this appliance has American sizes on all hardware.



### CAUTION: RISK OF DAMAGE

DO NOT connect or energize this appliance until all installation instructions are read and followed. Damage to the appliance will result if these instructions are not followed.



### CAUTION: Hot Surface

Exposed surfaces can be hot to the touch and may cause burns.

## PRECAUTIONS AND GENERAL INFORMATION (continued)

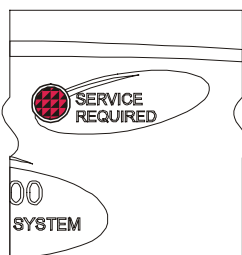
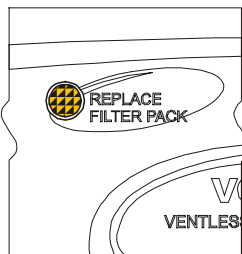
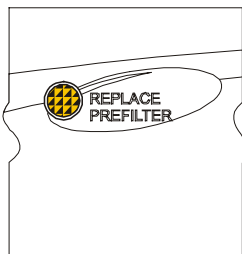

Fig. 4 Ventilator Warning Indicators

### OPERATIONAL NOTES:

*REPLACE PREFILTER* and *REPLACE FILTER PACK* indicator lights provide a timely warning that a system shut-down is imminent.

The actual time between the indicator light coming on and the loss of cooking appliance power will depend upon the cooking conditions.

Anytime a dirty pre-filter is replaced, the system airflow will increase. If the condition of the FILTER PACK is marginal, the *REPLACE FILTER PACK* light could then come on. If this happens, a fresh FILTER PACK must be installed within a reasonably short time.

Loss of airflow through the old filter pack will soon cause a system shut-down when the airflow falls below minimum vapor capture levels.

### **KEEP SPARE FILTER PACKS ON HAND.**

**IMPORTANT:** If you decide to “get the most” out of the old filter pack, and continue to use it until a system shut-down happens, it is advisable to have a fresh filter pack readily at hand, and have someone available who is capable of replacing it. Otherwise, you may experience an extended down time, with consequent associated loss of business.

**The manufacturer assumes no liability for loss of business due to a system shutdown caused by a dirty pre-filter and/or filter pack (i.e. red SERVICE REQUIRED light is on), when the user fails to have the proper replacement pre-filter and/or filter pack on hand.**

The Ventless Cooking System™ hood is designed as part of a **WELLS cooking appliance** only. No other use of this product is authorized by the manufacturer or its agents. Wells Mfg. assumes no liability for the use of this equipment with products by any other manufacturer's, or for use of this equipment with any Wells Manufacturing product other than in factory certified applications.

## AGENCY LISTING INFORMATION



STD 4



E146882



E146882

This appliance conforms to NSF Standard 4 for sanitation only if installed in accordance with the supplied Installation Instructions and operated and maintained in accordance with the instructions in this manual.

This appliance is



and Listed under UL File E146882.

## INSTALLATION

### UNPACKING & INSPECTION

Carefully remove the appliance from the carton. Remove all protective plastic film, packing materials and accessories from the Appliance before connecting electrical power or otherwise performing any installation procedure.

Carefully read all instructions in this manual and the Installation Instruction Sheet packed with the appliance before starting any installation.

Read and understand all labels and diagrams attached to the appliance.

Carefully account for all components and accessories before discarding packing materials. Store these components in or near the appliance for later use. These items must be installed before operating the appliance.

- 1 ea. FIRE SUPPRESSION AGENT (ANSULEX® Low pH, 1.5 GAL.)  
See Material Safety Data Sheet, page 28.
- 1 ea. FIRE SUPPRESSION MEDIA TANK
- 1 ea. FIRE SUPPRESSION TANK CHARGING CARTRIDGE
- 1 ea. GREASE BAFFLE
- 1 ea. FILTER PACK ASSEMBLY
- 1 ea. PRE-FILTER HOLDER with PRE-FILTER
- 1 ea. GREASE DRIP TRAY
- 1 ea. GREASE DRAWER ASSY FOR GRIDDLE
- 2 ea. 6" SIDE SPACERS
- 1 ea. LITERATURE PACKAGE

Additionally:

- 2 ea. DRAWER PANS (if unit has optional drawer warmers)
- 2 ea. HUMITROL RACKS (if ordered with warmer drawers)

### SETUP

Setup the appliance only on a firm level surface. Non-combustible material is recommended.

Refer to the Installation Instruction Sheet for required clearances. Maintain required clearances between the appliance and adjacent combustible surfaces. Verify 6" left and right side clearances to combustible construction. This appliance requires a minimum of 8 ft (96") (floor to overhead) to allow for adequate exhaust.

**IMPORTANT:** Provided 6" side spacers (item 58) must be installed on the appliance.

Factory installed side shields (item 57) are required.

Verify that the VENTILATOR HOOD ASSEMBLY is properly and securely assembled to the cooking appliance before beginning the installation procedure.

If a remote manual pull station is to be installed, replace the rear casters with legs.

Level the unit after it is in its final position. Using a spirit level, verify that the unit is level front-to-back and side-to-side.

NOTE: DO NOT discard the carton or other packing materials until you have inspected the appliance for hidden damage and tested it for proper operation.

Refer to SHIPPING DAMAGE CLAIM PROCEDURE on the inside front cover of this manual.



### WARNING: Risk of injury

Installation procedures must be performed by a qualified technician with full knowledge of all applicable electrical codes. Failure can result in personal injury and property damage.



### WARNING: FIRE HAZARD

Avoid storing flammable or combustible materials near the appliance.

## INSTALLATION (continued)

### IMPORTANT!

Verify that this VENTILATOR and food cooking equipment installation is in compliance with the specifications listed in this manual, with local code requirements, and in accordance with N.F.P.A 96 (*THE STANDARD FOR VENTILATION CONTROL AND FIRE PROTECTION OF COMMERCIAL COOKING OPERATIONS* - current edition).

**THIS IS THE  
RESPONSIBILITY  
OF THE INSTALLER.**



### DANGER ELECTRIC SHOCK HAZARD

ELECTRIC CONNECTIONS  
MUST BE MADE BY A  
LICENSED ELECTRICIAN

Electrical shock will cause  
death or serious injury.



### CAUTION: ELECTRICAL SHOCK HAZARD

The ground lug of this  
appliance must be connected  
to a suitable building ground.  
NOTE: This appliance  
requires a dedicated 60  
Amp electrical branch circuit  
protection.

### IMPORTANT:

Contact a licensed electrician  
to install and connect  
electrical power to the  
appliance.

### IMPORTANT:

Damage due to being  
connected to the wrong  
voltage or phase is NOT  
covered by warranty.

### SERVICE TECHNICIAN INSTALLATION NOTES

An Ansul® technician must charge and arm the fire suppression system before the ventilator blower will operate. See page 11.

Installation and start up must be performed by an Authorized Installation Company.

Installer must complete the *WARRANTY REGISTRATION* form, and record appliance installation particulars on the *CUSTOMER SERVICE DATA* form in this manual.

Certain codes require cooking equipment to be restrained with a RESTRAINT DEVICE. It is the RESPONSIBILITY OF THE INSTALLER to check with the authority having jurisdiction, in order to ascertain the applicability of this requirement to this specific EQUIPMENT installation. Any restraint device must allow access to the back and sides of the unit to provide for servicing and maintenance, and must not interfere with the operation of the FIRE SUPPRESSION SYSTEM.

### ELECTRICAL INSTALLATION

1. This appliance must be installed by a licensed electrician in accordance with all applicable codes and ordinances. Electrical connection terminal block and ground lug are accessible by removing the right side panel.
2. Refer to the nameplate on the right side of the appliance. Verify the ELECTRICAL SERVICE POWER. Voltage and phase must match the nameplate specifications, and available electrical service amperage must meet or exceed the specifications listed on page 1. Wiring must be no less than 6 AWG solid copper wire, rated for at least 90°C.

**NOTE:** Wire gauge, insulation type and temperature rating, as well as type, size and construction of conduit, must meet or exceed applicable specifications of local codes and of the National Electrical Code.

**NOTE:** This appliance requires a NEMA 15-60R receptacle.

3. This appliance must be connected to a suitable building ground. The equipment ground connection is marked “”.
4. The appliance is shipped from the factory wired for 3Ø electrical service. Refer to the Wiring Diagram included with this appliance, and verify that field wiring conforms to this diagram.

**IMPORTANT:** This appliance is not approved for 1Ø operation. Conversion of this appliance to single-phase operation will void the warranty.

## INSTALLATION (continued)

### FIRE SUPPRESSION SYSTEM INSTALLATION

1. Any REMOTE MANUAL PULL STATION must be installed by an authorized ANSUL® distributor in accordance with the Authority Having Jurisdiction.

**NOTE:** If a REMOTE MANUAL PULL STATION is installed, moving the unit for servicing will cause the Ansul® system to discharge. In this case, the unit must only be installed with four fixed legs (i.e. remove rear casters and replace with legs). Additional legs may be ordered through an Authorized Wells Service Agency. See page 29.

2. The FIRE SUPPRESSION SYSTEM is comprised of a pressurized cartridge & container of liquid fire suppressant, with associated plumbing and controls. It utilizes factory installed FUSIBLE LINKS for automatic actuation, and a factory installed MANUAL PULL STATION for manual actuation. Two NOZZLES are used to disperse the liquid fire suppression media.

3. When the fire suppression system activates, the fire suppression media is discharged, both the cooking appliance and the ventilator are de-energized, and a buzzer will sound continuously. The fire suppression media will form an emulsion designed to both smother and cool the fire.

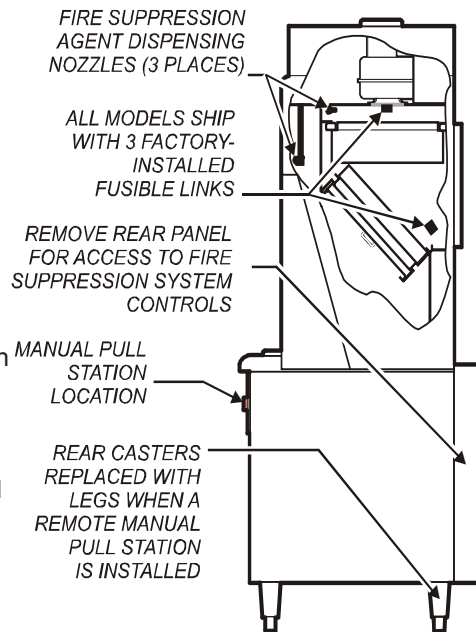

Fig. 5 Fire Suppression System

**Call your Authorized Ansul® Distributor immediately for service.**

**NOTE:** See page 24 for the Material Safety Data Sheet for the fire suppression agent.

4. The MANUAL PULL STATION and any similar REMOTE MANUAL PULL STATION will activate the fire suppression system when the ring on the pull station is pulled horizontally.

**DANGER**  
**DANGER**  
**FIRE**  
**HAZARD**



The FIRE SUPPRESSION SYSTEM MUST BE CHARGED AND CERTIFIED BY AN AUTHORIZED ANSUL® DISTRIBUTOR. NEVER ATTEMPT TO MODIFY OR BYPASS THE FIRE SUPPRESSION SYSTEM.

AN UNCONTROLLED FIRE CAN CAUSE SERIOUS INJURY, DEATH AND/OR PROPERTY LOSS.

**IMPORTANT:** The FIRE SUPPRESSION SYSTEM must be set-up and charged by an authorized **Ansul®** distributor before the ventilator blower will operate.

**NOTE:** If the fire suppression system is discharged, a buzzer will sound continuously and the cooking appliance will remain inoperable until the fire suppression system is serviced. **Recharging and resetting must be performed by an authorized Ansul® distributor ONLY.**

Charging of the Ansul Fire Suppression system must be in accordance with Ansul® Design, Installation, Recharge and Maintenance Manual. (Ansul® #418087-05)

## INSTALLATION (continued)

### NOTE:

The GREASE BAFFLE and FILTER PACK activate mechanical switches, and the PRE-FILTER activates a vacuum switch, to verify that the filter elements are in their proper positions. All filter elements must be properly installed or the cooking appliances will not be energized. Also, the CHECK FILTERS indicator will light.

### IMPORTANT:

The filter hook prevents the pre-filter from being drawn in during operation. After installation, press against the top of the filter frame to verify proper engagement of the filter hook over the lip of the top filter rail.

Use only genuine Wells replacement parts and filters, call (800) 264-7827 or your authorized Wells service agent. Parts supplied by others will void your warranty and may not provide safe operation.

### FILTERS INSTALLATION

1. **FILTER PACK:** Ships installed in the hood. If the filter pack is not in position, the CHECK FILTERS indicator will light. If the FILTER PACK becomes clogged, the *REPLACE FILTER PACK* indicator will glow.

To install the FILTER PACK: Position the filter pack with the charcoal portion UP. Slide the filter pack toward the rear of the unit until it contacts the guides on the back panel. Push the filter pack UP into the upper opening until it rests firmly against the filter pack seal. When up in position, holder clips can be snapped over wall ledge on each side. To remove FILTER PACK: Grasp both holder clips and pull inward until the clips clear the sidewall ledge. Then, pull the filter pack down and out.

2. **PRE-FILTER:** The PRE-FILTER ships in the FILTER FRAME. If the PRE-filter is not in position, or if the PRE-FILTER is not in the FILTER FRAME, the CHECK FILTERS indicator will light. If the PRE-FILTER becomes clogged, the *REPLACE PRE-FILTER* indicator will glow.

To install the PRE-FILTER: Pay attention to the air flow markings. The AIR FLOW arrow will point away from the installer. Slide the assembly up into the front opening, behind the upper filter rail. While pressing slightly against the bottom of the assembly, pull the FILTER HANDLE toward you so as to engage the FILTER HOOK over the lip of the top filter rail. Then lower and seat the assembly into the top indentation of the lower filter rail.

3. **GREASE BAFFLE:** If the GREASE BAFFLE is not in place, the CHECK FILTERS indicator will glow.

To install the GREASE BAFFLE: Slide the grease baffle up into the indentation of the upper filter rail, then lower and seat it into the bottom indentation of the lower filter rail. Pull toward you and downward to verify the GREASE BAFFLE is properly seated in the lower frame rail.

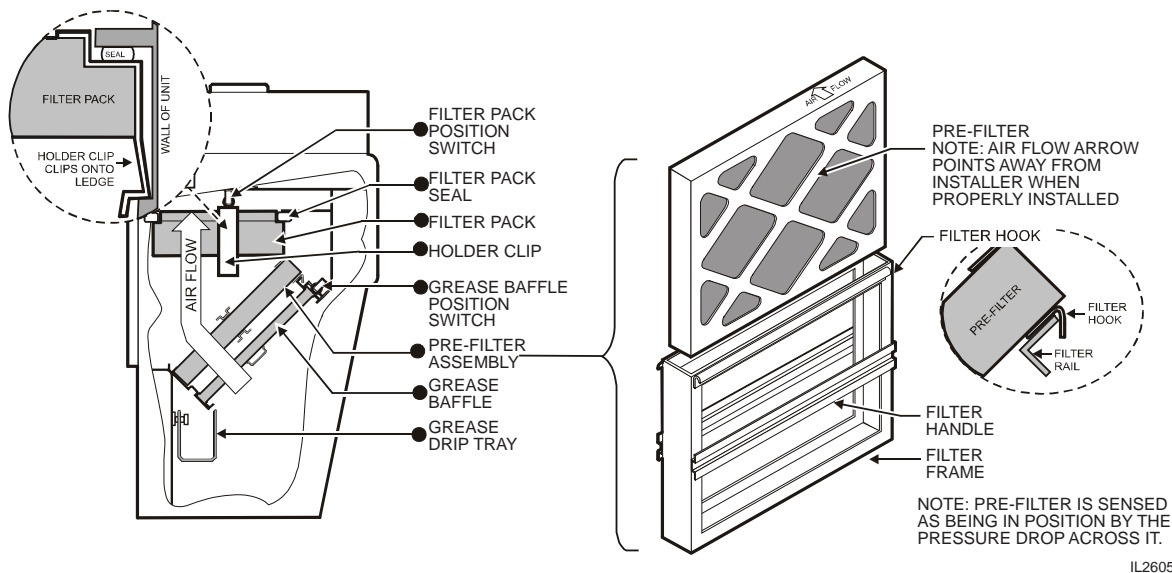

Fig. 6 Filter Installation

## INSTALLATION (continued)

### GREASE DRIP TRAY INSTALLATION

1. Install the GREASE DRIP TRAY on the hanger brackets, directly below the grease baffle.

### ROLL WARMER DRAWER INSTALLATION

1. Be sure roller catches (inside warmer cavity) are in the open position. Install drawer assemblies in drawer slides.
2. Place appropriate one drawer insert pan into each warmer drawer. If used, place one Humitrol rack into each drawer pan.

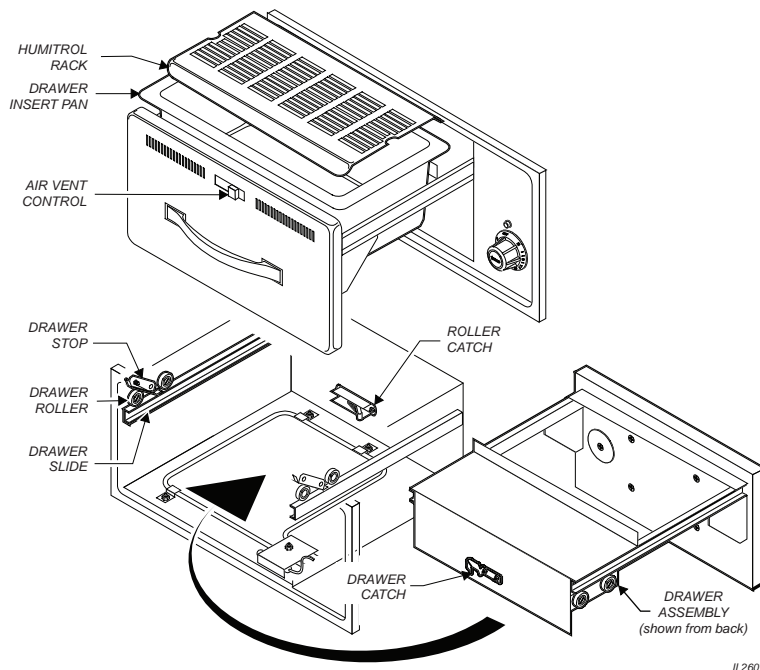

Fig. 7 Roll Warmer Drawer Pan Installation



**CAUTION:**  
**Burn Hazard**

DO NOT OPERATE UNLESS  
THE GREASE DRIP TRAY  
IS INSTALLED.



Moisture will drip into the hot cooking surface causing splattering of hot liquids. Serious injury can result from contact with hot splatter.

## OPERATION



### CAUTION: Hot Surface

Exposed surfaces can be hot to the touch and may cause burns.

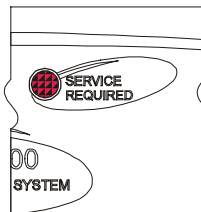
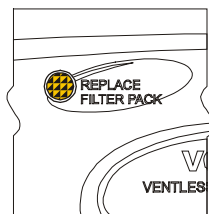
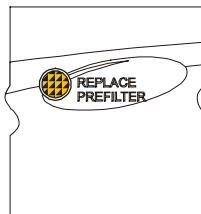
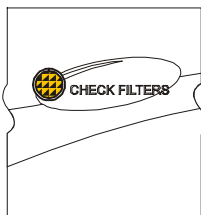
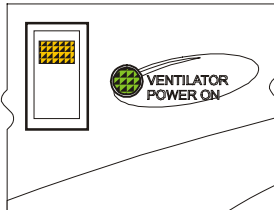

Fig. 8 Ventilator Indicator and Warning Lights

### VENTILATOR OPERATION

1. Press the VENTILATOR POWER switch to ON. The green VENTILATOR POWER light will glow and the blower fan will start. After a short time, if all filters are sensed as being in position and not clogged, the cooking appliance will be energized. During normal operation, the VENTILATOR POWER light will be the only light glowing on the upper control panel.
2. If the amber CHECK FILTER light glows, one or more filter elements is out of position. Check the GREASE BAFFLE, PRE-FILTER and FILTER PACK for proper installation in their respective positions. Grease baffle and filter pack position are sensed by mechanical switches. Pre-filter position is sensed by a vacuum switch.
3. When the amber REPLACE PRE-FILTER light glows, the pre-filter is nearing the end of its service life. Replace the disposable PRE-FILTER ELEMENT.
4. When the amber REPLACE FILTER PACK light illuminates, the HEPA / Charcoal filter pack is nearing the end of its service life. Replace the filter pack.

**Note:** The REPLACE PRE-FILTER and REPLACE FILTER PACK lights are a warning that the indicated filter is near the end of its service life. The appliance will continue to operate for a period of time after the light glows to allow continued operation through a peak period. However, the indicated filters must be replaced within a reasonably short time period or they will clog and shut down electrical power to the cooking appliance. The ventilator blower will continue to run.

5. When the red SERVICE REQUIRED light glows, either the pre-filter or filter pack (or both) is clogged and can no longer pass sufficient air to allow further operation. The ventilator fan continues to run, but the cooking appliance is shut down until the underlying clogged filter situation has been corrected. This can occur when neither CHANGE... FILTER indicator light is lit, if both pre-filter and filter pack are marginal. Replacing both the pre-filter and the filter pack will remedy the situation.

**Note:** Replacing the pre-filter, even though not very dirty, will often extend the service life of the more expensive filter pack.

Reset the unit by turning the VENTILATOR POWER switch to OFF, then back ON.

6. A failure of incoming electrical power will cause a shut down of the unit. After power is restored, reset the unit by turning the VENTILATOR POWER switch to OFF, then back ON.

**NOTE:** Griddle and fryer will not operate unless the fire suppression system is charged, and the ventilator section is operating.

## OPERATION (continued)

### GRIDDLE OPERATION

#### PREPARING THE GRIDDLE SURFACE

##### 1. SEASONING STANDARD GRIDDLES

As manufactured, the steel surface of your Wells griddle has microscopic pores. It is important to fill these pores with oil in order to provide a hard, non-stick cooking surface.

- a. Preheat the griddle surface to 375°F (191°C).
- b. Spread a light film of cooking oil over the entire griddle surface
- c. Allow the oil film to cook in for approximately 2 minutes, or until it smokes.
- d. Wipe the griddle surface with a clean damp cloth until all oil is removed.
- e. For new griddles, repeat this procedure 2-3 times until the griddle has a slick, clean surface.

##### 2. CHROME PLATED GRIDDLES

Because the microscopic pores in the griddle surface are filled by the chrome plating, no seasoning of the griddle surface is required.

- a. Thoroughly clean the griddle surface using a soft clean cloth and a small amount of mild detergent.
- b. Rinse and dry thoroughly after cleaning.
- c. The griddle is now ready to use.

#### USING THE GRIDDLE

1. Turn the temperature control knob to the desired temperature. The indicator light will glow while the griddle is heating. When the indicator light first goes out, the griddle is ready to use.
2. For standard griddles, keep the griddle surface clean and well oiled during use. Scrape cooking waste into the grease tray frequently during use. Occasionally brush or spray a light coat of cooking oil on the griddle surface in order to maintain the non-stick surface.
3. For chrome plated griddles, scrape cooking waste into the grease tray after preparing each order.

DO NOT bang or tap pots, pans, spatulas or other metal utensils on the griddle surface as this may damage the chrome plating.



#### CAUTION: Hot Surface

Exposed surfaces can be hot to the touch and may cause burns.

#### NOTE:

Standard griddles must be seasoned after every cleaning.

#### IMPORTANT:

FOR CHROMED GRIDDLES, SCRATCHES WILL DAMAGE THE GRIDDLE SURFACE!

DO NOT use anything on this griddle that could scratch the surface.

DO NOT clean chrome surface with griddle bricks, pumice stone or abrasive cleansers.

DO NOT bang or tap pots, pans, spatulas or other metal utensils on the griddle surface as this may damage the chrome plating.

## OPERATION (continued)



### CAUTION: HOT SURFACE

Exposed surfaces can be hot to the touch and may cause burns.

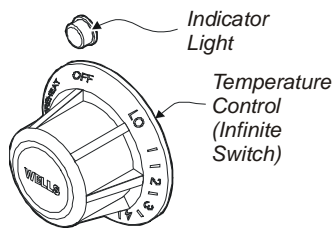

Fig. 9 Roll Warmer  
Temperature Control

### NOTE:

The chart below is intended as a guide ONLY. Your own experience with this appliance, type of foods and method of operation will enable you to determine the temperature control and air vent settings best suited to your operation.

## DRAWER WARMER OPERATION (when provided)

### HEATING OPTIONS

1. Moist heat with Humitrol Rack:
  - a. MOIST operation prevents food from drying out as moisture, as well as heat, is applied to the warming chamber.
  - b. To set for MOIST operation, remove Humitrol Rack from bottom of drawer insert pan and carefully pour approximately 2 quarts of water (½" depth) into the pan. Reinstall rack.
  - c. The Humitrol Rack decreases the sloshing effect of the water in the pan when the drawer is opened. When the drawer is closed, the Humitrol Rack allows steam to rise through the stored product in the drawer.
  - d. Place the food directly on the rack. The rack is designed to support the food off of the steam vents, where water droplets may form.
  - e. Check the water level in the pan periodically, and add water when necessary.
  - f. Set the front air vent between fully closed and half-open. Actual setting will depend upon the type and amount of product stored in the drawer, the temperature setting, and the frequency with which the drawer is opened.
2. Moist heat with pans:
  - a. This Wells warmer is designed to accommodate any combination of standard-size, steam table pans.
  - b. Place a small amount of water in drawer pan. Place pans in drawer pan.
  - c. Check the water level in the pan periodically, and add water when necessary.
3. Dry heat:
  - a. For some applications, you may want to store previously prepared foods in a dry-heat environment. To do so, place the food directly into the empty (i.e. no water) drawer pan.

### OPERATING CHART FOR DRAWER WARMERS

PRODUCT TYPE	RECOMMENDED STORAGE TEMP.	TYPE OF HEAT	CONTROL SETTING	AIR VENT SETTING
Hard Rolls	160-185°F	Dry	7-8	Closed
Soft Rolls	150-175°F	Moist	6-7	Open - ½
Vegetables	175-185°F	Moist	7-8	Open - ½
Meats	165-185°F	Dry	6-8	Closed
Fish	165-185°F	Moist	6-8	Open
Casseroles	150-175°F	Dry	6-7	Closed
Pies, Desserts	160-185°F	Dry	6-7	Closed

## OPERATION (continued)

### DRAWER WARMER OPERATION (when provided)

OPERATING CHART FOR DRAWER WARMERS				
PRODUCT TYPE	RECOMMENDED STORAGE TEMP.	TYPE OF HEAT	CONTROL SETTING	AIR VENT SETTING
Hard Rolls	160-185°F	Dry	7-8	Closed
Soft Rolls	150-175°F	Moist	6-7	Open - ½
Vegetables	175-185°F	Moist	7-8	Open - ½
Meats	165-185°F	Dry	6-8	Closed
Fish	165-185°F	Moist	6-8	Open
Casseroles	150-175°F	Dry	6-7	Closed
Pies, Desserts	160-185°F	Dry	6-7	Closed

## CLEANING INSTRUCTIONS



### **CAUTION:** **Electric Shock Hazard**

Disconnect appliance from electric power before cleaning.



### **CAUTION:** **Hot Surface**

Exposed surfaces can be hot to the touch and may cause burns. Allow appliance to cool before cleaning.

### **IMPORTANT:**

Never allow PRE-FILTER or FILTER PACK to get wet. DO NOT wash either of these two filters. Washing these filters will ruin them and cause the appliance to shut-down.

### **IMPORTANT:**

DO NOT spill or pour water into controls, control panel, wiring or coil-type hotplate elements. Damage to internal components will occur. Damage to internal components from water damage is not covered by warranty.

### **IMPORTANT:**

This appliance is not jet stream approved. Do not direct water jet or steam jet at this appliance, or at any control panel or wiring. Do not splash or pour water on, in or over any controls, control panel or wiring.

### **IMPORTANT:**

DO NOT use steel wool or metal implements to clean drawers or cabinet surfaces.

## VENTILATOR SECTION CLEANING INSTRUCTIONS

### PREPARATION

Disconnect appliance from electric power  
Allow to cool before cleaning

**FREQUENCY** Weekly

### TOOLS

Warm water and a mild detergent  
Soft clean cloth or sponge  
Bristle brush  
Container for disposal of grease

### CLEANING

Disconnect appliance from electric power  
Allow to cool before cleaning

Remove the grease baffle, pre-filter assembly, grease trough and grease cup. Empty the grease trough and grease cup.

Remove the pre-filter from the filter frame. Wash and rinse the filter frame ONLY.

Wash and rinse the grease baffle, grease trough and grease cup in a sink or dishwasher using mild detergent and warm water.  
Allow to air dry.

Reinsert the pre-filter into the filter frame. Reinstall the pre-filter, grease baffle, grease trough and grease cup.

Procedure is complete

## CLEANING INSTRUCTIONS (continued)

### HOTPLATE SECTION

#### PREPARATION

- Disconnect appliance from electric power
- Allow to cool before cleaning

**FREQUENCY** Daily

#### TOOLS

- Warm water and a mild detergent
- Soft clean cloth or sponge
- Plastic scouring pad, plastic scraper

#### CLEANING

- Disconnect appliance from electric power
- Allow to cool before cleaning

#### Spiral Hotplate Elements:

- Raise elements. Remove and empty drip pans.
- Drip pans and element supports may be washed in a sink or dishwasher. Allow to air dry and reinstall.
- Scrape burned-on food debris from element using a plastic scraper or plastic scouring pad. DO NOT use steel wool or metal implements to clean elements.

#### Solid Plate Hotplate Elements:

- Scrape burned-on food debris from element using a plastic scraper or plastic scouring pad. DO NOT use steel wool or metal implements to clean elements.
  - Wipe elements and counter top with a clean cloth or sponge dampened with warm water and a mild detergent. Rinse by wiping with a clean cloth or sponge dampened with warm water.
  - Allow to air dry.
- Procedure is complete.



**CAUTION:**  
**Electric Shock  
Hazard**

Disconnect appliance from electric power before cleaning.



**CAUTION:**  
**Hot Surface**

Exposed surfaces can be hot to the touch and may cause burns. Allow appliance to cool before cleaning.

#### **IMPORTANT:**

DO NOT spill or pour water into controls, control panel, wiring or coil-type hotplate elements. Damage to internal components will occur. Damage to internal components from water damage is not covered by warranty.

#### **IMPORTANT:**

DO NOT use steel wool or metal implements to clean hotplate elements.

## CLEANING INSTRUCTIONS (continued)



### CAUTION: Hot Surface

Exposed surfaces can be hot to the touch and may cause burns.



### CAUTION: Electrical Shock Hazard

DO NOT splash or pour water onto control panel or wiring.



### CAUTION: Heat and Smoke Hazard

Keep the ventilator fan running during any “hot surface” cleaning operation to avoid a build-up of heat and/or smoke.

**IMPORTANT:** Avoid Fire Suppression System discharge!

Keep the ventilator fan running during any “hot surface” cleaning operation to avoid melting a fusible link and causing a discharge of the fire suppression media.

## GRIDDLE CLEANING INSTRUCTIONS

### PRECAUTIONS

Griddle surfaces are HOT. Wear appropriate heat protective gloves, apron and goggles

### FREQUENCY

As Noted

### TOOLS

Scraper, Pumice Stone or Griddle Brick  
Clean Cooking Oil  
Mild Detergent, Soft Cloth or Sponge  
Plastic Scouring Pad

1. To keep the griddle clean and food flavors at their best, scrape the griddle after preparing each order. Scrape excess food into the waste hole in the grease trough (front of the griddle cooking surface). After each 2 - 3 orders, wipe the griddle surface with a light coat of oil.
2. Clean the griddle surface daily, at a minimum:
  - a. Keep the ventilator fan on.
  - b. Set griddle temperature control to 220°F. Allow the griddle temperature to drop to 220°F before proceeding.
  - c. Pour a small amount of water on the griddle surface and let it “sizzle”.
  - d. Use a pumice stone or griddle brick to remove all remaining waste, and to clean the griddle surface down to bright metal. Wipe off any remaining powder residue.
  - e. Use a soft-bristled fiber brush in a circular motion to remove any remaining food particles.
  - f. Turn temperature control to OFF. Allow the griddle surface to cool, then wipe the surface with a clean cloth.
  - g. Dry the griddle surface thoroughly.
  - h. Season the cooking surface after each cleaning using the instructions on page 10.
3. At least once each day, the GREASE TROUGH must be thoroughly cleaned. Using a scraper, remove all grease and food waste from the grease trough and into the grease drawer.
4. After scraping all cooking waste from grease trough into GREASE DRAWER, take the grease drawer to kitchen cleaning area and properly dispose of all waste.
  - a. Clean drawer with hot water and a mild detergent.
  - b. Dry drawer thoroughly and reinstall in griddle.
5. GRIDDLE EXTERIOR:
  - a. Wipe down splash guards, griddle body and the grease trough with a cloth dampened with warm water and a mild detergent.
  - b. A plastic scouring pad and a non-abrasive cleanser may be used for hard-to-remove food particles.
  - c. Rinse thoroughly with clean water. DO NOT splash or pour water onto control panel or wiring.
  - d. Dry griddle with a soft, clean cloth.

## CLEANING INSTRUCTIONS (continued)

### DRAWER WARMER CLEANING INSTRUCTIONS

**PRECAUTIONS:** Turn control knob to OFF.  
Allow drawers to cool before proceeding.  
Remove drawer pans and Humitrol racks.

**FREQUENCY:** Minimum -Daily

**TOOLS:** Warm water and mild detergent  
Clean cloth or sponge

1. Remove drawers from warmer:
  - a. Pull warmer drawer out until fully extended.
  - b. Slide finger along left and right slide rail until you reach the latches (located at the front end of the cabinet-mounted rails)  
Press down on both left and right latch.
  - c. Pull drawer away from warmer.

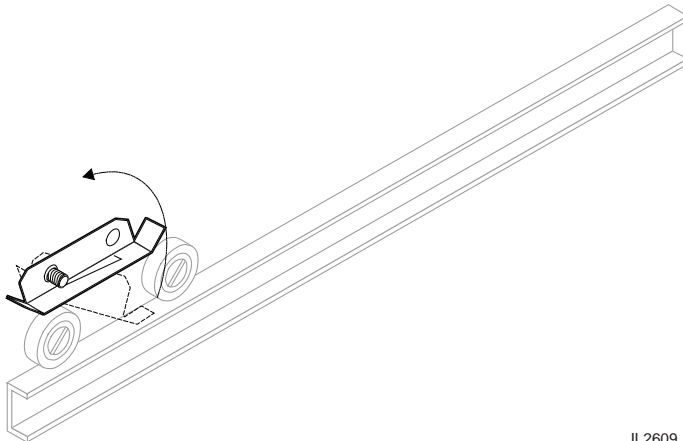

2. Clean drawers, drawer pans, Humitrol Racks and/or insets with warm water and mild detergent.  
Rinse all components thoroughly with clear water.  
Dry all components prior to reinstalling them in warmer.
3. Sweep crumbs and other debris from warmer cavity.
4. Clean the outside of the unit by wiping with a clean cloth or sponge, warm water and mild detergent. Dry with a clean cloth, then wipe with a polish formulated for stainless steel.
5. It is important to keep the slide rails clear and free from debris. Periodic cleaning of the slide rails and other adjoining parts is necessary to assure smooth drawer operation.
6. Check drawer rollers. Be sure they roll freely and that the slide rails are free from debris.
7. Be sure cabinet-mounted drawer catch roller is "up", then re-install drawers.



**CAUTION:**  
**Electric Shock  
Hazard**

Disconnect appliance from electric power before cleaning.



**CAUTION:**  
**Hot Surface**

Exposed surfaces can be hot to the touch and may cause burns. Allow appliance to cool before cleaning.

## MAINTENANCE INSTRUCTIONS



### CAUTION: Shock Hazard

Disconnect appliance from electric power before cleaning.



### CAUTION: Hot Surface

Exposed surfaces can be hot to the touch and may cause burns. Allow appliance to cool before servicing.

## ADJUSTMENTS AND LUBRICATION

### PRECAUTIONS:

Turn control knob to OFF. Unplug warmer. Allow drawers to cool before proceeding. Remove drawer pans and Humitrol racks.

### FREQUENCY:

Minimum - monthly. Every 2 weeks recommended.

### TOOLS:

Screwdrivers, Phillips (+) and flat blade (-). Nut drivers, 3/8" and 7/16". Food-grade lubricant.

1. Check slides on cabinet and drawers for cleanliness.
2. Check all rollers on cabinet and drawers for cleanliness and tightness. Lubricate.
3. Check cabinet drawer stops for operation. Stops must "snap" down positively. Clean and adjust as required.
4. Check cabinet heating element fasteners for tightness.
5. Check all cabinet drawer catches for tightness and operation. Lubricate. Be certain roller is "out" before attempting to install drawer.
6. Check thermostat thermobulb and capillary tube for condition. Thermobulb must be securely mounted in the appropriate holder. Arrange repairs for damaged thermobulb or capillary tube.
7. Check drawer faceplate and handle fasteners for tightness.
8. Check drawer catch clip for tightness.
9. For drawers equipped with gaskets, examine condition of gasket. Arrange repairs for torn or damaged gaskets.
10. Reinstall drawers and check for proper operation. Procedure is complete.

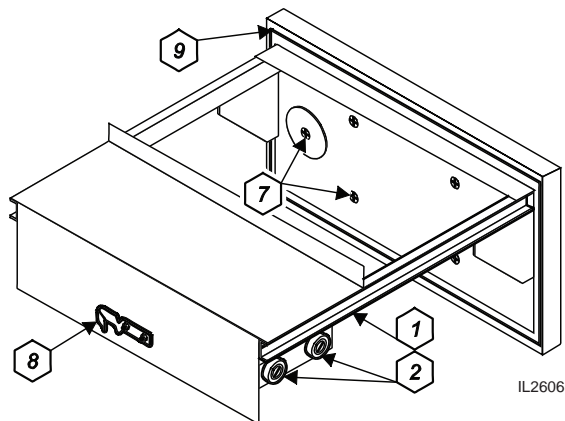
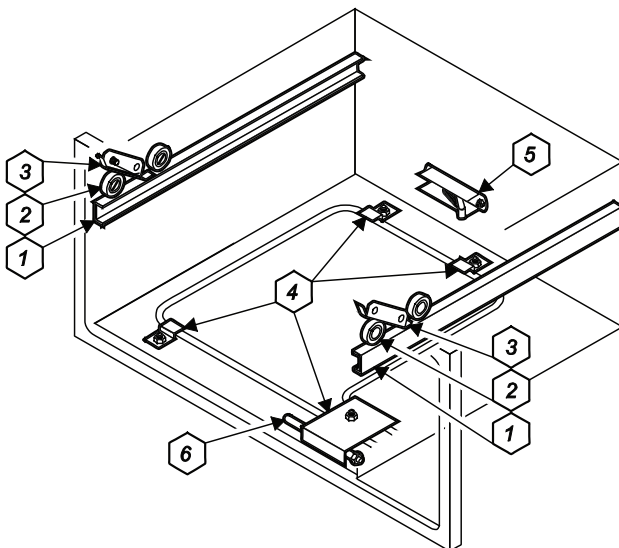

## TROUBLESHOOTING SUGGESTIONS

SYMPTOM	POSSIBLE CAUSE	RECOMMENDED REMEDY
No power to unit	Not plugged in or circuit breaker tripped	Plug unit into power receptacle Reset circuit breaker
Cooking appliances not energized	Filters not properly installed (CHECK FILTERS lit)	Install filters properly
	Filters expended (SERVICE REQUIRED lit)	Replace filters
	Ansul® system discharged or not cocked. (Buzzer sounds)	Contact Ansul® Distributor for service.
	Internal damage	Contact Authorized Wells Service Agent for repairs.
Hotplate (only) will not heat	Hotplate Temperature Control not set	Set Hotplate Temperature Control to desired temperature. Each hotplate is controlled individually.
	Internal damage	Contact Authorized Wells Service Agent for repairs.
Griddle (only) will not heat	Griddle Temperature Control not set	Set Griddle Temperature Control to desired temperature
	Internal damage	Contact Authorized Wells Service Agent for repairs.
Warmer Drawer will not heat	Drawer Temperature Control not set	Set Drawer Temperature Control to desired temperature
	Internal damage	Contact Authorized Wells Service Agent for repairs.

## MAINTENANCE SCHEDULES

USE AND MAINTENANCE SHALL BE IN ACCORDANCE WITH THE STANDARD FOR

VENTILATION CONTROL AND FIRE PROTECTION OF COMMERCIAL COOKING OPERATIONS, N.F.P.A 17A & N.F.P.A. 96 (current editions).



### **DANGER** Fire Hazard

FAILURE TO PROPERLY CLEAN AND MAINTAIN THIS EQUIPMENT CAN

CAUSE A FIRE. AN UNCONTROLLED FIRE CAN CAUSE SERIOUS INJURY,

DEATH AND/OR PROPERTY LOSS.

NOTE: A signed and dated VENTILATOR HOOD MAINTENANCE LOG must be maintained on the premises, and shall be available for inspection by the authority having jurisdiction. See pages 25 & 26.

IMPORTANT: Parts used for the Ansul® fire suppression system are not serviceable by the owner / operator. Procedures for servicing fire suppression equipment are described in:

ANSUL® R-102 SYSTEM DESIGN, INSTALLATION, RECHARGE AND MAINTENANCE MANUAL (Ansul® #418087-05).

1. 6-MONTH MAINTENANCE (MUST BE PERFORMED BY AN AUTHORIZED ANSUL® DISTRIBUTOR ONLY):
  - a. Inspect and test total operation including FIRE DAMPER and all SAFETY INTERLOCKS.
  - b. All FIRE SUPPRESSION SYSTEM actuation components including MANUAL PULL STATION and any REMOTE MANUAL PULL STATION must be inspected for proper operation in accordance with the maintenance schedule published in ANSUL® R-102 SYSTEM DESIGN, INSTALLATION, RECHARGE AND MAINTENANCE MANUAL (Ansul® #418087-05).
  - c. The FIRE SUPPRESSION SYSTEM FUSIBLE LINKS must be inspected. NOZZLES and MANUAL PULL STATION must be cleaned in accordance with ANSUL® R-102 SYSTEM DESIGN, INSTALLATION, RECHARGE AND MAINTENANCE MANUAL (Ansul® #418087-05).
  - d. The FIRE SUPPRESSION AGENT TANK, PIPING and FLEXIBLE TUBING must be Inspected.
2. 12-YEAR MAINTENANCE: (MUST BE PERFORMED BY AN AUTHORIZED ANSUL® DISTRIBUTOR ONLY):
  - a. The FIRE SUPPRESSION AGENT TANK and ¼" FLEX HOSE must be hydrostatically tested, and the FIRE EXTINGUISHING AGENT must be replaced in accordance with the maintenance schedule published in ANSUL® R-102 SYSTEM (STANDARD UL 300 LISTED).
  - b. The FUSIBLE LINKS in plenum and damper must be REPLACED. This maintenance to be performed by qualified Ansul® service personnel only.

Inspection shall be conducted on a monthly basis in accordance with the manufacturer's Operation Manual. At a minimum, this inspection shall include verification of the following:

**WELLS MANUFACTURING**  
VENTILATOR HOOD OWNERS MONTHLY INSPECTION LOG

<b>OPERATION</b>	<b>AGENT / DATE</b>												
Extinguishing system components: In proper place and (visually) in good order													
Manual pull station actuators for fire suppression system are unobstructed													
The maintenance log is in place and up to date													
No obvious physical damage or condition exists that might prevent operation of the fire suppression system													
The nozzle blow-off caps are in place and in good condition													
The hood, duct and protected cooking appliance have not been replaced, modified or relocated													
Clean plenum GREASE BAFFLE and BLOWER (max. interval: 3 months)													
Change PRE-FILTER and FILTER PACK (as required)													

This MAINTENANCE LOG is to be performed and completed by a trained technician who has completed the instruction necessary to perform the maintenance and recharge service.

**WELLS MANUFACTURING  
VENTILATOR HOOD MAINTENANCE LOG**

<b>OPERATION</b>		<b>AGENT / DATE</b>																				
Clean and inspect discharge nozzle in plenum BEFORE filters Max. interval: 6 months																						
Clean and inspect discharge nozzle in plenum AFTER filters Max. interval: 6 months																						
Inspect fire suppression detectors, all releasing devices for actuation, fire suppressant tank liquid level Max interval: 6 months (discharge of fire suppressant not a part of this test)																						
Inspect fire suppression hoses, plumbing and tank for obstructions and any conditions such as, but not limited to, corrosion and pitting. Max. interval: 6 months																						
Inspect and test all filter interlocks Max. interval: 6 months																						
Replace fire suppression links in hood plenum: each link is rated @ 212°F Replace two (2) fire suppression links at cooking appliance: each link is rated @ 212°F Max interval: 12 months	Log TEMP																					
	Log Mfg DATE Stamp																					
Replace fire damper fusible link: rated @ 280°F Max interval: 12 months	Log TEMP																					
	Log Mfg DATE Stamp																					

THIS MAINTENANCE LOG MUST BE KEPT IN A PROTECTIVE COVER PERMANENTLY ATTACHED TO THE APPLIANCE  
Log all repairs and recommendations on reverse side. Any repairs, other than replacement of factory authorized parts, to the fire suppression plumbing system must be subject to hydrostatic pressure testing.

ANSULEX Low pH  
QUICK IDENTIFIER (In Plant Common Name)

Manufacturer's Name: <b>ANSUL INCORPORATED</b>	Emergency Telephone No.: <b>CHEMTREC (800) 424-9300 or (703) 527-3887</b>
Address: One Stanton Street, Marinette, WI 54143-2542	Other Information Calls: (715) 735-7411
Prepared By: Safety and Health Department	Date Prepared: February 1, 1999

**SECTION 1 - IDENTITY**

Common Name (Used on Label): (Trade Name and Synonyms) <b>ANSULEX Low pH Liquid Fire Suppressant</b>	CAS No.: <b>N/A</b>
Chemical Name: <b>N/A This is a Mixture</b>	Chemical Family: <b>Mixture</b>
Formula: <b>N/A</b>	

**SECTION 2 - INGREDIENTS**

<b>PART A - HAZARDOUS INGREDIENTS</b>				
Principal Hazardous Component(s) (chemical and common name(s)):	Wt. %	CAS No.	ACGIH TLV	Acute Toxicity Data
None	N/A	N/A	N/A	N/A
<b>PART B - OTHER INGREDIENTS</b>				
Other Component(s) (chemical and common name(s)):	Wt. %	CAS No.	ACGIH TLV	Acute Toxicity Data
Proprietary Mixture of Organic and Inorganic Salts	48.0 - 50.0	N/A	N/E	NDA
Phosphoric Acid	0.2	7664-38-2	N/E	NDA
EDTA	0.65	64-02-8	N/E	NDA
Yellow-Green Fluorescent Dye	0.011	518-47-8	N/E	Oral LD <sub>50</sub> (rat) 6800 mg/kg
Water	Approx. 50.0	7732-18-5	N/E	NDA

**SECTION 3 - PHYSICAL AND CHEMICAL CHARACTERISTICS (Fire and Explosion Data)**

Boiling Point: 113°C	Specific Gravity (H <sub>2</sub> O=1): 1.33	Vapor Pressure (mm Hg): Not Determined
Percent Volatile by Volume (%): Approx. 50.0	Vapor Density: (Air = 1): 1.03	Evaporation Rate: (Butyl Acetate=1): Approx. 0.005
Solubility in Water: 100%	Reactivity in Water: Mild exothermic reaction	
Appearance and Odor: Fluorescent Yellow Colored Liquid, Mild Odor		
Flash Point: None to boiling	Flammable Limits in Air % by Volume: N/A	Extinguisher Media: N/A
Auto-Ignition Temperature: N/A		
Special Fire Fighting Procedures: NONE - THIS IS AN EXTINGUISHING AGENT		
Unusual Fire and Explosion Hazards: None		

**SECTION 4 - PHYSICAL HAZARDS**

Stability: Unstable <input type="checkbox"/> Stable <input checked="" type="checkbox"/>	Conditions to Avoid: N/A
Incompatibility (Materials to Avoid):	Reactive Metals, ClF <sub>3</sub> , electrically energized equipment, any material reactive with water.
Hazardous Decomposition Products:	Not established, acrid fumes.
Hazardous Polymerization: May Occur <input type="checkbox"/> Will Not Occur <input checked="" type="checkbox"/>	Conditions to Avoid: N/A

M508 p/n 2M-304456 Owners Manual WV-2HG

**SECTION 5 - HEALTH HAZARDS**

ANSULEX Low pH (continued)

Threshold Limit Value:	None Established		
Routes of Entry: Eye Contact:	Irritant		
Skin Contact:	Irritant		
Inhalation:	Not an expected route of entry. Can be irritating to mucous membranes.		
Ingestion:	Irritating to mucous membranes. Acute Oral LD <sub>50</sub> (Sprague-Dawley rats) 825.5mg/kg.		
Signs and Symptoms:	Acute Exposure: Material irritates skin, eyes, and mucous membranes. Chronic Exposure: None known.		
Medical Conditions Generally Aggravated by Exposure:	None known.		
Chemical Listed as Carcinogen or Potential:	National Toxicology Program: Yes <input type="checkbox"/> No <input checked="" type="checkbox"/>	I.A.R.C. Monographs: Yes <input type="checkbox"/> No <input checked="" type="checkbox"/>	OSHA: Yes <input type="checkbox"/> No <input checked="" type="checkbox"/>

**SECTION 6 - EMERGENCY AND FIRST AID PROCEDURES**

Eye Contact:	Flush and irrigate with water for 15 minutes while holding eyelids open. If irritation persists, seek medical attention.
Skin Contact:	Wash thoroughly with soap and water. If irritation persists, seek medical attention.
Inhalation:	Fresh air if symptoms occur. If irritation persists, seek medical attention.
Ingestion:	Dilute by drinking large quantities of water.

**SECTION 7 - SPECIAL PROTECTION INFORMATION**

Respiratory Protection (Specify Type):	N/A		
Ventilation:	Local Exhaust: N/A	Mechanical (General):	N/A
Protective Gloves:	Rubber gloves for spill/leak	Eye Protection:	Chemical goggles recommended during spill/leak procedures.
Other Protective Clothing or Equipment:	Eye wash and safety showers are good safety practice.		

**SECTION 8 - SPECIAL PRECAUTIONS AND SPILL/LEAK PROCEDURES**

Precautions to be taken in Handling and Storage:	Store in original container. Keep tightly closed. Keep separate from acid.
Other Precautions:	See incompatibility information in Section 4.
Steps to be taken in Case Material is Released or Spilled:	Stop leaks. Contain spills. Remove as much as possible. Place in closed container for proper disposal. Wash spill area with large amounts of water to remove traces and neutralize.
Waste Disposal Methods:	Dispose of in compliance with local, state and federal regulations.

**HAZARDOUS MATERIAL IDENTIFICATION SYSTEM**

HAZARD INDEX	
4 SEVERE HAZARD	0 HEALTH
3 SERIOUS HAZARD	
2 MODERATE HAZARD	0 FLAMMABILITY
1 SLIGHT HAZARD	
0 MINIMAL HAZARD	0 REACTIVITY

N/A = Not Applicable      NDA = No Data Available      N/E = Not Established  
ANSUL and ANSULEX are registered trademarks.

Internet Address: <http://www.ansul.com>

# ANSUL® FIRE SUPPRESSION SYSTEM COMPONENTS

**FOR USE ONLY BY AUTHORIZED  
ANSUL® SERVICE PERSONNEL**

Refer to Ansul® part no. 418078-05  
R-102 Restaurant Fire Suppression  
System Design, Installation,  
Recharge and Maintenance

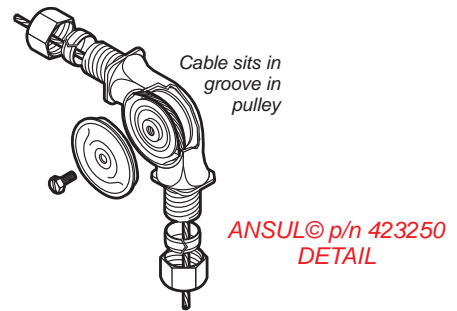
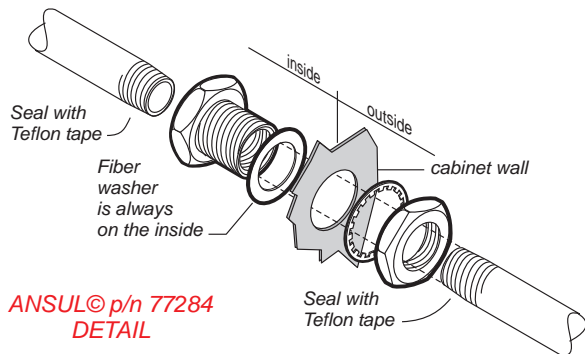
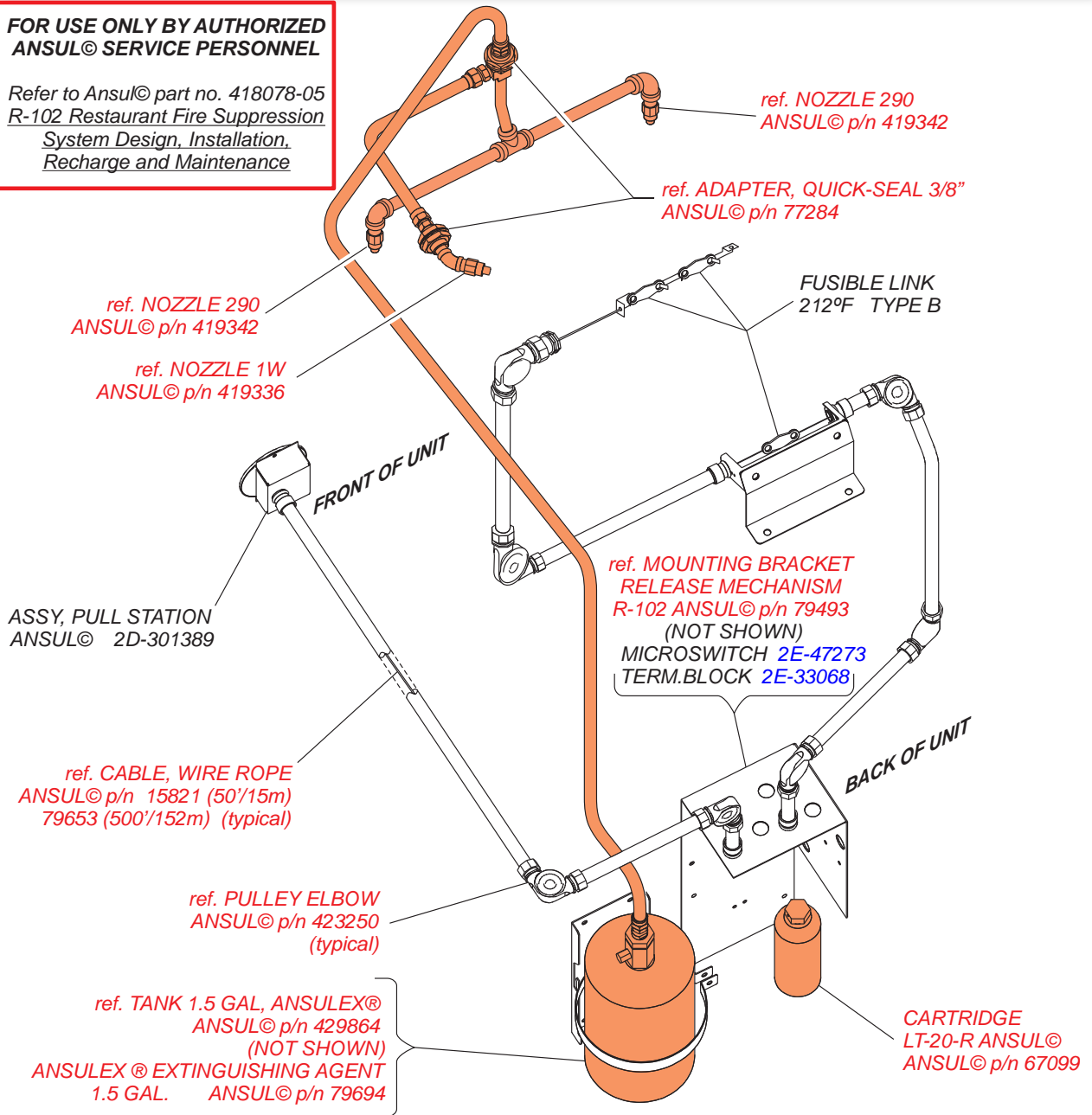

M508 p/n 2M-304456 Owners Manual WV-2HG

IL2277, PL508

# EXPLODED VIEW & PARTS LIST

## HOOD SECTION - CABINET COMPONENTS

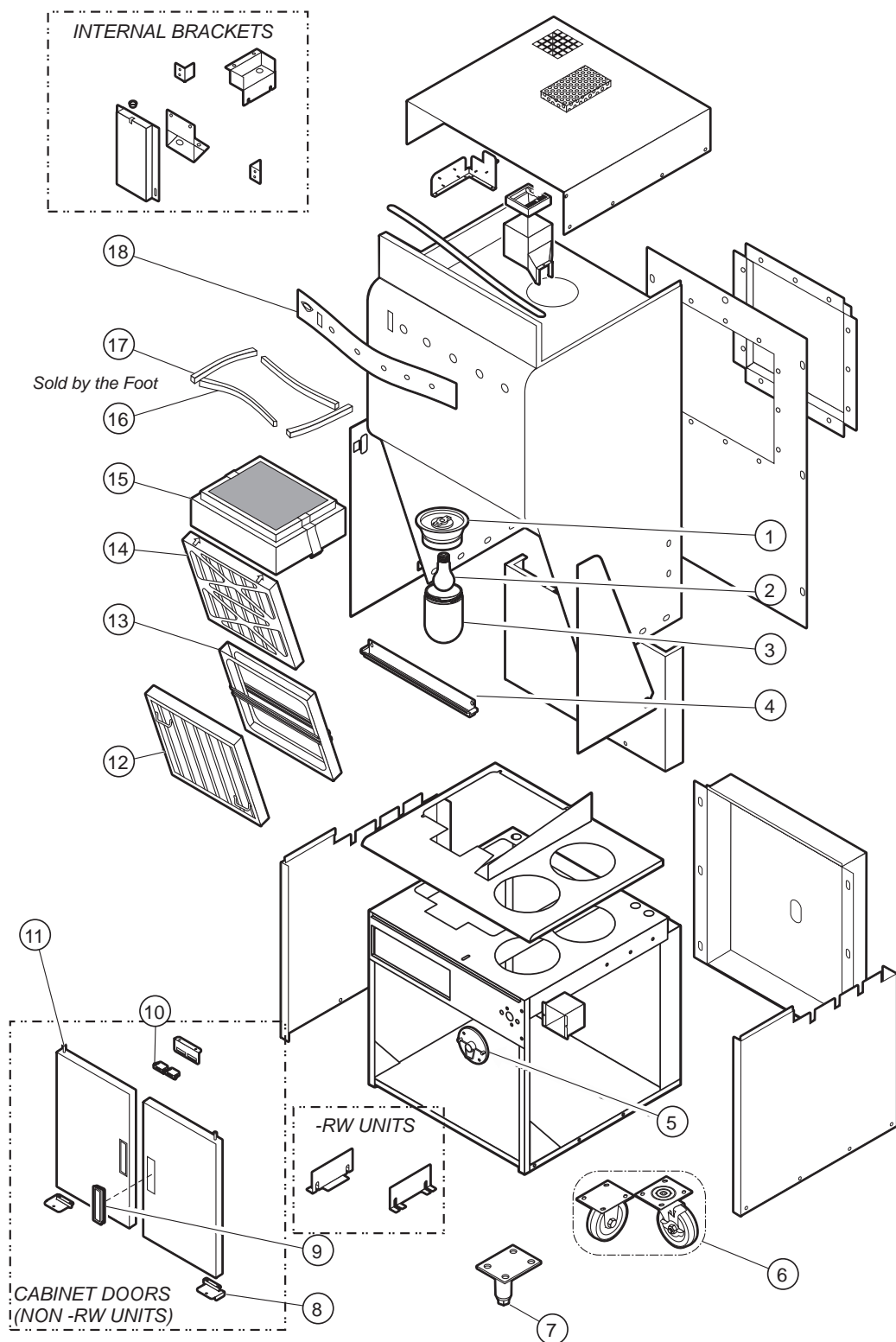

WV2HG; Hood Section - Cabinet Components

M508 p/n 2M-304456 Owners Manual WV-2HG

## EXPLODED VIEW & PARTS LIST

### HOOD SECTION - CABINET COMPONENTS

Model: WV2HG Hood Section - Cabinet Components			
Fig No	Part No	Description	Application
1	2E-305098	LIGHT HOUSING, VCS HOOD	
2	2S-305100	LIGHT BULB/100W-230V, FROSTED	
3	2Q-305099	GLASS GLOBE VCS HOOD	
4	M3-304405	TRAY GREASE DRIP HOOD	
5	2O-308131	REMOTE PULL STATION, RED	
6	5E-20804	CASTER ASSY, 2FIX, 2SWVL	
7	WS-22649	KIT LEG REAR OPT WVF/WVG	
8	M3-304430	DOOR HINGE RIGHT AND LEFT	
9	2R-302166	HANDLE DOOR SNAP IN	
10	2R-46502	MAGNET DOOR	
11	DD-504427	DOOR ASSY LF AND RT WV-FG	
12	2I-302580	FILTER BAFFLE	
13	M3-302688	PREFILTER CAGE	
14	2I-302579	FILTER PRE-HOOD UNIVERSAL	
15	M3-302775	FILTERPACK ASSY UNIV HOOD	
16	1P-302749	TAPE SILICONE GRAY VCS	SOLD BY THE FOOT
17	1P-302749	TAPE SILICONE GRAY VCS	SOLD BY THE FOOT
18	2M-302782	FACEPLATE FRONT	



## EXPLODED VIEW & PARTS LIST

### HOOD SECTION - ELECTRICAL & VACUUM COMPONENTS

Model: WV2HG Hood Section - Electrical Components			
Fig No	Part No	Description	Application
1	<a href="#">2U-302584</a>	BLOWER ASSY UNIVERSAL	
2	<a href="#">2E-Z24058</a>	SWITCH VACCUM #4	
3	<a href="#">2E-Z24056</a>	SWITCH VACCUM #2	
4	<a href="#">2E-Z24055</a>	SWITCH VACCUM #1	
5	<a href="#">2E-Z24057</a>	SWITCH VACCUM #3	
6	2K-37748	FTG CONDUIT STRAIGHT 3/8	
7	<a href="#">2E-300407</a>	SWITCH MANUAL ADVANCE ROT	
8	<a href="#">2J-44834</a>	BUZZER 220V ROHS	
9	<a href="#">2J-31157</a>	LIGHT SIGNAL RED	
10	<a href="#">2J-30516</a>	LIGHT SIGNAL AMBER	
11	<a href="#">2J-35697</a>	PILOT LT GREEN 2502V 1/3W	
12	2E-70395	SWITCH ROCKER 240V 20A	
13	<a href="#">2E-33068</a>	TERM BLOCK FLAME SENSOR	
14	<a href="#">2E-34005</a>	JUMPER FLAME SENSOR TERM	
15	<a href="#">2E-43880</a>	RLY 208/240 DPDT	-RW UNITS ONLY
16	<a href="#">2E-302789</a>	CONTACTOR 50A 3PH 208	50A 3-PH
	<a href="#">2E-306040</a>	CONTACTOR 75A 3-POLE	75A 1-PH
17	<a href="#">2K-304420</a>	STRAIN RELIEF 1 1/4NPT	
18	<a href="#">M3-304438</a>	CORD SET ASSY 6/4 NEMA	6/4 NEMA 15-60P
19	<a href="#">2E-44514</a>	RELAY 208-240V COIL	
20	<a href="#">2Q-305099</a>	GLASS GLOBE VCS HOOD	
21	<a href="#">2S-305100</a>	LIGHT BULB /100W-230V, FROSTED	
22	<a href="#">2E-305098</a>	LIGHT HOUSING VCS HOOD NEW	

# EXPLODED VIEW & PARTS LIST

## COOKTOP SECTION - CABINET & ELECTRICAL COMPONENTS

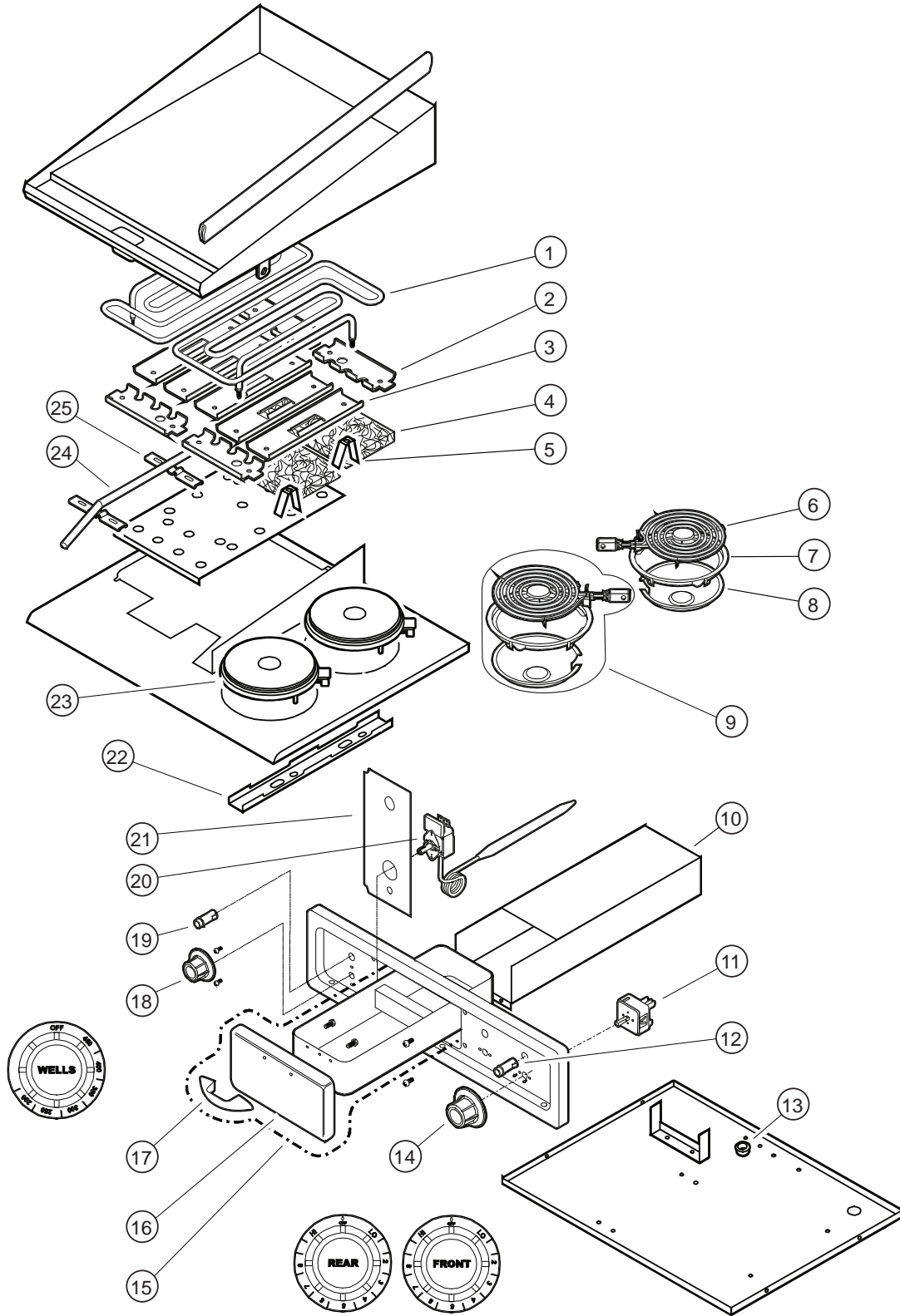

IL2280, PL508

WV2HG; Cooktop Section - Cabinet & Electrical Components

## EXPLODED VIEW & PARTS LIST

### COOKTOP SECTION - CABINET & ELECTRICAL COMPONENTS

Model: WV2HG Cooktop Section - Cabinet & Electrical Components			
Fig No	Part No	Description	Application
1	<a href="#">2N-30512UL</a>	ELEMENT 240V 3000W	
2	<a href="#">G7-32038</a>	CLAMP ELEMENT END LRG GRIDDLE	
3	<a href="#">G7-31968</a>	CLAMP ELEMENT CTR SMALL GRIDDLE	
4	<a href="#">WS-57407</a>	8SF INSULATION OVERSIZED	
5	<a href="#">G7-33474</a>	CLIP TIE DOWN INSUL GRID	
6	<a href="#">2N-30293ELUL</a>	ELEMENT 240V 2600W	
7	<a href="#">2P-6468</a>	RING ELEMENT ADAPTER	
8	<a href="#">2D-30293DT</a>	DRIP TRAY	
9	<a href="#">WS-50293</a>	ELEMENT ASSY KIT, 240V@2600W	
10	<a href="#">WS-51989</a>	SHROUD GREASE DRAWER	
11	<a href="#">2E-30562</a>	SWITCH INFINTE 240V	
12	<a href="#">2J-30516</a>	LIGHT SIGNAL AMBER	
13	<a href="#">2K-31040</a>	BUSHING 7/8" OD	
14	<a href="#">2R-30583</a>	KNOB ASSY FRONT HOTPLATE	FRONT
	<a href="#">2R-30584</a>	KNOB ASSY REAR HOTPLATE	REAR
15	<a href="#">WS-501774</a>	GREASE CAN ASSY	
16	<a href="#">G7-Z12047</a>	PANEL FRONT - GREASE DR	
17	<a href="#">2R-38668</a>	HANDLE GREASE DRAWER GRIDDLE	
18	<a href="#">2R-30259</a>	KNOB CONTROL ASSY	
19	<a href="#">2J-30516</a>	LIGHT SIGNAL AMBER	
20	<a href="#">2T-302825</a>	THERMO 400°F	
21	<a href="#">2A-31974</a>	SHIELD THERMO GRIDD LS	
22	<a href="#">DD-501451</a>	BRKT SOLID ELEM HOLD DOWN	
23	<a href="#">WS-503973</a>	ELM HPLT, UPGRADE FUSED WIRE	
24	<a href="#">2A-31972</a>	TUBE THERMO 18 LINE GRID	
25	<a href="#">G7-32028</a>	CLAMP THERMO BULB GRIDDLE	

# EXPLODED VIEW & PARTS LIST

## DRAWER WARMER SECTION - CABINET & ELECTRICAL COMPONENTS

WS-67096  
heavy duty  
drawer assy  
complete

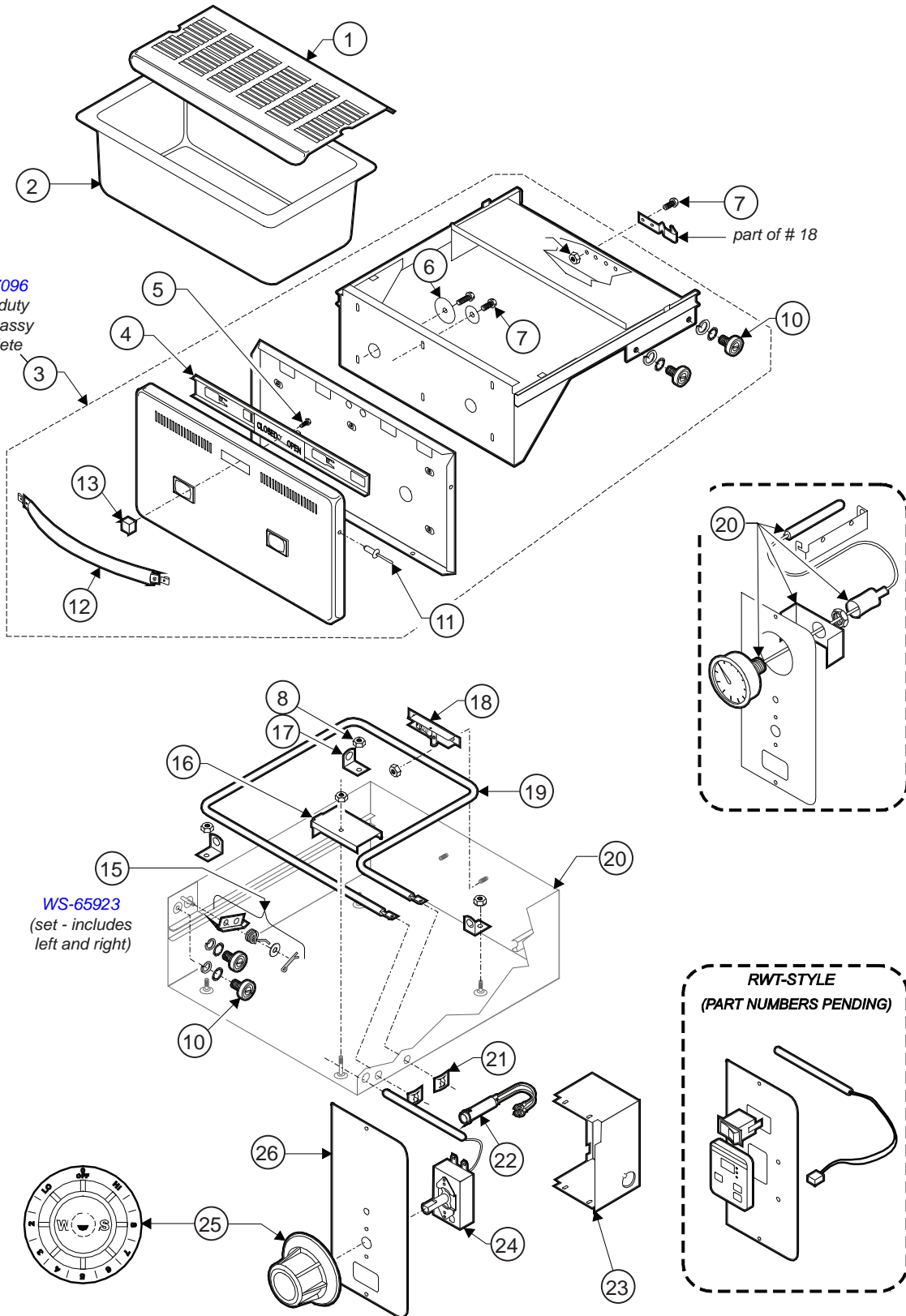

## EXPLODED VIEW & PARTS LIST

### DRAWER WARMER SECTION - CABINET & ELECTRICAL COMPONENTS

Model: WV2HG Drawer Warmer Section - Cabinet & Electrical Components			
Fig No	Part No	Description	Application
1	<a href="#">WS-20624</a>	RACK HUMITROL RWS	OPTIONAL
2	<a href="#">C8-46840</a>	PAN DRAWER RW/RWHD	
3	<a href="#">WS-67096</a>	DRAWER ASY KIT RWHD	
4	<a href="#">C8-49251</a>	SLIDE VENT ASSY RWN	
5	<a href="#">2C-35530</a>	SCREW, 8-32X3/8PH, RD-EACH	
6	<a href="#">2C-35565</a>	WASHER 2 1/16 DRWR BACK	
7	<a href="#">2C-35487</a>	SCREW 8-32X5/16 PH TR HD	
8	<a href="#">2C-35455</a>	NUT 8-32 HEX MS SS	
9			
10	<a href="#">2P-30483</a>	BRNG RLLR TRK-R116	
11	<a href="#">2C-49395</a>	RIVET POP 1/8X .265 SS	
12	<a href="#">C8-32112</a>	HANDLE RW DRAWER SRW320	
13	<a href="#">WS-51796</a>	KNOB SQUARE ROLL WARMER	
14	2T-44475	THERMOMETER RW 2IN DIAL	OPTIONAL TERMOMETER
15	<a href="#">WS-65923</a>	REPR KIT-DRW STOP W/SPRING	
16	<a href="#">C8-35683</a>	SHEILD BULB RWS	
17	<a href="#">C8-35677</a>	ANGLE SUPPORT ELEM RWS	
18	<a href="#">2C-30471</a>	DRAWER STRIKE AND CATCH	
19	<a href="#">2N-30482UL</a>	ELEM 240V 450W	240V
	<a href="#">2N-30519UL</a>	ELEM 120V 450W	120V
20	<a href="#">C8-307637</a>	CAVITY ASSY RW-HD	
21	2C-43271	CLIP RETAINER PILOT LIGHT	
22	<a href="#">2J-35687</a>	LT SIGNAL GLODOT	
23	<a href="#">C8-307569</a>	BOX OUTLET	
24	<a href="#">WS-58936</a>	THERMO CTL KIT RW W/O AUX	
25	<a href="#">2R-30372</a>	KNOB CONTROL ASSY, WARM	
26	<a href="#">C8-Z12392</a>	CONTROL PANEL	UPPER
	<a href="#">C8-33565</a>	PANEL CONTROL LOWER RWS	LOWER

# WIRING DIAGRAM

## HOOD SECTION

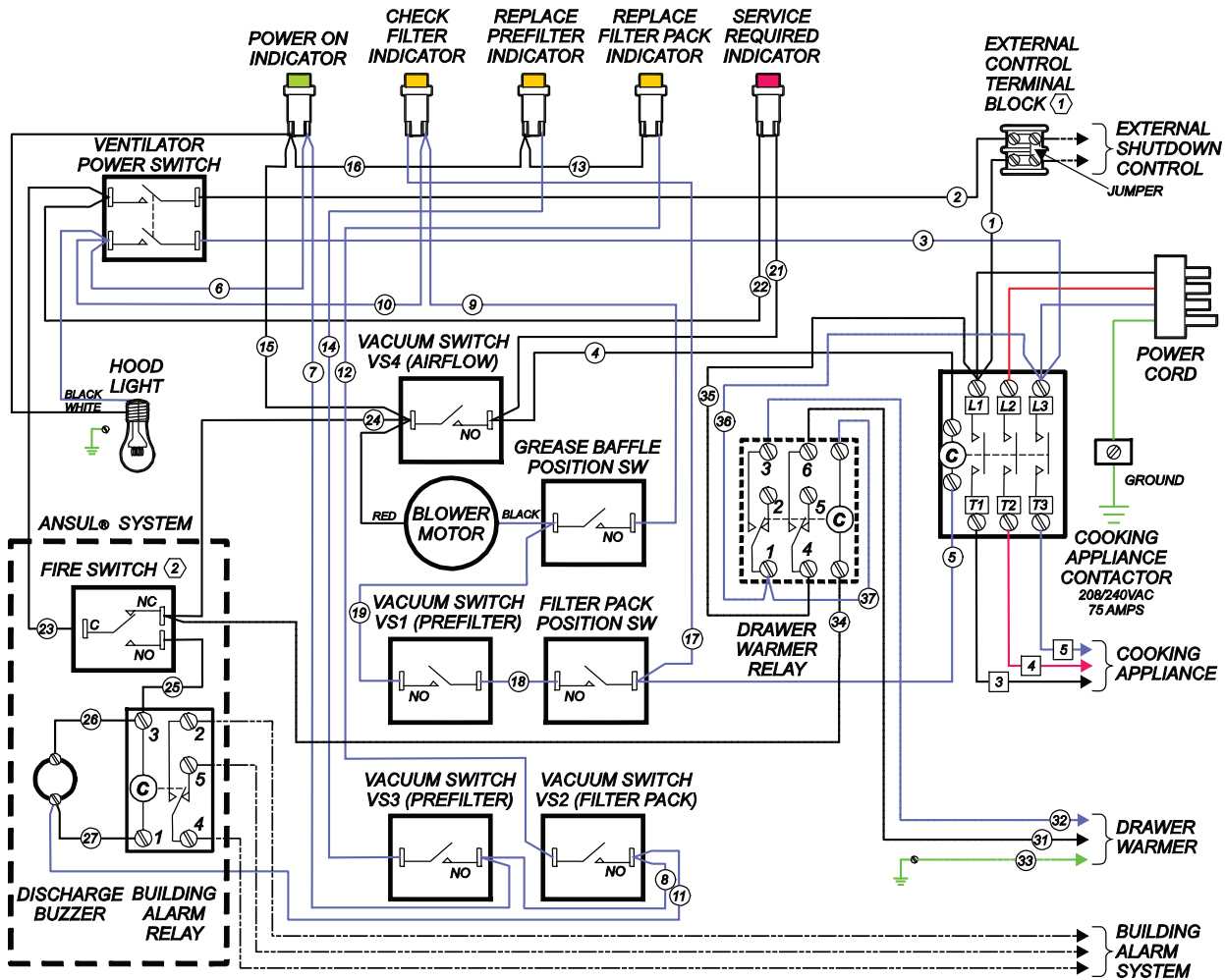

### NOTES

1. REMOVE JUMPER WHEN USING EXTERNAL CONTROL.  
**IMPORTANT:** DO NOT CONNECT ANY POWER TO EXTERNAL CONTROL TERMINAL BLOCK!
2. FIRE SWITCH SHOWN WITH ANSUL® SYSTEM CHARGED AND COCKED

MODEL	VOLTS 60Hz	3ø AMPS			1ø AMPS	WATTS
		L1	L2	L3		
WV-2HG	208V	16	32	23	38	8,000
	240V	18	35	24	41	9,900
WV-2HGRW	208V	19	32	26	43	8,900
	240V	21	35	27	46	11,100
WV-2HSG	208V	21	35	24	42	8,675
	240V	23	38	24	45	10,800
WV-2HSGRW	208V	23	35	26	46	9,575
	240V	26	38	27	50	12,000

from p/n 2M-305991 Rev. A

# WIRING DIAGRAM

## COOKTOP SECTION

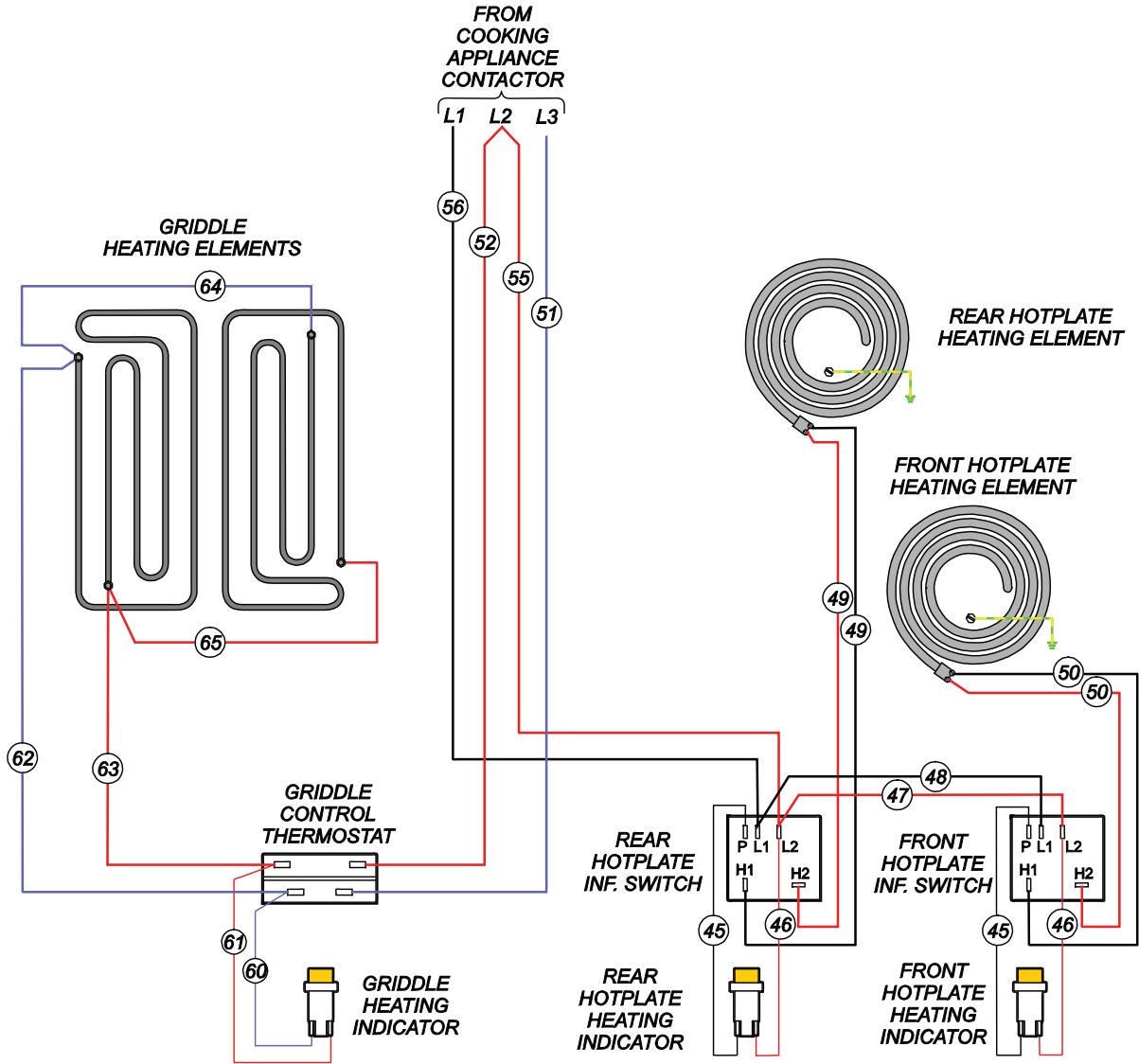

from p/n 2M-305991 Rev. A

# WIRING DIAGRAM

## DRAWER WARMER SECTION RW-STYLE

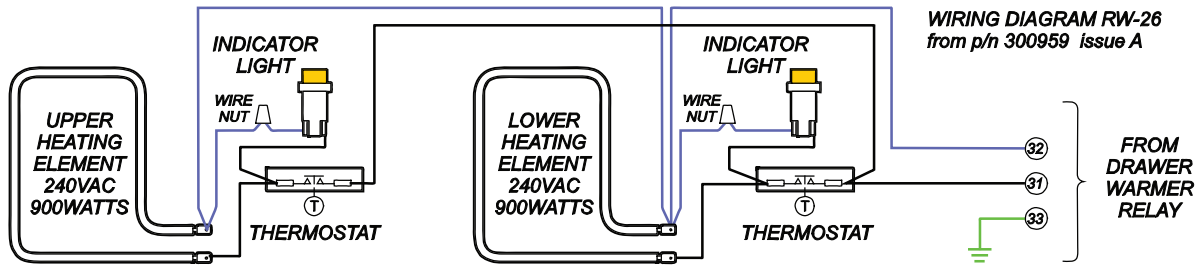

## DRAWER WARMER SECTION - RWT-STYLE

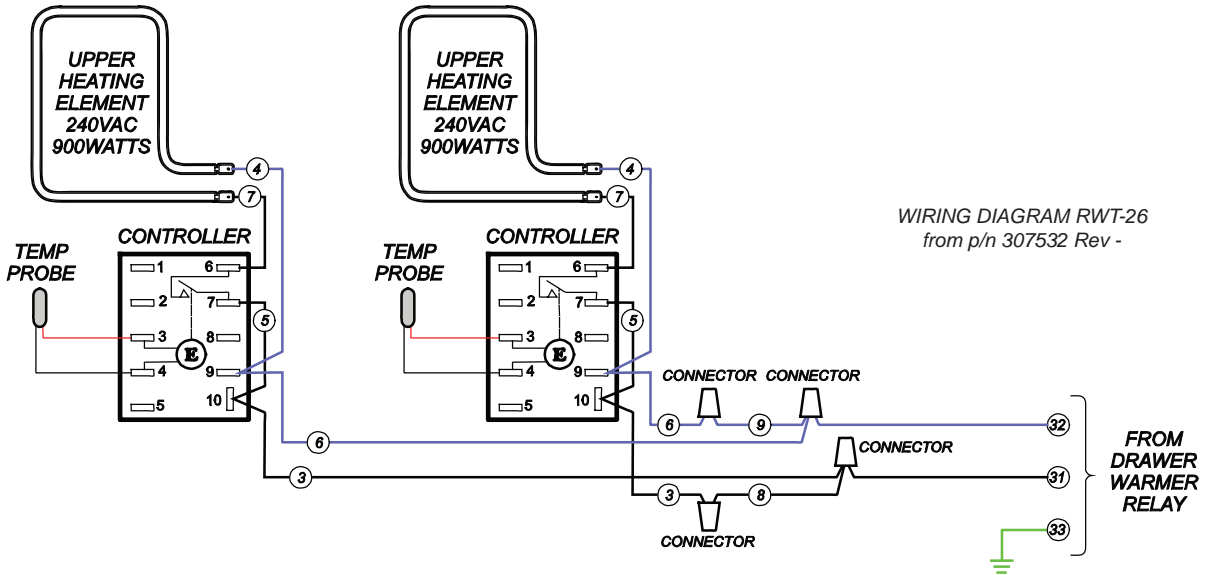

## PARTS & SERVICE

### DESCRIPTION

OVEN RACK Replacement  
 PRE-FILTER  
 PRE-FILTER CAGE  
 FILTER PACK (HI-EFFICENCY + CHARCOAL)  
 GREASE BAFFLE  
 GREASE DRIP TRAY  
 LEG ADJUSTMENT, 6IN  
 CASTER  
 DRIP TRAY FOR SPIRAL ELEMENT HOTPLATE  
 HUMITROL RACK  
 DRAWER WARMER PAN

### SERVICE PART NO.

2B-50200-34  
 2I-302579  
 M3-302688  
 M3-302775  
 2I-302580  
 M3-304405  
 2A-45598  
 2P-43763  
 I7-30292  
 WS-20624  
 DD-22412

**IMPORTANT:** Use only factory authorized service parts and replacement filters.

For factory authorized service, or to order factory authorized replacement parts, contact your Wells authorized service agency, or call:

Wells Manufacturing  
 265 Hobson Street  
 Smithville, Tennessee 37166 U.S.A.

WELLS BULLETIN (ANSUL® PARTS LIST)

DD-303331

Service Dept.  
 phone: (800) 264-7827

NOTE: Ansul® Manual 418087-05 and Wells Bulletin 303331 are intended for use by authorized Ansul® service personnel only. Ansul® Manual 418087-05 must be obtained through your authorized Ansul® distributor.

Service Parts Department can supply you with the name and telephone number of the WELLS AUTHORIZED SERVICE AGENCY nearest you.

### CUSTOMER SERVICE DATA

please have this information available if calling for service

RESTAURANT \_\_\_\_\_ LOCATION \_\_\_\_\_  
 INSTALLATION DATE \_\_\_\_\_ TECHNICIAN \_\_\_\_\_  
 SERVICE COMPANY \_\_\_\_\_  
 ADDRESS \_\_\_\_\_ STATE \_\_\_\_\_ ZIP \_\_\_\_\_  
 TELEPHONE NUMBER (\_\_\_\_) \_\_\_\_\_ - \_\_\_\_\_  
 EQUIPMENT MODEL NO. \_\_\_\_\_  
 EQUIPMENT SERIAL NO. \_\_\_\_\_  
 VOLTAGE: (check one)  208  240



**SERVICE TRAINING - QUALITY SERVICE**



**CUSTOMER SATISFACTION**



**WELLS MANUFACTURING**  
265 Hobson Street, Smithville, Tennessee 37166

telephone: (800) 264-7827  
[www.wells-mfg.com](http://www.wells-mfg.com)