



WELLS BLOOMFIELD, LLC
265 Hobson St. • Smithville, TN 37166
telephone: (800) 264-7827
wells-mfg.com



OWNERS MANUAL

WV-4H SERIES

**HOTPLATE
COOKTOP
with
UNIVERSAL
HOOD**

**MODELS:
WV4HF
WV4HFRW
WV4HS
WV4HSRW**

**Includes
INSTALLATION
USE & CARE
EXPLODED VIEW
PARTS LIST
WIRING DIAGRAM**

Model WV-4HSRW

IMPORTANT: DO NOT DISCARD THIS MANUAL

This manual is considered to be part of the appliance and is to be given to the OWNER or MANAGER of the restaurant, or to the person responsible for TRAINING OPERATORS of this appliance. Additional manuals are available from your WELLS DEALER.

THIS MANUAL MUST BE READ AND UNDERSTOOD BY ALL PERSONS USING OR INSTALLING THIS APPLIANCE. Contact your WELLS DEALER if you have any questions concerning installation, operation or maintenance of this equipment.

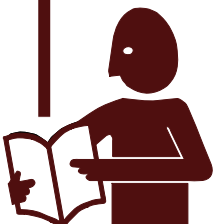

LIMITED EQUIPMENT WARRANTY

Wells Manufacturing warrants to the original purchaser of new Wells products to be free from defects in material or workmanship, under normal and proper use and maintenance service as specified by Wells and upon proper installation and start-up in accordance with the instructions supplied with each Wells unit. Wells' obligation under this warranty is limited to a period of one [1] year from the date of original installation, or eighteen [18] months from original invoice date, whichever occurs first. Defects that occur as a result of normal use, within the time period and limitations defined in this warranty, will at Wells' discretion have the parts replaced or repaired by Wells or a Wells-authorized service agency.

THIS WARRANTY IS SUBJECT TO ALL LISTED CONDITIONS

Repairs performed under this warranty are to be performed by a Wells authorized service agency. Wells will not be responsible for charges incurred or service performed by non-authorized repair agencies. In all cases, the nearest Wells-authorized service agency must be used. Wells will be responsible for normal labor charges incurred in the repair or replacement of a warrantied product within 50 miles (80.5 km) of an authorized service agency. Time and expense charges for anything beyond that distance will be the responsibility of the owner. All labor will need to be performed during regular service hours. Any overtime premium will be charged to the owner. For all shipments outside the U.S.A. and Canada, please see the International Warranty for specific details. It is the responsibility of the owner to inspect and report any shipping damage claims, hidden or otherwise, promptly following delivery. No mileage or travel charges will be honored on any equipment that is deemed portable. In general, equipment with a cord and plug weighing less than 50 lb. (22.7 kg) is considered portable and should be taken or shipped to the closest authorized service agency, transportation prepaid.

CONTACT

Should you require any assistance regarding the operation or maintenance of any Wells Manufacturing; phone or email our service department. In all correspondence provide the model number and serial number of the unit needing service; include the voltage or gas type.

Normal Business Hours: 8:00 a.m. to 4:30 p.m. Central

Telephone: 800-264-7827 Tech Service Option 2

Email: TechService@partstown.com

www.Wells-Mfg.com

PRODUCTS	PARTS	LABOR
Universal Ventless Hoods (WVU)	1 year	1 year
Canopy Ventless Hoods (WVC)	1 year	1 year
"Cook and Hold" equipment (HW10, HWSMP, LLSC7, LLSC7WA, LLSC11, LLSC11WA)	1 years	1 year
Cast iron grates, burners and burner shields	1 year	
Original Wells parts sold to repair Wells Equipment	90 days	

WARRANTY EXCLUSIONS

THE FOLLOWING WILL NOT BE COVERED UNDER WARRANTY.

Wells' sole obligation under this warranty is limited to either repair or replacement parts, subject to the additional limitations detailed below. This warranty neither assumes nor authorizes any person to assume obligations other than those expressly covered by this warranty.

- Any product which has not been used, maintained, or installed in accordance with the directions published in the appropriate installation sheet and/or owner's manual, including incorrect gas or electrical connection. Wells is not liable for any unit which has been mishandled, abused, misapplied, subjected to harsh chemicals, modified by unauthorized personnel, damaged by flood, fire, or other acts of nature [or God], or which have an altered or missing serial number.
- Installation, labor, and job checkouts, calibration of heat controls, air and gas burner/bypass/pilot adjustments, gas or electrical system checks, voltage and phase conversions, cleaning of equipment, or seasoning of griddle surface.
- Replacement of fuses or resetting of circuit breakers, safety controls, or reset buttons.
- Replacement of broken or damaged glass components, quartz heating elements, and light bulbs.
- Labor charges for all removable and consumable parts in gas charbroilers and hotplates, including but not limited to burners, grates, and radiants.
- Any labor charges incurred by delays, waiting time, or operating restrictions that hinder a service technician's ability to perform service.
- Replacement of parts that fail or are damaged due to normal wear or labor for replacement of parts that can be replaced during a daily cleaning routine, such as but not limited to silicone belts, PTFE non-stick sheets, control labels, knobs, bulbs, fuses, quartz heating elements, baskets, racks, and grease drawers.
- Any economic loss of business or profits.
- Non-OEM parts. Use of non-OEM parts without Wells' approval will void the warranty.
- Units exceeding one [1] year from original installation date, or more than eighteen [18] months from original invoice date, whichever comes first.

ADDITIONAL WARRANTIES

- Specific/chain-specific equipment may have additional and/or extended warranties.

The foregoing warranty is in lieu of any and all other warranties expressed or implied and constitutes the entire warranty.

TABLE OF CONTENTS

WARRANTYxi
SPECIFICATIONS	1
FEATURES & OPERATING CONTROLS	2
PRECAUTIONS & GENERAL INFORMATION	6
AGENCY LISTING INFORMATION	7
INSTALLATION	8
OPERATION	12
CLEANING INSTRUCTIONS	17
MAINTENANCE SCHEDULES	21
MSDS (Ansulx Low pH)	24
TROUBLESHOOTING SUGGESTIONS	26
ANSUL® COMPONENTS	27
EXPLODED VIEW & PARTS LIST	28 - 35
WIRING DIAGRAM	36 - 38
PARTS & SERVICE	41
CUSTOMER SERVICE DATA	41

INTRODUCTION

Thank You for purchasing this Wells Manufacturing appliance.

Proper installation, professional operation and consistent maintenance of this appliance will ensure that it gives you the very best performance and a long, economical service life.

This manual contains the information needed to properly install this appliance, and to use and care for the appliance in a manner which will ensure its optimum performance.

SPECIFICATIONS

ELECTRICAL SPECIFICATIONS

MODEL	ROLL WARMER	VOLTS 50/60 Hz	3ø AMPS			1ø AMPS	WATTS	NEMA PLUG	
			L1	L2	L3			1 PHASE	3 PHASE
WV-4HF	NO	208V	16	15	26	30	6,300	6-50P	15-60P
		240V	18	17	30	35	8,300	6-50P	15-60P
WV-4HFRW	YES	208V	19	15	30	34	7,000	6-50P	15-60P
		240V	22	17	34	38	9,100	6-50P	15-60P
WV-4HS	NO	208V	20	19	34	39	8,100	6-50P	15-60P
		240V	23	22	39	45	10,700	NO CORD	15-60P
WV-4HSRW	YES	208V	19	15	30	34	7,000	NO CORD	15-60P
		240V	27	22	43	48	11,500	NO CORD	15-60P

Minimum clearances required from unit to nearest combustible surface or object

	BACK	SIDE	BOTTOM	TOP
inches	n/a	6	6	19
millimeters	n/a	152	152	483

FEATURES & OPERATING CONTROLS

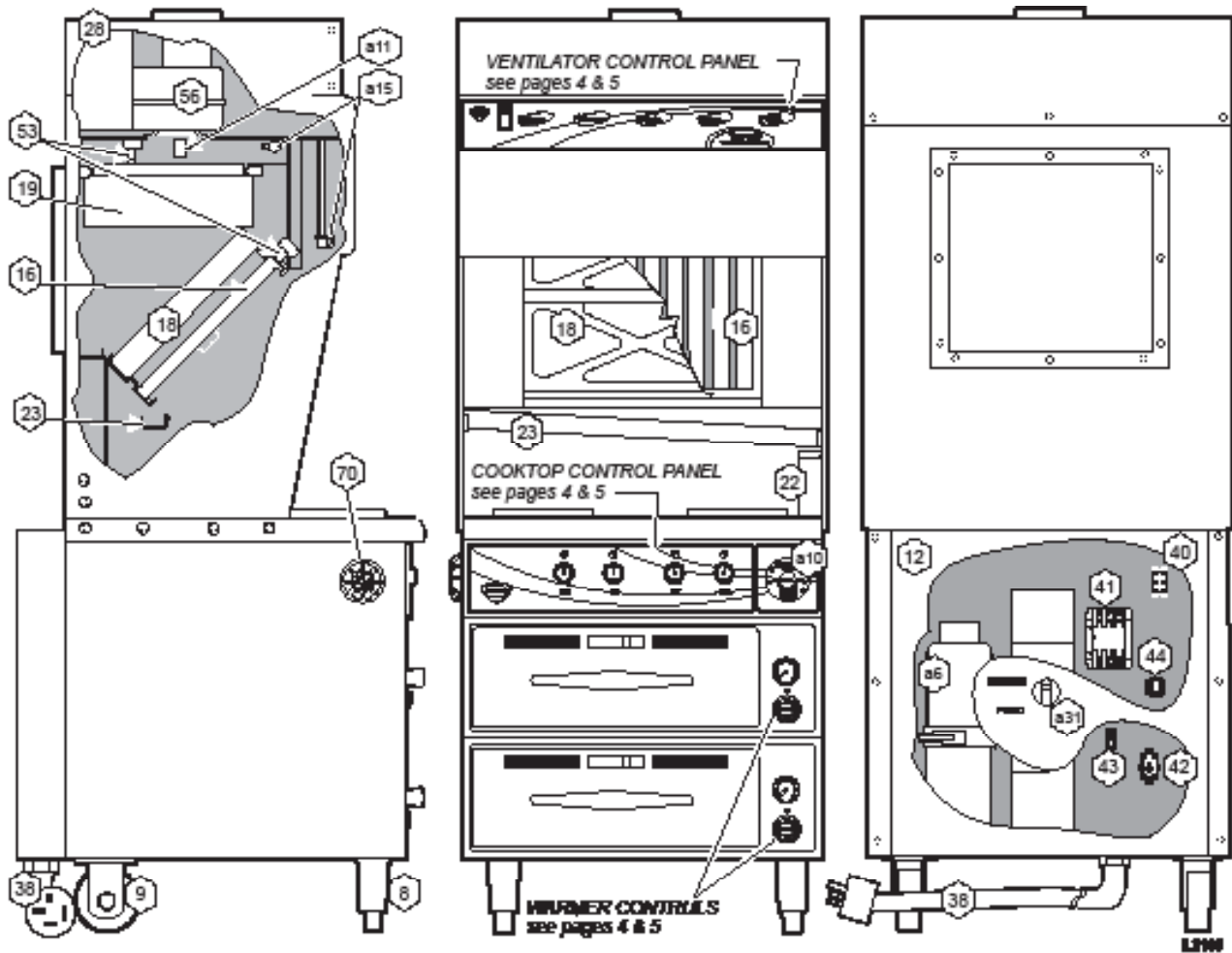

Fig. 1 Ventilator Section Operating Features & Controls

FEATURES & OPERATING CONTROLS (continued)

VENTILATOR SECTION		
ITEM	DESCRIPTION	COMMENT
a6.	FIRE SUPPRESSION AGENT TANK (1.5 gal.)	Container for Ansul TM Low-pH liquid fire suppression liquid.
8	ADJUSTABLE (FRONT) LEG	Allows the unit to be leveled.
9	RIGID (REAR) CASTER	Allows the unit to be easily positioned by lifting the front of the unit slightly.
a10.	MANUAL PULL STATION	Provides a means of manual activation of the fire suppression system. PULL ONLY IN CASE OF FIRE!
a11.	FUSIBLE LINKS	Automatically activates fire suppression system in the event of fire on the cooktop.
12	LOWER REAR ACCESS PANEL	Allows access to Ansul [®] fire suppression agent tank (a6) and controls also access to main power contactor (41).
a15.	DISCHARGE NOZZLE	Fire suppression media discharges here (2 places).
16	GREASE BAFFLE	Extracts and drains most grease and moisture from the air flow.
18	PRE-FILTER ASSEMBLY	Comprises the PRE-FILTER FRAME and a replaceable PRE-FILTER. Stops larger particles of grease from reaching the FILTER PACK for reduced maintenance costs.
19	HEPA/CHARCOAL FILTER PACK	Stops most grease and smoke particles. Also assists in some cooking odor removal.
22	GREASE CUP	Collects grease/moisture drained from grease trough (23).
23	GREASE TROUGH	Directs grease/moisture removed by grease baffle to grease cup.
28	VENTILATOR EXHAUST DUCT	Exit point for ventilator airflow - on top left rear of unit. DO NOT BLOCK
a31.	STATUS INDICATOR	Displays status of fire suppression system (<i>COCKED - FIRED</i>) If <i>FIRED</i> , a buzzer will sound continuously.
38	POWER CORD	6' cord and cap. Plug for NEMA 15-60R (receptacle by user).
40	WARMER RELAY	Provides power to roll warmer section. Energized at all times except during fire safety shut-down.
41	POWER CONTACTOR	Energizes cooktop only while ventilator section is sensed as operational.
42	BUILDING FIRE ALARM RELAY	Reports fire alarm condition to building fire management system.
43	GROUND LUG	Ground wire of power cord connects here.
44	INTERLOCK TERMINAL	Provides connection for shut-down control by building fire management system.
56	VENTILATOR FAN	Provides air movement for ventilation.
70	COOLING FAN	Provides cooling for cooktop controls.

FEATURES & OPERATING CONTROLS (continued)

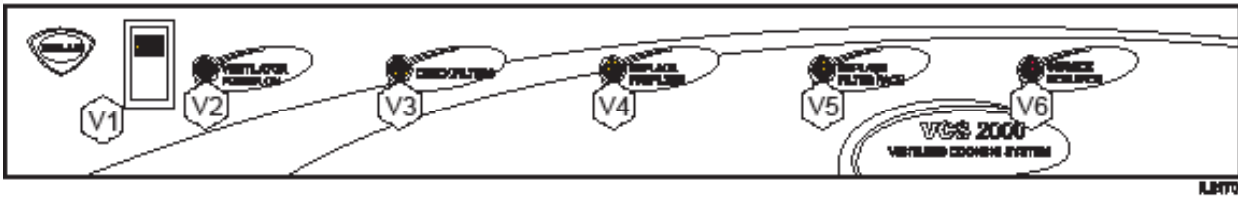

Fig. 2 Ventilator Section Controls & Indicator Lights

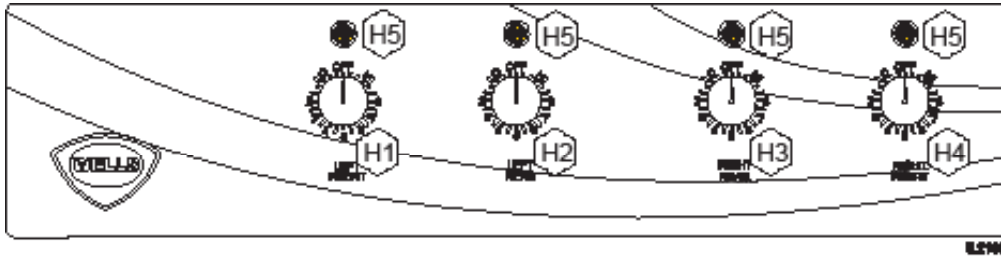

Fig. 3 Cooktop Section Controls & Indicator Lights

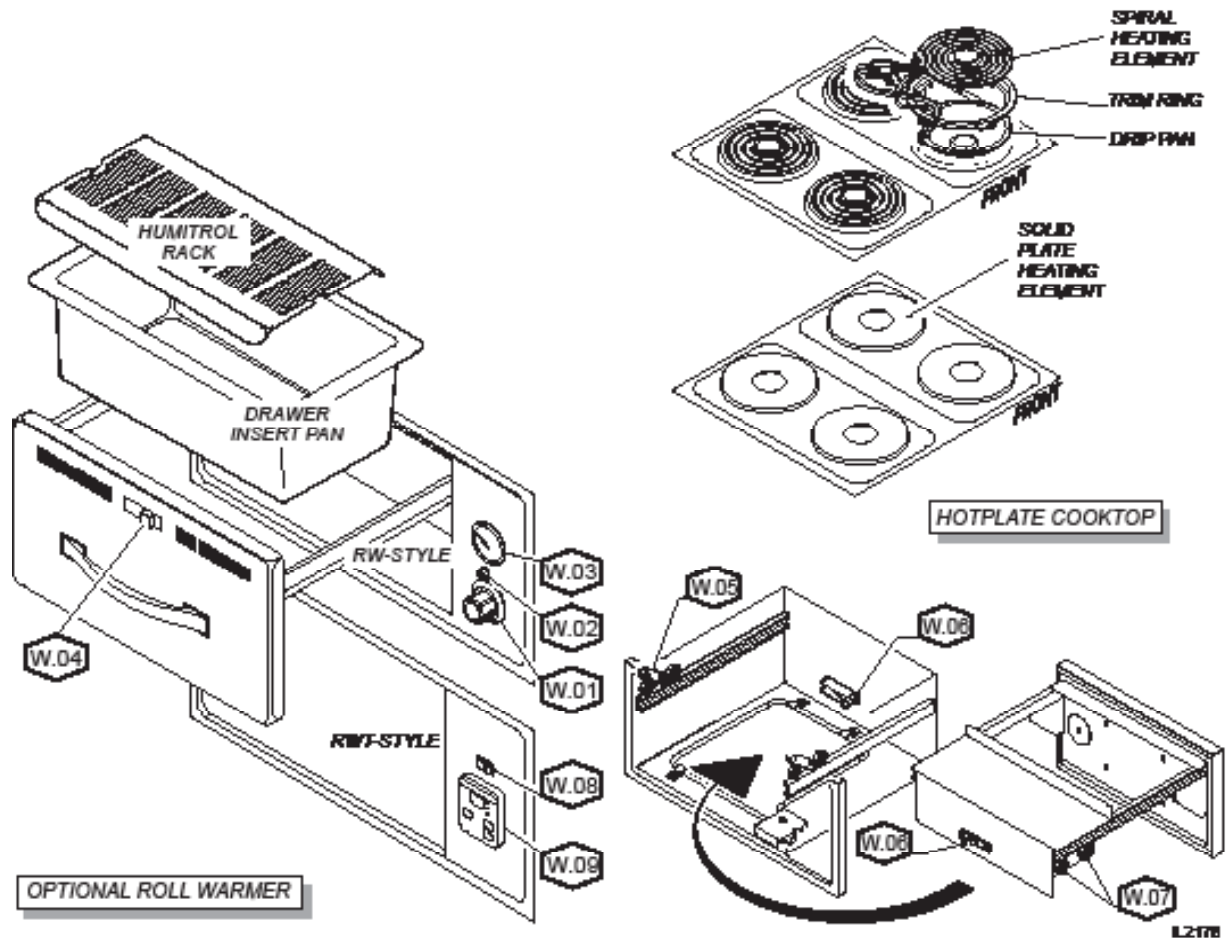

Fig. 4 Cooktop & Warmer Drawer Operating Features & Controls

FEATURES & OPERATING CONTROLS (continued)

ITEM	DESCRIPTION	COMMENT
VENTILATOR SECTION CONTROLS		
V1	POWER SWITCH	Energizes blower motor. If, after 10 seconds, proper conditions are met, cooktop is energized.
V2	POWER <i>ON</i> INDICATOR	GREEN. Glows when POWER switch is <i>ON</i> .
V3	<i>CHECK FILTERS</i> ALARM INDICATOR	AMBER. Glows if one or more filters are out of position. Check all filters and baffles for proper installation.
V4*	<i>REPLACE PREFILTER</i> ALARM INDICATOR	AMBER. Glows when PREFILTER is approaching the end of its service life and must soon be replaced.
V5*	REPLACE FILTER PACK ALARM INDICATOR	AMBER. Glows when FILTER PACK is approaching the end of its service life and must soon be replaced.
V6*	SERVICE REQUIRED ALARM INDICATOR	RED. Glows when PREFILTER and/or FILTER PACK has reached the end of its service life and is too loaded to allow sufficient air flow. Filter MUST be replaced. Appliance is <i>SHUT DOWN</i> until expended filters are replaced.
COOKTOP SECTION CONTROLS		
H1	LEFT FRONT HOTPLATE CONTROL	Infinite switch control of temperature of one hotplate section.
H2	LEFT REAR HOTPLATE CONTROL	Infinite switch control of temperature of one hotplate section.
H3	RIGHT REAR HOTPLATE CONTROL	Infinite switch control of temperature of one hotplate section.
H4	RIGHT FRONT HOTPLATE CONTROL	Infinite switch control of temperature of one hotplate section.
H5	POWER ON INDICATOR	AMBER. Glows when temperature control is turned <i>ON</i> .
OPTIONAL WARMER SECTION CONTROLS		
W.01	TEMPERATURE CONTROL	Infinite switch control of temperature of one warmer drawer.
W.02	POWER ON INDICATOR	AMBER. Glows when associated temperature control is turned <i>ON</i> .
W.03	THERMOMETER (optional)	Reads temperature inside drawer cavity. Must be ordered at time of initial build.
W.04	HUMIDITY CONTROL	Slide control of shutters to control air circulation within the warmer drawer.
W.05	DRAWER CATCH	Holds drawer closed.
W.06	DRAWER STOP	Prevents drawer from opening too far. Spring loaded to permit easy removal of drawer.
W.07	DRAWER ROLLERS	Support drawer and allow it to open and close smoothly.
W.08	POWER SWITCH (RWT)	Energizes unit (RWT-style only)
W.09	CONTROLLER	Controls cavity temperature. Readout displays setpoint and actual temperature information. UP ARROW / DOWN ARROW keys allow modification of setpoint temperature. (RWT-style units only)

PRECAUTIONS AND GENERAL INFORMATION



WARNING: ELECTRIC SHOCK HAZARD

All servicing requiring access to non-insulated electrical components must be performed by a factory authorized technician.

DO NOT open any access panel which requires the use of tools. Failure to follow this warning can result in severe electrical shock.



CAUTION: RISK OF DAMAGE

DO NOT connect or energize this appliance until all installation instructions are read and followed. Damage to the appliance will result if these instructions are not followed.

NOTE: Fire suppression system and all associated components must only be serviced by an authorized Ansul® Distributor. All setup, charging, repair and/or adjustment of the fire suppression system must be performed by an Authorized Ansul® Distributor ONLY.

IMPORTANT: If a remote pull station is installed, both rear casters (9) must be replaced with legs to deter moving the unit. **MOVING AN APPLIANCE WITH A REMOTE PULL STATION WILL DISCHARGE THE FIRE SUPPRESSION SYSTEM.**

This Ventless Cooking System™ is designed to help reduce odor emissions, but will not completely eliminate cooking odors. Air exchange at the installation site must comply with the requirements of the local jurisdictional authority. To ensure that odors do not build-up, recommended minimum air exchange is 300 - 400 cfm of outside air into and out of the area where the unit is used. Recommend use of wall fan (GRAINGER # 4C707) and wall switch (Grainger #4C254), to be supplied by user.

This appliance is intended for use in commercial establishments only.

This appliance is intended to prepare food for human consumption. No other use is recommended or authorized by the manufacturer or its agents.

Operators of this appliance must be familiar with the appliance use, limitations and associated restrictions. Operating instructions must be read and understood by all persons using or installing this appliance.

Cleanliness of this appliance is essential to good sanitation. Read and follow all included cleaning instructions and schedules to ensure the safety of the food product.

Disconnect this appliance from electrical power before performing any maintenance or servicing.

Do not splash or pour water on, in or over any exposed element, control, control panel or wiring.

DO NOT submerge pre-filter or filter pack in water.

The technical content of this manual, including any wiring diagrams, schematics, parts breakdown illustrations and/or adjustment procedures, is intended for use by qualified technical personnel.

Any procedure which requires the use of tools must be performed by a qualified technician.

This manual is considered to be a permanent part of the appliance. This manual and all supplied instructions, diagrams, schematics, parts breakdown illustrations, notices and labels must remain with the appliance if it is sold or moved to another location.

This appliance is made in the USA. Unless otherwise noted, this appliance has American sizes on all hardware.

PRECAUTIONS AND GENERAL INFORMATION (continued)

OPERATIONAL NOTES:

REPLACE PREFILTER and *REPLACE FILTER PACK* indicator lights provide a timely warning that a system shut-down is imminent.

The actual time between the indicator light coming on and the loss of cooking appliance power will depend upon the cooking conditions.

Anytime a dirty PRE-FILTER is replaced, the system airflow will increase. If the condition of the FILTER PACK is marginal, the REPLACE FILTER PACK light could then come on. If this happens, a fresh FILTER PACK must be installed within a reasonably short time.

Loss of airflow through the old filter pack will soon cause a system shut-down when the airflow falls below minimum vapor capture levels.

KEEP SPARE FILTER PACKS ON HAND.

IMPORTANT: If you decide to “get the most” out of the old filter pack, and continue to use it until a system shut-down happens, it is advisable to have a fresh filter pack readily at hand, and have someone available who is capable of replacing it. Otherwise, you may experience an extended down time, with consequent associated loss of business.

The manufacturer assumes no liability for loss of business due to a system shutdown caused by a dirty pre-filter and/or filter pack (i.e. red *SERVICE REQUIRED* light is on), when the user fails to have the proper replacement pre-filter and/or filter pack on hand. Use only genuine Wells replacement parts and filters, call (800) 264-7827 or your authorized Wells service agent. Parts supplied by others will void your warranty and may not provide safe operation.

The Ventless Cooking System™ hood is designed as part of a **WELLS cooktop appliance** only. No other use of this product is authorized by the manufacturer or its agents. Wells Mfg. assumes no liability for the use of this equipment with products by any other manufacturer's, or for use of this equipment with any Wells Manufacturing product other than in factory certified applications.

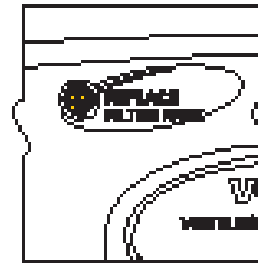
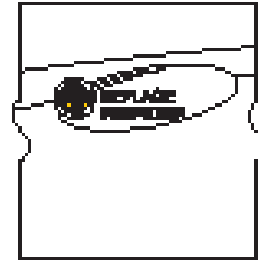



Fig. 5 Ventilator Warning Indicators

AGENCY LISTING INFORMATION

This appliance conforms to NSF Standard 4 for sanitation only if installed in accordance with the supplied *Installation Instructions* And operated and maintained in accordance with the instructions in this manual.

This appliance is  Listed under UL File E146882.



STD 4



E146882



UL710B CATEGORY KNKG
RECIRCULATING SYSTEM
E146887

INSTALLATION

NOTE: DO NOT discard the carton or other packing materials until you have inspected the appliance for hidden damage and tested it for proper operation. Refer to *SHIPPING DAMAGE CLAIM PROCEDURE* on the inside front cover of this manual.



WARNING: RISK OF INJURY

Installation procedures must be performed by a qualified technician with full knowledge of all applicable electrical codes. Failure can result in personal injury and property damage.

UNPACKING & INSPECTION

Carefully remove the appliance from the carton. Remove all protective plastic film, packing materials and accessories from the appliance before connecting electrical power or otherwise performing any installation procedure.

Carefully read all instructions in this manual and the *Installation Instruction Sheet* packed with the appliance before starting any installation.

Read and understand all labels and diagrams attached to the appliance.

Carefully account for all components and accessories before discarding packing materials. Store these components in or near the appliance for later use. To prevent loss, these items should be installed as soon as possible.

1 ea. FIRE SUPPRESSION AGENT (**ANSULEX® Low pH**, 1.5 GAL.)
See Material Safety Data Sheet, page 22.

1 ea. FIRE SUPPRESSION MEDIA TANK

1 ea. FIRE SUPPRESSION TANK CHARGING CARTRIDGE

1 ea. GREASE BAFFLE

1 ea. FILTER PACK ASSEMBLY

1 ea. PRE-FILTER HOLDER with PRE-FILTER

1 ea. GREASE CUP

1 ea. GREASE TROUGH

2 ea. 6" SIDE SPACERS

1 ea. LITERATURE PACKAGE

Additionally:

2 ea. DRAWER INSERTS (if ordered with warmer drawers)

4 ea. HOTPLATE DRIP PANS (if ordered with spiral elements)

4 ea. ELEMENT SUPPORTS (if ordered with spiral elements)

SETUP

Setup the appliance only on a firm level surface. Non-combustible material is recommended.

Refer to the *Installation Instruction Sheet* for required clearances. Maintain required clearances between the appliance and adjacent combustible surfaces. Verify 6" left and right side clearances to combustible construction. This appliance requires a **minimum of 8 ft (96")** (floor to overhead) to allow for adequate exhaust.

Verify that the VENTILATOR HOOD ASSEMBLY is properly and securely assembled to the cooking appliance before beginning the installation procedure.

If a remote manual pull station is to be installed, replace the rear casters with legs.

Level the unit after it is in its final position. Using a spirit level, verify that the unit is level front-to-back and side-to-side.

Avoid storing flammable or combustible materials near the appliance.

INSTALLATION (continued)

SERVICE TECHNICIAN INSTALLATION NOTES

An Ansul® technician must charge and arm the fire suppression system before the ventilator blower will operate. See page 10.

Installation and start up must be performed by an Authorized Installation Company.

Installer must complete the WARRANTY REGISTRATION form, and record appliance installation particulars on the CUSTOMER SERVICE DATA form in this manual.

Certain codes require cooking equipment to be restrained with a RESTRAINT DEVICE. It is the RESPONSIBILITY OF THE INSTALLER to check with the AUTHORITY HAVING JURISDICTION, in order to ascertain the applicability of this requirement to THIS SPECIFIC EQUIPMENT INSTALLATION. Any restraint device must allow access to the back and sides of the unit to provide for servicing and maintenance, and must not interfere with the operation of the FIRE SUPPRESSION SYSTEM.

ELECTRICAL INSTALLATION

Refer to the nameplate on the cooking appliance to verify the ELECTRICAL SERVICE POWER. Voltage and phase must match the nameplate specifications, and available electrical service amperage must meet or exceed the specifications listed on page 1. Incoming wiring must comply with National Electrical Code specifications.

All cooktop / universal hood appliances ship from the factory wired 3ø and include a 3ø cordset.

For 1ø operation:

- a. Remove rear lower panel (item 12)
- b. Refer to the wiring schematic diagram located on the inside of the panel.
- c. Service wiring and conduit, or appropriate cordset must be provided by the electrical installer.
- d. Wiring change must be performed by a licensed electrician.
- e. Be sure to reinstall the panel when wiring change is completed.

IMPORTANT!

Verify that this VENTILATOR and food cooking equipment installation is in compliance with the specifications listed in this manual, with local code requirements, and in accordance with N.F.P.A 96 (THE STANDARD FOR VENTILATION CONTROL AND FIRE PROTECTION OF COMMERCIAL COOKING OPERATIONS - current edition).

THIS IS THE
RESPONSIBILITY OF
THE INSTALLER



DANGER
ELECTRIC
SHOCK
HAZARD

ELECTRIC CONNECTIONS MUST BE MADE BY A LICENSED ELECTRICIAN. Electrical shock will cause death or serious injury.

NOTE: This appliance requires a dedicated 60 Amp electrical branch circuit protection.

IMPORTANT:

Contact a licensed electrician to install and connect electrical power to the appliance.

IMPORTANT:

Damage due to being connected to the wrong voltage or phase is NOT covered by warranty.

INSTALLATION (continued)

DANGER
DANGER
FIRE
HAZARD



THE FIRE SUPPRESSION SYSTEM MUST BE CHARGED AND CERTIFIED BY AN AUTHORIZED ANSUL® DISTRIBUTOR. NEVER ATTEMPT TO MODIFY OR BYPASS THE FIRE SUPPRESSION SYSTEM.

AN UNCONTROLLED FIRE CAN CAUSE SERIOUS INJURY, DEATH AND/OR PROPERTY LOSS.

IMPORTANT: The FIRE SUPPRESSION SYSTEM must be SET-UP and CHARGED by an authorized Ansul® distributor before the ventilator blower will operate.

NOTE: If the fire suppression system is discharged, a buzzer will sound continuously and the cooking appliance will remain inoperable until the fire suppression system is serviced. Recharging and resetting must be performed by an authorized Ansul® distributor ONLY.

Charging of the Ansul Fire Suppression system must be in accordance with Ansul® Design, Installation, Recharge and Maintenance Manual. (Ansul® #418087-05)

FIRE SUPPRESSION SYSTEM INSTALLATION

1. Any REMOTE MANUAL PULL STATION must be installed by an authorized ANSUL® distributor in accordance with the AUTHORITY HAVING JURISDICTION.

NOTE: If a REMOTE MANUAL PULL STATION is installed, moving the unit for servicing will cause the Ansul® system to discharge. In this case, the unit must only be installed with four fixed legs (i.e. remove rear casters and replace with legs). Additional legs may be ordered through an Authorized Wells Service Agency. See page 25.

2. The FIRE SUPPRESSION SYSTEM is comprised of a pressurized cartridge & container of liquid fire suppressant, with associated plumbing and controls. It utilizes factory installed FUSIBLE LINKS for automatic actuation, and a factory installed MANUAL PULL STATION for manual actuation. Two NOZZLES are used to disperse the liquid fire suppression media.

3. When the fire suppression system activates, the fire suppression media is discharged, both the cooking appliance and the ventilator are de-energized, and a buzzer will sound continuously. The fire suppression media will form an emulsion designed to both smother and cool the fire.

Call your Authorized Ansul® Distributor immediately for service.

NOTE: See page 22 for the Material Safety Data Sheet for the fire suppression agent.

4. The MANUAL PULL STATION and any similar REMOTE MANUAL PULL STATION will activate the fire suppression system when the ring on the pull station is pulled horizontally.

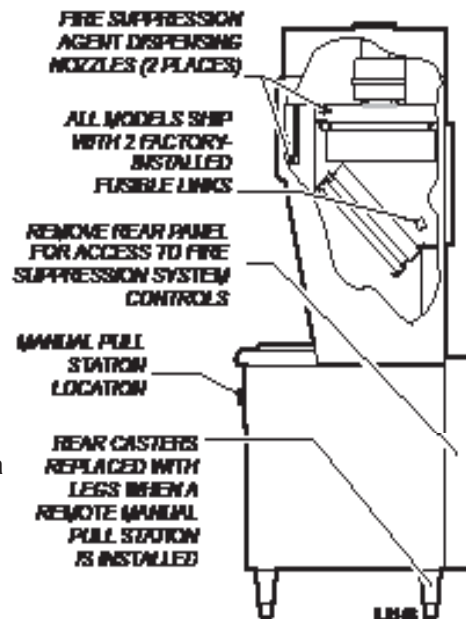

Fig. 6 Fire Suppression System

INSTALLATION (continued)

FILTERS INSTALLATION

1. **FILTER PACK:** Ships installed in the hood. If the **FILTER PACK** is not in position, the **CHECK FILTERS** indicator will light. If the **FILTER PACK** becomes clogged, the **REPLACE FILTER PACK** indicator will glow.

To install the **FILTER PACK**: Position the filter pack with the charcoal portion UP. Slide the filter pack toward the rear of the unit until it contacts the guides on the back panel. Push the filter pack UP into the upper opening until it rests firmly against the filter pack seal. When up in position, holder clips can be snapped over wall ledge on each side. To remove **FILTER PACK**: Grasp both holder clips and pull INWARD until the clips clear the sidewall ledge. Then, pull the filter pack down and out.

2. **PRE-FILTER:** The **PRE-FILTER** ships in the **FILTER FRAME**. If the **PRE-FILTER** is not in position, or if the **PRE-FILTER** is not in the **FILTER FRAME**, the **CHECK FILTERS** indicator will light. If the **PRE-FILTER** becomes clogged, the **REPLACE PRE-FILTER** indicator will glow.

To install the **PRE-FILTER**: Pay attention to the air flow markings. The **AIR FLOW** arrow will point away from the installer. Slide the assembly up into the front opening, behind the upper filter rail. While pressing slightly against the bottom of the assembly, pull the **FILTER HANDLE** toward you so as to engage the **FILTER HOOK** over the lip of the top filter rail. Then lower and seat the assembly into the top indentation of the lower filter rail.

3. **GREASE BAFFLE:** If the **GREASE BAFFLE** is not in place, the **CHECK FILTERS** indicator will glow.

To install the **GREASE BAFFLE**: Slide the grease baffle up into the indentation of the upper filter rail, then lower and seat it into the bottom indentation of the lower filter rail. Pull toward you and downward to verify the **GREASE BAFFLE** is properly seated in the lower frame rail.

NOTE:

The **GREASE BAFFLE** and **FILTER PACK** activate mechanical switches, and the **PRE-FILTER** activates a vacuum switch, to verify that the filter elements are in their proper positions.

All filter elements must be properly installed or the cooktop will not be energized. Also, the **CHECK FILTERS** indicator will light.

IMPORTANT:

The filter hook prevents the **PRE-FILTER** from being drawn in during operation. After installation, press against the top of the filter frame to verify proper engagement of the filter hook over the lip of the top filter rail.

IMPORTANT:

Protect the surface of ceramic cooktops from damage in the event a filter is accidentally dropped. Use only genuine Wells parts and filters, call (800) 264-7827 or your authorized Wells service agent. Parts supplied by others will void your warranty and may not provide safe operation.

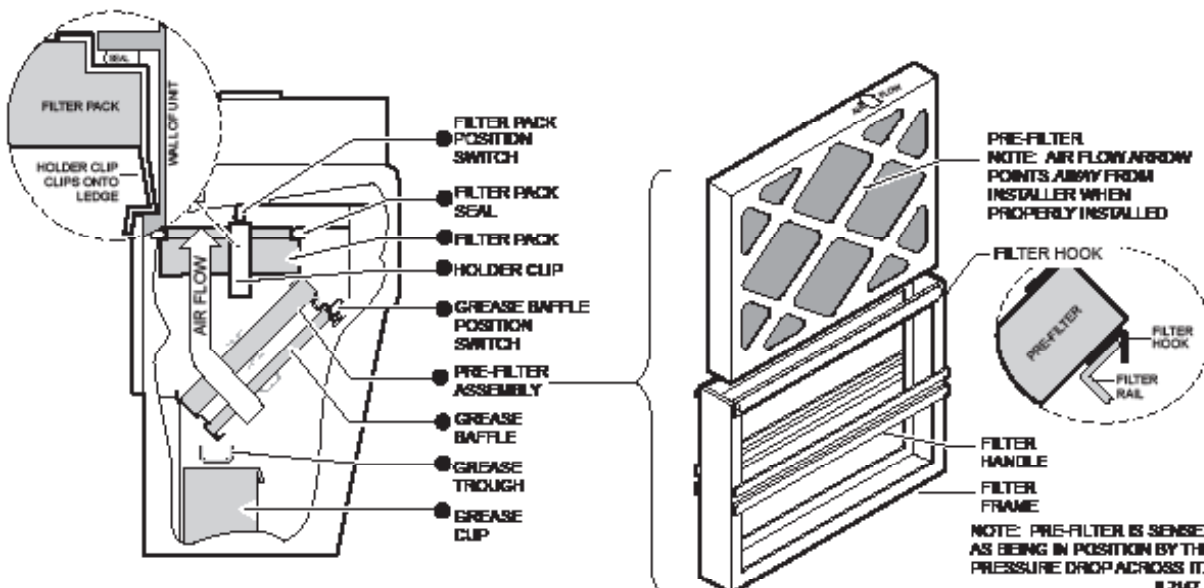

Fig. 7 Filter Installation

INSTALLATION (continued)



WARNING
SLIP / FALL
HAZARD
SPILLED OIL



DO NOT OPERATE UNLESS
THE GREASE CUP IS
INSTALLED.

Oil and moisture will drip onto
the floor and falls may result.
Death or serious injury may
result from slipping and falling



CAUTION:
BURN HAZARD



DO NOT OPERATE UNLESS
GREASE TROUGH IS
INSTALLED.

Moisture will drip into the hot
cooking surface, causing
splattering of hot liquids.
Serious injury can result from
contact with hot splatter.

GREASE TROUGH AND GREASE CUP INSTALLATION

1. Install the GREASE TROUGH into the brackets below the grease baffle.
2. Install the GREASE CUP on the right side of the unit, directly below the grease trough.

ROLL WARMER INSTALLATION

1. Be sure roller catches (inside warmer cavity) are in the open position. Install drawer assemblies in drawer slides.
2. Place appropriate one drawer insert pan into each warmer drawer. If used, place one Humitrol rack into each drawer pan.

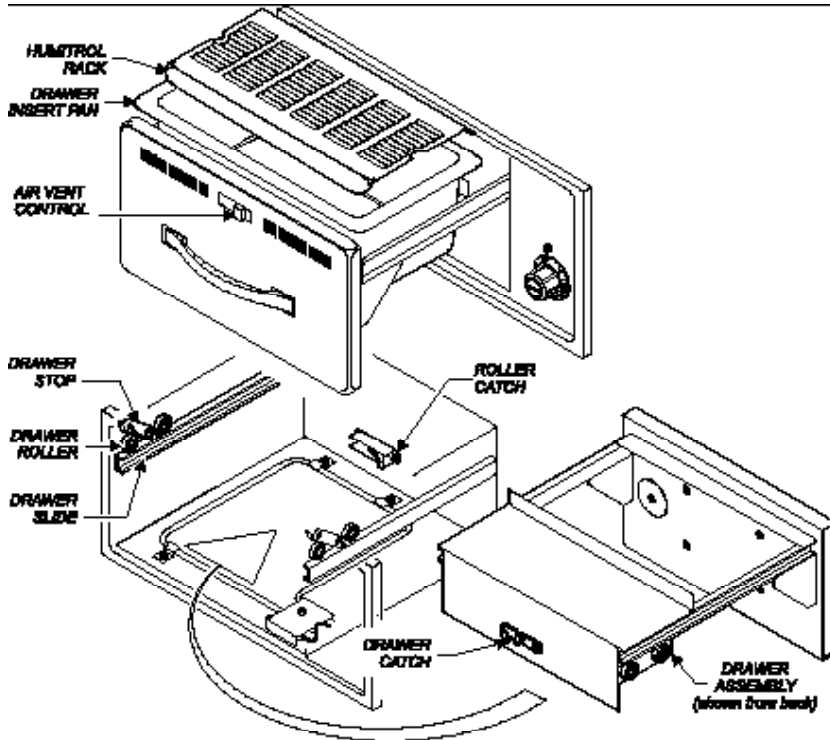

Fig. 8 Roll Warmer Drawer Pan Installation

OPERATION

VENTILATOR OPERATION

1. Press the VENTILATOR POWER switch to ON. The green VENTILATOR POWER light will glow and the blower fan will start. After a short time, if all filters are sensed as being in position and not clogged, the cooktop will be energized. The roll warmer is energized at all times. During normal operation, the VENTILATOR POWER light will be the only light glowing on the upper control panel.
2. If the amber CHECK FILTER light glows, one or more filter elements is out of position. Check the GREASE BAFFLE, PRE-FILTER and FILTER PACK for proper installation in their respective positions. Grease baffle and filter pack position are sensed by mechanical switches. Pre-filter position is sensed by a vacuum switch.
3. When the amber REPLACE PRE-FILTER light glows, the pre-filter is nearing the end of its service life. Replace the disposable PRE-FILTER ELEMENT.
4. When the amber REPLACE FILTER PACK light illuminates, the HEPA / Charcoal filter pack is nearing the end of its service life. Replace the filter pack.

Note: The REPLACE PRE-FILTER and REPLACE FILTER PACK lights are a warning that the indicated filter is near the end of its service life. The appliance will continue to operate for a period of time after the light glows to allow continued operation through a peak period. However, the indicated filters must be replaced within a reasonably short time period or they will clog and shut down electrical power to the cooktop. The ventilator blower will continue to run.

5. When the red SERVICE REQUIRED light glows, either the pre-filter or filter pack (or both) is clogged and can no longer pass sufficient air to allow further operation. The ventilator fan continues to run, but the cooktop is shut down until the underlying clogged filter situation has been corrected. This can occur when neither CHANGE...FILTER indicator light is lit, if both pre-filter and filter pack are marginal. Replacing both the pre-filter and the filter pack will remedy the situation.

Note: replacing the pre-filter, even though not very dirty, will often extend the service life of the more expensive filter pack.

Reset the unit by turning the VENTILATOR POWER switch to OFF, then back ON.

6. A failure of incoming electrical power will cause a shut down of the unit. After power is restored, reset the unit by turning the VENTILATOR POWER switch to OFF, then back ON.



CAUTION: HOT SURFACE

Exposed surfaces can be hot to the touch and may cause burns.

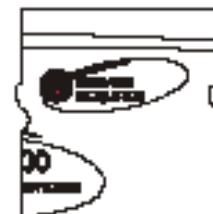
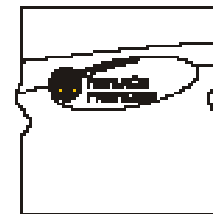
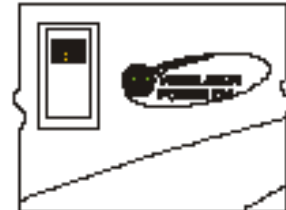

Fig. 9 Ventilator Indicator and Warning Lights

OPERATION (continued)



CAUTION: HOT SURFACE

Exposed surfaces can be hot to the touch and may cause burns.

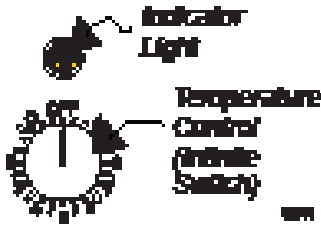

Fig. 10 Hotplate Temperature Control

IMPORTANT:

The dial markings are an INDICATION of temperature only. The temperature of the food product depends on many factors, including the size, shape and material of the food container, and the quantity and consistency of the food product.

HOTPLATE COOKTOP OPERATION

GENERAL OPERATIONAL NOTES

Carefully read the description of the hotplate operation on the specification sheet.

DO NOT attempt to perform any maintenance or service unless the hotplate is disconnected from electrical power.

DO turn the circuit breaker for the hotplate off before cleaning, servicing or performing any maintenance.

DO NOT use sharp objects or metal implements to clean the heating elements.

DO use a plastic spatula or plastic scouring pad to remove burned-on food product.

OPERATION

Each heating element is controlled by an infinite switch temperature control:

OFF removes power from the element

LOW thru 8 are temperature settings

Higher numbers indicate higher temperatures

There is a continuous range of settings between LOW and HI

HI is a continuous ON setting

The indicator light will glow any time the temperature control is on.

On ceramic cooktops, the HOT SURFACE indicator will glow any time the control is on, or the surface is above 150°F.

Cooking Recommendations:

Save energy by turning the temperature control off any time the hotplate is not in use. The coil-type and ceramic heating elements will provide full heat within 30 seconds, while solid plate heating elements will reach full heat within 2 minutes, making it unnecessary to leave the unit on during intermittent use.

Each heating element can hold up to a 16 quart pot or pan. For efficient heating of food product, pots and pans should be no more than 10" in diameter.

Maximize the efficiency of solid elements and ceramic cooktops by using flat-bottom pots and pans.

Stir thick liquids frequently to maintain a consistent temperature.

OPERATION (continued)

DRAWER WARMER OPERATION

HEATING OPTIONS

1. Moist heat with Humitrol Rack:
 - a. MOIST operation prevents food from drying out as moisture, as well as heat, is applied to the warming chamber.
 - b. To set for MOIST operation, remove Humitrol Rack from bottom of drawer insert pan and carefully pour approximately 2 quarts of water (½" depth) into the pan. Reinstall rack.
 - c. The Humitrol Rack decreases the sloshing effect of the water in the pan when the drawer is opened. When the drawer is closed, the Humitrol Rack allows steam to rise through the stored product in the drawer.
 - d. Place the food directly on the rack. The rack is designed to support the food off of the steam vents, where water droplets may form.
 - e. Check the water level in the pan periodically, and add water when necessary.
 - f. Set the front air vent between fully closed and half-open. Actual setting will depend upon the type and amount of product stored in the drawer, the temperature setting, and the frequency with which the drawer is opened.
2. Moist heat with pans:
 - a. This Wells warmer is designed to accommodate any combination of standard-size, steam table pans.
 - b. Place a small amount of water in drawer pan. Place pans in drawer pan.
 - c. Check the water level in the pan periodically, and add water when necessary.
3. Dry heat:
 - a. For some applications, you may want to store previously prepared foods in a dry-heat environment. To do so, place the food directly into the empty (i.e. no water) drawer pan.



**CAUTION:
HOT SURFACE**

Exposed surfaces can be hot to the touch and may cause burns.

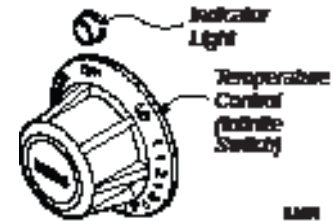

Fig. 11 Roll Warmer Temperature Control

NOTE:

The chart below is intended as a guide ONLY. Your own experience with this appliance, type of foods and method of operation will enable you to determine the temperature control and air vent settings best suited to your operation.

OPERATING CHART FOR DRAWER WARMERS

PRODUCT TYPE	RECOMMENDED STORAGE TEMP.	TYPE OF HEAT	CONTROL SETTING	AIR VENT SETTING
Hard Rolls	160-185°F	Dry	7-8	Closed
Soft Rolls	150-175°F	Moist	6-7	Open - ½
Vegetables	175-185°F	Moist	7-8	Open - ½
Meats	165-185°F	Dry	6-8	Closed
Fish	165-185°F	Moist	6-8	Open
Casseroles	150-175°F	Dry	6-7	Closed
Pies, Desserts	160-185°F	Dry	6-7	Closed

OPERATION (continued)

DRAWER WARMER OPERATION (when provided)

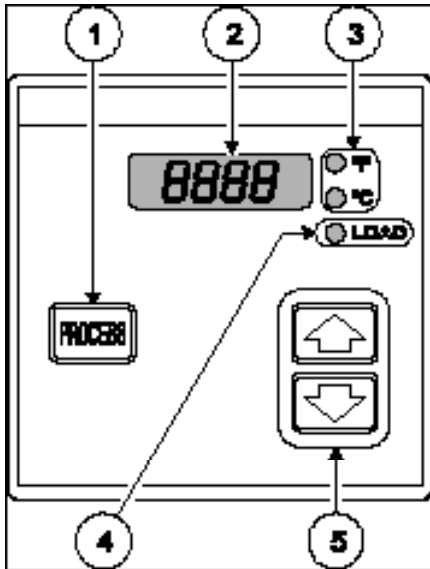

ITEM	DESCRIPTION
1	PROCESS Key: Press to view actual temperature of cavity.
2	4 Character LED Display: Normally shows SETPOINT temperature.
3	°F or °C Indicator: Glow to indicate if unit is configured for degrees Fahrenheit or degrees Celsius.
4	LOAD Indicator: Glow when heating element is energized.
5	Increment and Decrement Keys: Press UP arrow to increase Press DOWN arrow to decrease

RWT- CONTROL MODULE

SET SETPOINT TEMPERATURE

Press an arrow key:
UP arrow to increase
DOWN arrow to decrease

Release key when desired setpoint temperature is displayed.

Reading is locked into memory 3 seconds after last key stroke.

Minimum setpoint is 140°F (60°C)

Maximum setpoint is 250°F (121°C)

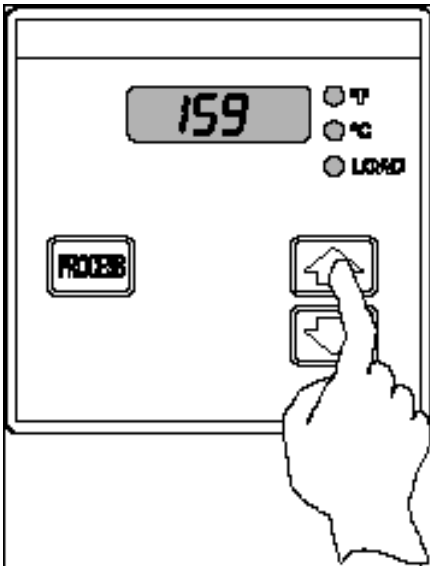

CHANGE DISPLAY MODE (°F or °C)

Press and hold UP arrow and DOWN arrow keys for 10 seconds.

Release keys when display reads F C.

Within 3 seconds, press UP arrow or DOWN arrow key until desired indicator (°F or °C) glows.

The new value will lock into memory 3 seconds after last keystroke.

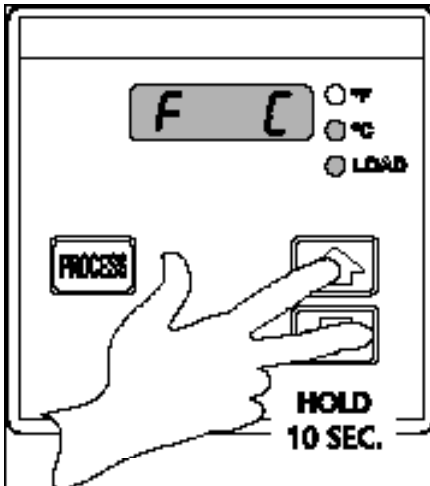

CLEANING INSTRUCTIONS

HOTPLATE COOKTOP DAILY CLEANING

PREPARATION	Disconnect appliance from electric power Allow to cool before cleaning
FREQUENCY	Daily
TOOLS	Warm water and a mild detergent Soft clean cloth or sponge Plastic scouring pad, plastic scraper



CAUTION: ELECTRIC SHOCK HAZARD

Disconnect appliance from electric power before cleaning.



CAUTION: HOT SURFACE

Exposed surfaces can be hot to the touch and may cause burns. Allow appliance to cool before cleaning.

Disconnect appliance from electric power
Allow to cool before cleaning

Spiral Hotplate Elements:

Raise elements. Remove and empty drip pans.

Drip pans and element supports may be washed in a sink or dishwasher. Allow to air dry and reinstall.

Scrape burned-on food debris from element using a plastic scraper or plastic scouring pad. DO NOT use steel wool or metal implements to clean elements.

Solid Plate Hotplate Elements:

Scrape burned-on food debris from element using a plastic scraper or plastic scouring pad. DO NOT use steel wool or metal implements to clean elements.

Wipe elements and counter top with a clean cloth or sponge dampened with warm water and a mild detergent. Rinse by wiping with a clean cloth or sponge dampened with warm water. Allow to air dry.

Procedure is complete.

IMPORTANT:

DO NOT spill or pour water into controls, control panel, wiring or coil-type hotplate elements. Damage to internal components will occur. Damage to internal components from water damage is **not** covered by warranty.

IMPORTANT:

DO NOT use steel wool or metal implements to clean hotplate elements.

CLEANING INSTRUCTIONS (continued)



CAUTION: ELECTRIC SHOCK HAZARD

Disconnect appliance from electric power before cleaning.



CAUTION: HOT SURFACE

Exposed surfaces can be hot to the touch and may cause burns. Allow appliance to cool before cleaning.

IMPORTANT:

Never allow PRE-FILTER or FILTER PACK to get wet. DO NOT wash either of these two filters. Washing these filters will ruin them and cause the appliance to shut-down.

IMPORTANT:

DO NOT spill or pour water into controls, control panel, wiring or coil-type hotplate elements. Damage to internal components will occur. Damage to internal components from water damage is **not** covered by warranty.

IMPORTANT:

DO NOT use steel wool or metal implements to clean cabinet surfaces.

VENTILATOR WEEKLY CLEANING

PREPARATION: Disconnect appliance from electric power
Allow to cool before cleaning

FREQUENCY: Weekly

TOOLS: Warm water and a mild detergent
Soft clean cloth or sponge
Bristle brush
Container for disposal of grease

1. Remove the grease baffle, pre-filter assembly, grease trough and grease cup. Empty the grease trough and grease cup.
2. Remove the pre-filter from the filter frame. Wash and rinse the filter frame ONLY.
3. Wash and rinse the grease baffle, grease trough and grease cup in a sink or dishwasher using mild detergent and warm water. Allow to air dry.
4. Reinsert the pre-filter into the filter frame. Reinstall the pre-filter, grease baffle, grease trough and grease cup.

Procedure is complete

CLEANING INSTRUCTIONS (continued)

VENTILATOR MONTHLY CLEANING

PREPARATION:	Disconnect appliance from electric power Allow to cool before cleaning
FREQUENCY:	Monthly
TOOLS:	Warm water and a mild detergent Soft clean cloth or sponge Plastic scouring pad, plastic scraper Container for disposal of grease



CAUTION: ELECTRIC SHOCK HAZARD

Disconnect appliance from electric power before cleaning.



CAUTION: HOT SURFACE

Exposed surfaces can be hot to the touch and may cause burns. Allow appliance to cool before cleaning.

EXTERIOR

Wash exterior surfaces with a soft clean cloth or sponge dampened with warm water, mild soap or detergent. Rinse with a soft clean cloth or sponge dampened with warm water. Allow to air dry.

INTERIOR:

In addition to the weekly cleaning procedure, remove the filter pack.

Cover the griddle section. Wash the interior surfaces of the ventilator with warm water, mild soap or detergent and a clean, soft cloth or sponge. Stubborn or burned-on food debris may be removed with a plastic scouring pad or plastic scraper.

Dry thoroughly with a clean soft cloth.

Uncover the griddle and reassemble the ventilator.

Procedure is complete.

IMPORTANT:

Never allow PRE-FILTER or FILTER PACK to get wet. DO NOT wash either of these two filters. Washing these filters will ruin them and cause the appliance to shut-down.

IMPORTANT:

DO NOT spill or pour water into controls, control panel, wiring or coil-type hotplate elements. Damage to internal components will occur. Damage to internal components from water damage is **not** covered by warranty.

IMPORTANT:

DO NOT use steel wool or metal implements to clean cabinet surfaces.

CLEANING INSTRUCTIONS (continued)



CAUTION: ELECTRIC SHOCK HAZARD

Disconnect appliance from electric power before cleaning.



CAUTION: HOT SURFACE

Exposed surfaces can be hot to the touch and may cause burns. Allow appliance to cool before cleaning.

IMPORTANT:

DO NOT spill or pour water into controls, control panel, wiring or coil-type hotplate elements. Damage to internal components will occur. Damage to internal components from water damage is **not** covered by warranty.

IMPORTANT:

DO NOT use steel wool or metal implements to clean drawers or cabinet surfaces.

DRAWER WARMER DAILY CLEANING

PRECAUTIONS: Turn control knob to OFF.
Allow drawers to cool before proceeding.
Remove drawer pans and Humitrol racks.

FREQUENCY: Minimum -Daily

TOOLS: Warm water and mild detergent
Clean cloth or sponge

1. Remove drawers from warmer:
 - a. Pull warmer drawer out until fully extended.
 - b. Slide finger along left and right slide rail until you reach the latches (located at the front end of the cabinet-mounted rails) Press down on both left and right latch.
 - c. Pull drawer away from warmer.

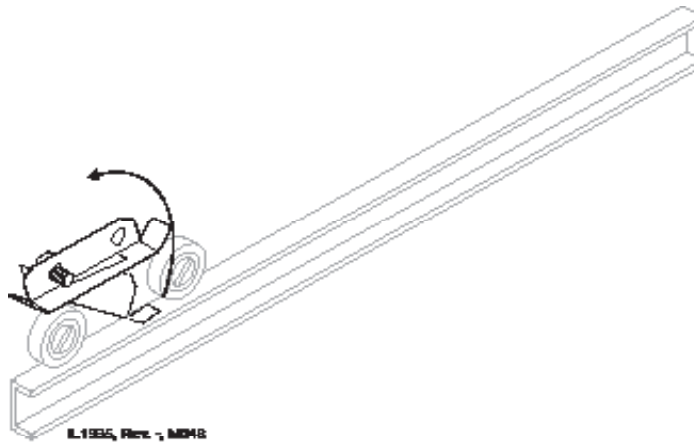

2. Clean drawers, drawer pans, Humitrol Racks and/or insets with warm water and mild detergent. Rinse all components thoroughly with clear water. Dry all components prior to reinstalling them in warmer.
3. Sweep crumbs and other debris from warmer cavity.
4. Clean the outside of the unit by wiping with a clean cloth or sponge, warm water and mild detergent. Dry with a clean cloth, then wipe with a polish formulated for stainless steel.
5. It is important to keep the slide rails clear and free from debris. Periodic cleaning of the slide rails and other adjoining parts is necessary to assure smooth drawer operation.
6. Check drawer rollers. Be sure they roll freely and that the slide rails are free from debris.
7. Be sure cabinet-mounted drawer catch roller is "up", then re-install drawers.

MAINTENANCE SCHEDULES

1. 6-MONTH MAINTENANCE (MUST BE PERFORMED BY AN AUTHORIZED ANSUL® DISTRIBUTOR ONLY):
 - a. Inspect and test total operation including FIRE DAMPER and all SAFETY INTERLOCKS.
 - b. All FIRE SUPPRESSION SYSTEM actuation components including MANUAL PULL STATION and any REMOTE MANUAL PULL STATION must be inspected for proper operation in accordance with the maintenance schedule published in ANSUL® R-102 SYSTEM DESIGN, INSTALLATION, RECHARGE AND MAINTENANCE MANUAL (Ansul® #418087-05).
 - c. The FIRE SUPPRESSION SYSTEM FUSIBLE LINKS must be inspected. NOZZLES and MANUAL PULL STATION must be cleaned in accordance with ANSUL® R-102 SYSTEM DESIGN, INSTALLATION, RECHARGE AND MAINTENANCE MANUAL (Ansul® #418087-05).
 - d. The FIRE SUPPRESSION AGENT TANK, PIPING and FLEXIBLE TUBING must be INSPECTED.
2. 12-YEAR MAINTENANCE: (MUST BE PERFORMED BY AN AUTHORIZED ANSUL® DISTRIBUTOR ONLY):
 - a. The FIRE SUPPRESSION AGENT TANK and ¼" FLEX HOSE must be HYDROSTATICALLY TESTED, and the FIRE EXTINGUISHING AGENT must be REPLACED in accordance with the maintenance schedule published in ANSUL® R-102 SYSTEM (STANDARD UL 300 LISTED).
 - b. The FUSIBLE LINKS in plenum and damper must be REPLACED. This maintenance to be performed by qualified Ansul® service personnel only.

USE AND MAINTENANCE SHALL BE IN ACCORDANCE WITH THE STANDARD FOR VENTILATION CONTROL AND FIRE PROTECTION OF COMMERCIAL COOKING OPERATIONS, N.F.P.A 17A & N.F.P.A. 96 (current editions).



**DANGER
FIRE
HAZARD**

FAILURE TO PROPERLY CLEAN AND MAINTAIN THIS EQUIPMENT CAN CAUSE A FIRE. AN UNCONTROLLED FIRE CAN CAUSE SERIOUS INJURY, DEATH AND/OR PROPERTY LOSS.

NOTE: A signed and dated VENTILATOR HOOD MAINTENANCE LOG must be maintained on the premises, and shall be available for inspection by the authority having jurisdiction. See pages 20 & 21.

IMPORTANT: Parts used for the Ansul® fire suppression system are not serviceable by the owner / operator. Procedures for servicing fire suppression equipment are described in:

ANSUL® R-102 SYSTEM DESIGN, INSTALLATION, RECHARGE AND MAINTENANCE MANUAL (Ansul® #418087-05).

Inspection shall be conducted on a monthly basis in accordance with the manufacturer's Operation Manual. At a minimum, this inspection shall include verification of the following:

WELLS BLOOMFIELD, LLC
VENTILATOR HOOD OWNERS' MONTHLY INSPECTION LOG

OPERATION	AGENT / DATE											
Exhausting system components: In proper place and (visually) in good order												
Manual pull station actuators for fire suppression system are unobstructed												
The maintenance log is in place and up to date												
No obvious physical damage or condition exists that might prevent operation of fire fire suppression system												
The nozzles blow-off caps are in place and in good condition												
The hood, duct and protected cooking appliances have not been replaced, modified or retrofitted												
Check PLATEM GREASE BAFFLE and BLOWER (max. interval: 3 months)												
Change PRE-FILTER and FILTER PACK (as required)												

LPH

This MAINTENANCE LOG is to be performed and completed by a trained technician who has completed the instruction necessary to perform the maintenance and recharge services.

**WELLS BLOOMFIELD, LLC
VENTILATOR HOOD MAINTENANCE LOG**

OPERATION		AGENT / DATE																				
Clean and inspect discharge nozzle in plenum BEFORE filters Max. Interval: 6 months																						
Clean and inspect discharge nozzle in plenum AFTER filters Max. Interval: 6 months																						
Inspect fire suppression lines links, all releasing devices for activation, fire suppression tank liquid level Max. Interval: 6 months (discharge of fire suppression not a part of this test)																						
Inspect fire suppression hoses, plumbing and tank for obstructions and any conditions such as, but not limited to, corrosion and pitting. Max. Interval: 6 months																						
Inspect and test all filter inlets/outlets Max. Interval: 6 months																						
Replace two (2) fire suppression links in cooking appliance: each link is rated @ 165°F	Log TEMP																					
	Log Mfg DATE Stamp																					
Max. Interval: 12 months																						
Replace fire damper fusible link: rated @ 280°F	Log TEMP																					
	Log Mfg DATE Stamp																					
Max. interval: 12 months																						

THIS MAINTENANCE LOG MUST BE KEPT IN A PROTECTIVE COVER PERMANENTLY ATTACHED TO THE APPLIANCE
Log all repairs and recommendations on reverse side. Any repairs, other than replacement of factory authorized parts, to the fire suppression plumbing system must be subject to hydrostatic pressure testing.

ANSULEX Low pH

DUPLICATE IDENTIFIER (if Part Common Name)

Name of Manufacturer	ANSUL INCORPORATED	Emergency Telephone No.	CHEMTREC (800) 424-9300 or (703) 527-3887
Address	One Stanton Street, Marinette, WI 54143-2542	Other Information Cont.	(715) 735-7411
Prepared By	Safety and Health Department	Date Prepared	February 1, 1999

SECTION 1 - IDENTITY

Common Name (Use or Label) (If Name is not a Synonym)	ANSULEX Low pH Liquid Fire Suppressant	CAS No.	N/A
Chemical Name	N/A This is a Mixture	Chemical Family	Mixture
Formula	N/A		

SECTION 2 - INGREDIENTS

TABLE A - HAZARDOUS INGREDIENTS				
Principal Hazardous Component (if Name is not common name)	Wt. %	CAS No.	ACGIH TLV	Acute Toxicity Data
None	N/A	N/A	N/A	N/A
TABLE B - OTHER INGREDIENTS				
Other Component (chemical or common name)	Wt. %	CAS No.	ACGIH TLV	Acute Toxicity Data
Proprietary Mixture of Organic and Inorganic Salts	48.0 - 50.0	N/A	NE	NDA
Phosphoric Acid	0.2	7664-38-2	NE	NDA
EDTA	0.65	64-02-8	NE	NDA
Yellow-Green Fluorescent Dye	0.011	518-47-8	NE	Oral LD ₅₀ (rat) 6800 mg/kg
Water	Approx. 50.0	7732-18-5	NE	NDA

SECTION 3 - PHYSICAL AND CHEMICAL CHARACTERISTICS (Fire and Explosion Data)

Boiling Point	113°C	Specific Gravity (20-15)	1.33	Vapor Pressure (mm Hg)	Not Determined
Percent Volatile by Volume (%)	Approx. 50.0	Vapor Density (Air = 1)	1.03	Lower Explosive Limit (by Volume - L)	Approx. 0.005
Solubility in Water	100%	Reactivity with Water	Mild exothermic reaction		
Appearance and Odor	Fluorescent Yellow Colored Liquid, Mild Odor				
Flash Point	None to boiling	Flammable Limits (Air % by Volume)	N/A	Extinction Media	N/A
Auto-ignition Temperature	N/A				
Special Fire Fighting Procedures	NONE - THIS IS AN EXTINGUISHING AGENT				
Unusual Fire and Explosion Hazards	None				

SECTION 4 - PHYSICAL HAZARDS

Stability	Unstable <input type="checkbox"/> Stable <input checked="" type="checkbox"/>	Corrosive to Skin	N/A
Incompatibility (Material to Avoid)	Reactive Metals, ClF ₄ , electrically energized equipment, any material reactive with water.		
Hazardous Decomposition Products	Not established, acid fumes.		
Hazardous Polymerization	May Occur <input type="checkbox"/> Will Not Occur <input checked="" type="checkbox"/>	Corrosive to Skin	N/A

M504 p/n 2M-303903 Owners Manual WV-4H Ventless Hooplate Cooktop

SECTION 5 - HEALTH HAZARDS

ANSULEX Low pH (continued)

Threshold Limit Value	None Established		
Routes of Entry, Eye Contact	Irritant		
Skin Contact	Irritant		
Inhalation	Not an expected route of entry. Can be irritating to mucous membranes.		
Ingestion	Irritating to mucous membranes. Acute Oral LD ₅₀ (Sprague-Dawley rats) 825.5mg/kg.		
Signs and Symptoms	Acute Exposure: Material irritates skin, eyes, and mucous membranes. Chronic Exposure: None known.		
Health Considerations (Overall) Aggravated by Exposure	None known.		
Chemical Listed as Carcinogen or Potential	National Toxicology Program: Yes <input type="checkbox"/> No <input checked="" type="checkbox"/>	IARC Monographs: Yes <input type="checkbox"/> No <input checked="" type="checkbox"/>	OSHA: Yes <input type="checkbox"/> No <input checked="" type="checkbox"/>

SECTION 6 - EMERGENCY AND FIRST AID PROCEDURES

Eye Contact	Flush and irrigate with water for 15 minutes while holding eyelids open. If irritation persists, seek medical attention.
Skin Contact	Wash thoroughly with soap and water. If irritation persists, seek medical attention.
Inhalation	Fresh air if symptoms occur. If irritation persists, seek medical attention.
Ingestion	Dilute by drinking large quantities of water.

SECTION 7 - SPECIAL PROTECTION INFORMATION

Respiratory Protection (Specify Type)	N/A		
Ventilation	Local Exhaust: N/A	Mechanical (General)	N/A
Protective Clothing	Rubber gloves for spill/leak	Eye Protection	Chemical goggles recommended during spill/leak procedures.
Other Protective Clothing or Equipment	Eye wash and safety showers are good safety practice.		

SECTION 8 - SPECIAL PRECAUTIONS AND SPILL/LEAK PROCEDURES

Precautions to be taken in Handling and Storage	Store in original container. Keep tightly closed. Keep separate from acid.
Other Precautions	See incompatibility information in Section 4.
Steps to be taken in Case of Material Release or Spill	Stop leaks. Contain spills. Remove as much as possible. Place in closed container for proper disposal. Wash spill area with large amounts of water to remove traces and neutralize.
Methods of Disposal	Dispose of in compliance with local, state and federal regulations.

HAZARDOUS MATERIAL IDENTIFICATION SYSTEM

HAZARD INDEX	
4 SEVERE HAZARD	1 HEALTH
3 SERIOUS HAZARD	2 FLAMMABILITY
2 MODERATE HAZARD	3 REACTIVITY
1 SLIGHT HAZARD	
0 MINIMAL HAZARD	

N/A = Not Applicable NDA = No Data Available N/E = Not Established

ANSULEX is a registered trademark.

© 1995 Ansulex Corporation

ANSULEX CORPORATION, ONE STATION STREET, NARWELI, WI 54143-3543

Form No. F-58188-B

© 1995 Ansulex Corporation

M504 p/n 2M-303903 Owners Manual WV-4H Ventless Hotplate Cooktop

TROUBLESHOOTING SUGGESTIONS

SYMPTOM	POSSIBLE CAUSE	SUGGESTED ACTION
Ventilator blower won't run	Circuit breaker tripped	Check / reset circuit breaker
Ventilator blower won't run — buzzer sounding	Ansul® fire suppression system tripped	Contact Authorized Ansul® Distributor for repairs
Ventilator blower runs momentarily, shuts down.	Clogged filter, or filter out of position	Observe indicator lights, service filter(s) as required
	Damaged internal components	Contact your Authorized Wells Service Agent for repairs
<i>CHECK FILTERS</i> light on	Filter or grease baffle out of position	Reinstall filters / baffle
<i>REPLACE PREFILTER</i> light on.	Pre-filter clogged, but still operational	Replace pre-filter at first opportunity
<i>REPLACE FILTER PACK</i> light on	Filter pack clogged, but still operational	Replace filter pack at first opportunity
SERVICE REQUIRED light on	Pre-filter or filter pack clogged	Replace pre-filter first. If indicator stays lit, replace filter pack
Cooktop won't heat	Ventilator not operational	See above
	Temperature control not set	Set control to desired temp
	Damaged internal components	Contact your Authorized Wells Service Agent for repairs
One or more cooktop sections not hot enough	Temperature control not set	Set control to desired temp
	204V unit run on 208V	Contact your Authorized Wells Service Agent for conversion
Roll warmers won't heat (ventilator operational)	Damaged internal components	Contact your Authorized Wells Service Agent for repairs
	Damaged internal components	Contact your Authorized Wells Service Agent for repairs
Warmer drawer not hot enough	Temperature control not set	Set control to desired temp
Product in warmer drawer too dry or wet	Humidity control not set	Set for desired humidity

NOTE: There are no user serviceable components in the appliance.

- A. In all cases of damage or component malfunction, contact your Authorized Wells Service Agency for repairs.
- B. For service of the fire suppression system, contact an Authorized Ansul® Distributor.

PARTS BREAKDOWN for ANSUL® COMPONENTS

FOR USE ONLY BY AUTHORIZED ANSUL® SERVICE PERSONNEL

Refer to Ansul® part no. 418078-05
R-102 Restaurant Fire Suppression
System Design, Installation,
Recharge and Maintenance

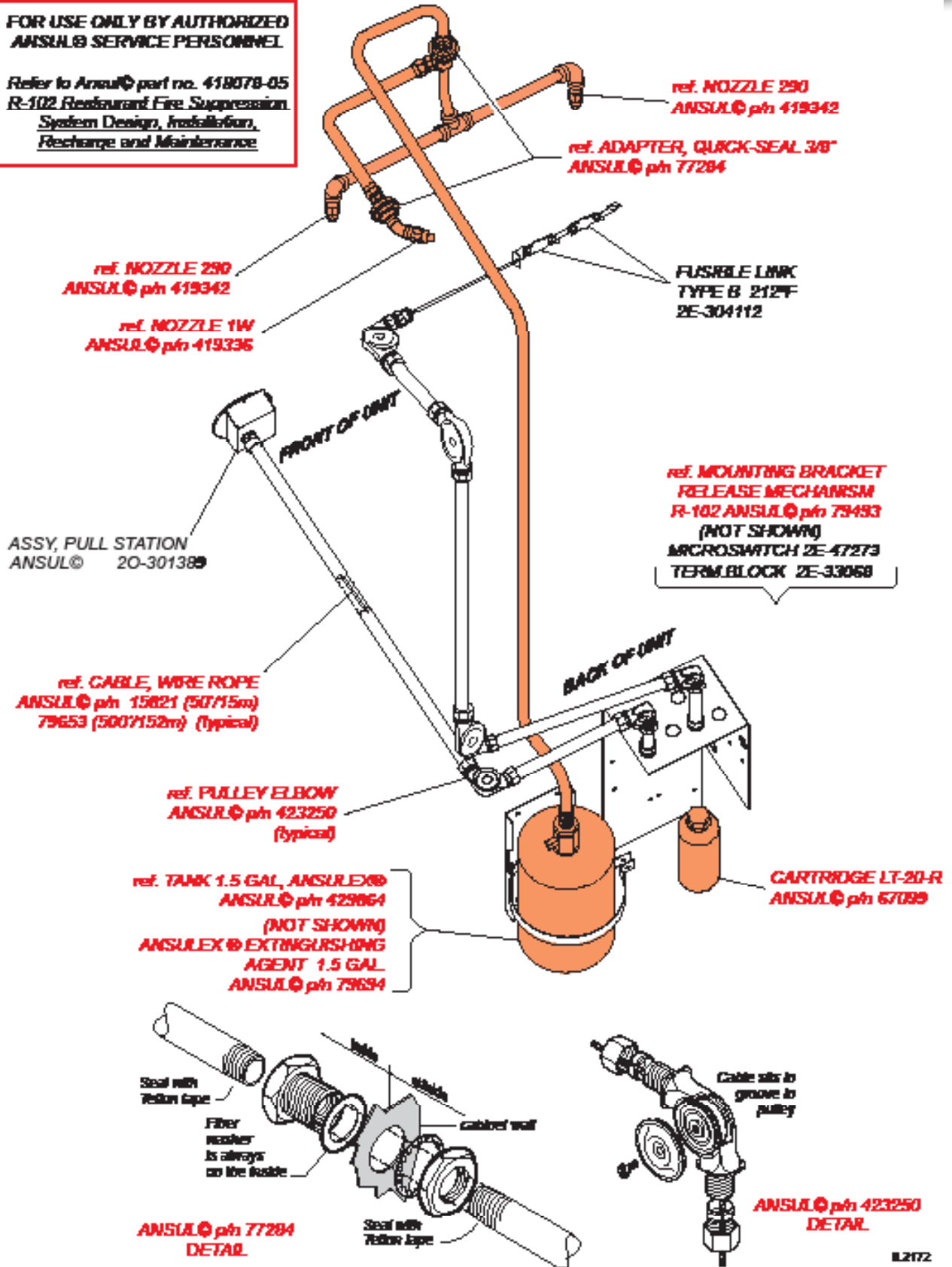

IL2172

EXPLODED VIEW & PARTS LIST

HOOD CABINET COMPONENTS

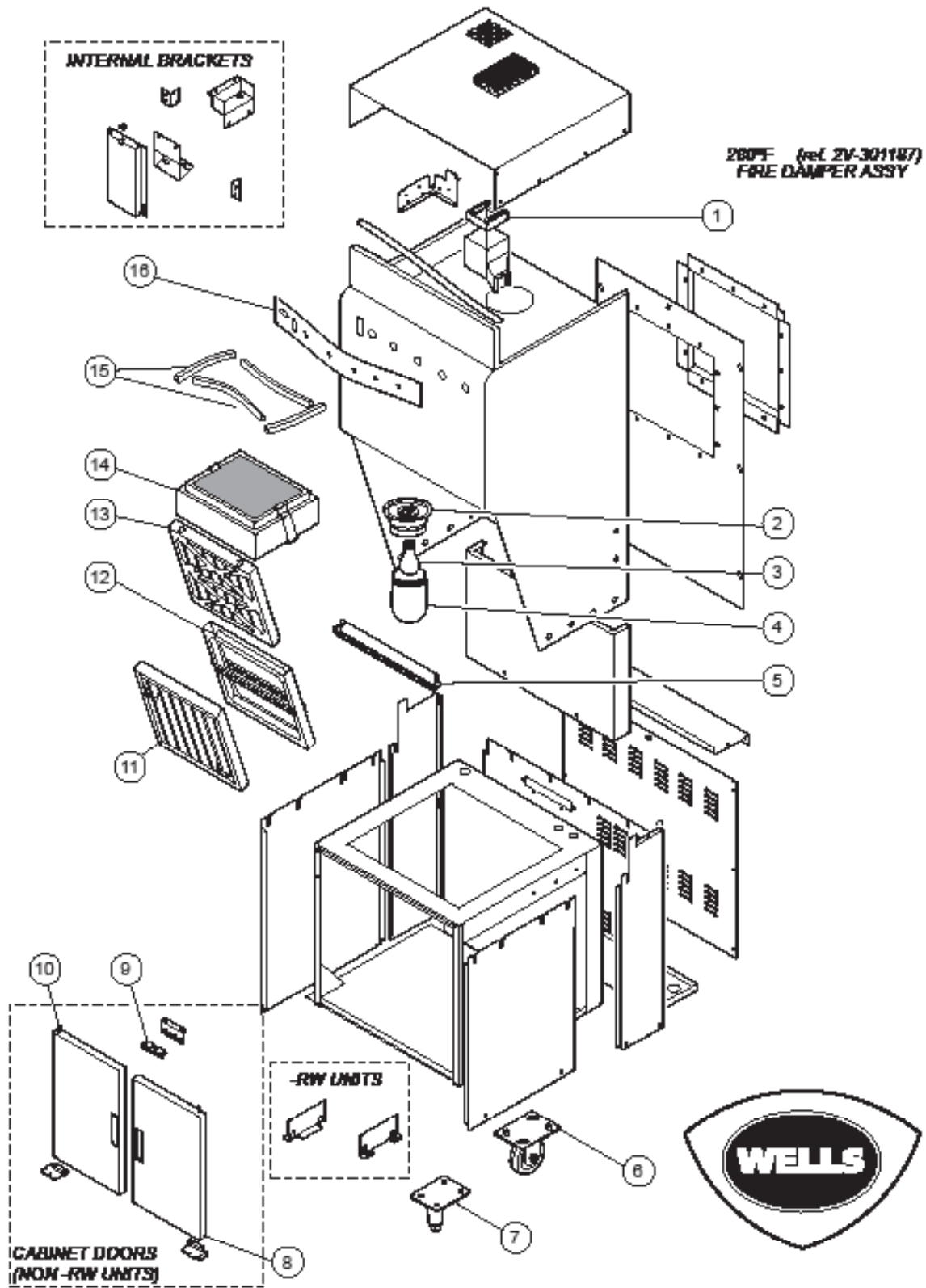

WV4H; Hood Cabinet Components

L2173a

EXPLODED VIEW & PARTS LIST

HOOD CABINET COMPONENTS

Model: WV4H Hood Cabinet Components			
Fig No.	Part No	Description	Application
1	2V-301187	DAMPER	
2	2E-305098	LIGHT HOUSING VCS HOOD NEW	
3	2S-305100	LIGHT BULB/100W-230V, FROSTED	
4	2Q-305099	GLASS GLOBE VCS HOOD	
5	M3-304405	TRAY GREASE DRIP HOOD	
6	5E-20804	CASTER ASSY 2FIX, 2SWVL	
7	5M-22649	KIT LEG REAR OPT WVF/WVG	
8	M3-302646	DOOR ASSY RIGHT	
9	2R-46502	MAGNET DOOR	
10	M3-302642	DOOR ASSY LEFT	
11	2I-302580	FILTER BAFFLE	
12	M3-302688	PREFILTER CAGE	
13	2I-302579	FILTER PRE HOOD UNIVERSAL	
14	M3-302775	FILTERPACK ASSY UNIV HOOD	
15	1P-302749	TAPE SILICONE GRAY	Sold by the foot
16	2M-302782	FACEPLATE FRONT PNL UNIV.	

EXPLODED VIEW & PARTS LIST

HOOD ELECTRICAL & VACUUM COMPONENTS

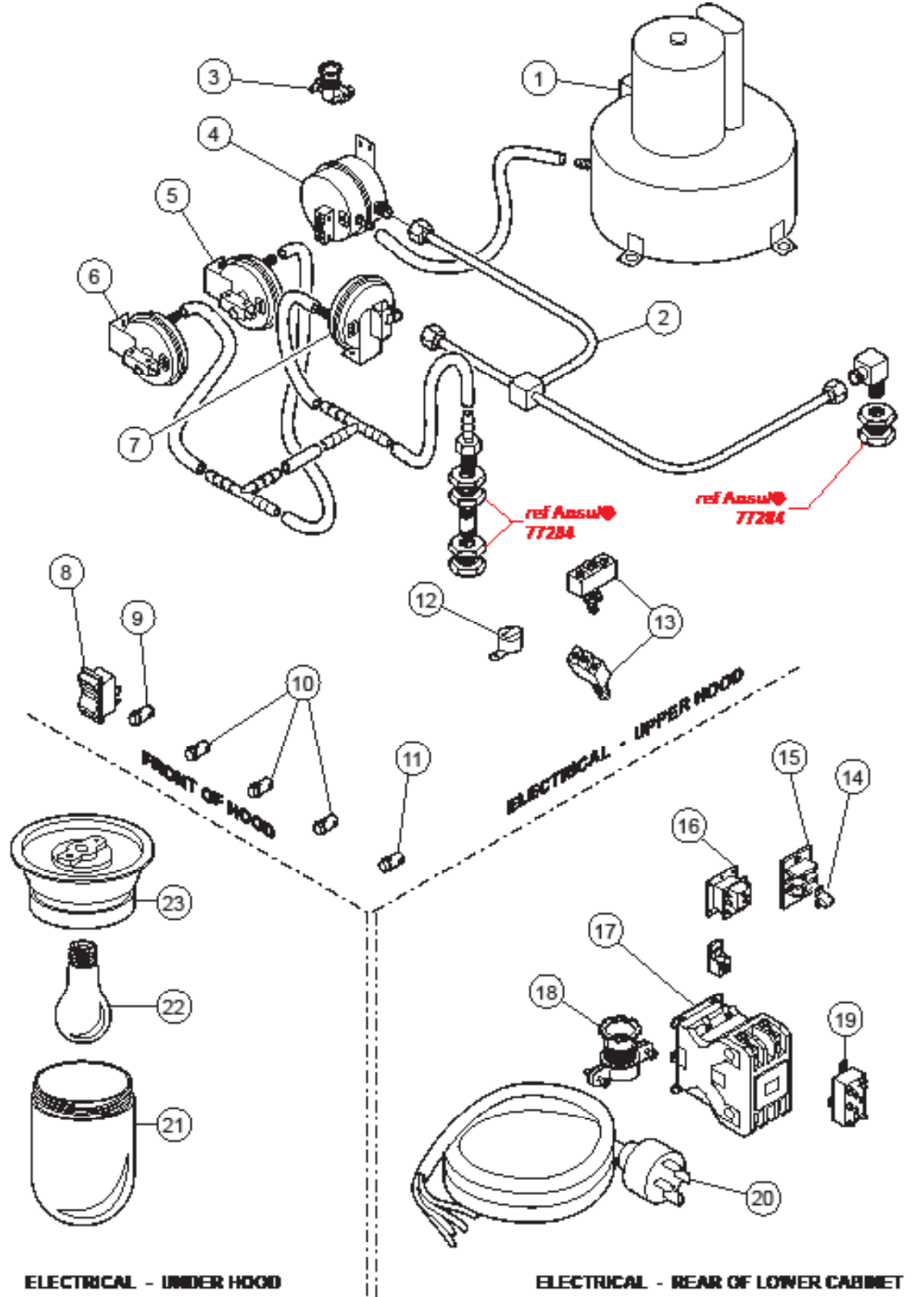

WV4H Hood Electrical & Vacuum Components

IL2176a

M504 p/n 2M-303903 Owners Manual WV-4H Ventless Hopplate Cooktop

EXPLODED VIEW & PARTS LIST

HOOD ELECTRICAL & VACUUM COMPONENTS

Model: WV4H Hood Electrical & Vacuum Components		
Fig No.	Part No	Description
1	2U-302584	BLOWER ASSY UNIVERSAL
2	N1-307594	TUBING ASSY VACUUM UNIV
3	2K-37748X	FTG CONDUIT STRAIGHT 3/8
4	2E-Z24058	SWITCH VACUUM #4
5	2E-Z24055	SWITCH VACUUM #1
6	2E-Z24057	SWITCH VACUUM #3
7	2E-Z24056	SWITCH VACUUM #2
8	2E-70395	SWITCH ROCKER 240V 20A
9	2J-35697	PILOT LT GREEN 250V 1/3W
10	2J-30516	LIGHT SIGNAL AMBER
11	2J-31157	LIGHT SIGNAL RED
12	2J-44834	BUZZER 220V ROHS
13	2E-300407	SWITCH MANUAL ADVANCE
14	2E-34005	JUMPER FLAME SENSOR TERM
15	2E-33068	TERM BLOCK FLAME SENSOR
16	2E-43880	RELAY 208/240 DPDT
17	2E-302789	CONTACTOR 50A 3 PHASE
18	2K-304420	STRAIN RELIEF 1 1/4NPT
19	2E-44514	RELAY 208-240V COIL
20	M3-303130	CORD SET 60AMP 3 PHASE
21	2Q-305099	GLASS GLOBE VCS HOOD
22	2S-305100	LIGHT BULB / 100W -230V FROSTED
23	2E-305098	LIGHT HOUSING VCS HOOD
NI	2T-303892	THERMAL PROTECTOR

EXPLODED VIEW & PARTS LIST

COOKTOP COMPONENTS

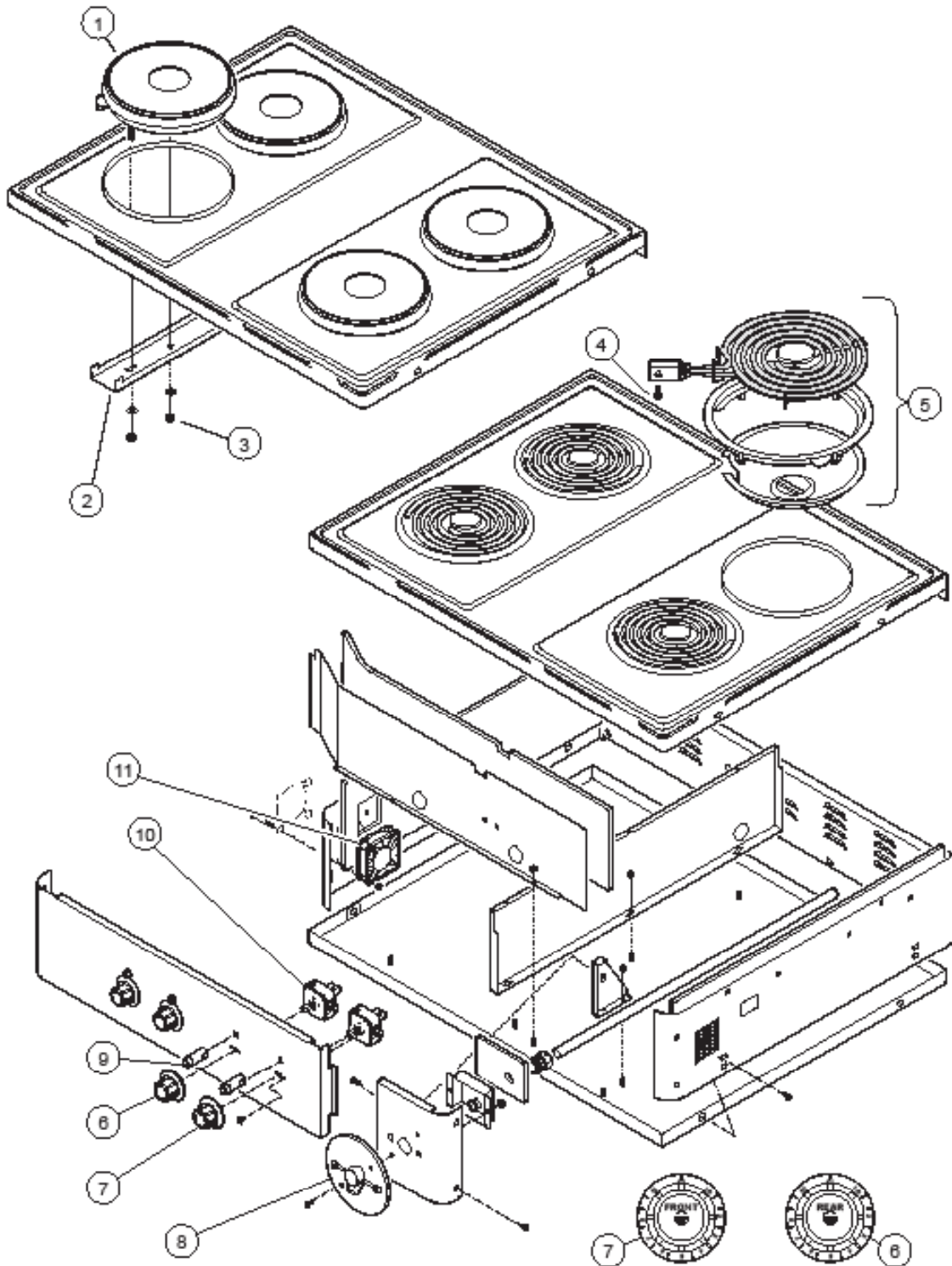

WV4H Cooktop Components

L2175a

M504 p/n 2M-303903 Owners Manual WV-4H Ventless Hopplate Cooktop

EXPLODED VIEW & PARTS LIST

COOKTOP COMPONENTS

Model: WV4H Cooktop Components		
Fig No.	Part No	Description
1	WS-503973	ELMENT HOTPLATE, UPGRADE-FUSED WIRE
2	DD-501451	BRKT SOLID ELEM, HOLD DOWN
3	2C-31053	NUT 8-32 KEPS MS NICKEL
4	2C-33977	SCREW, 8-32X3/8-PHBNHD
5	WS-50293	ELMNT ASSY KIT, 240V@2600W
6	2R-30584	KNOB, HOTPLATE REAR
7	2R-30583	KNOB, HOTPLATE FRONT
8	2O-308131	REMOTE PULL STATION RED
9	2J-30516	LIGHT SIGNAL AMBER
10	2E-30562	SWITCH INFINITE 240V
11	2U-303655	FAN COOLING KIT

EXPLODED VIEW & PARTS LIST

DRAWER WARMER COMPONENTS

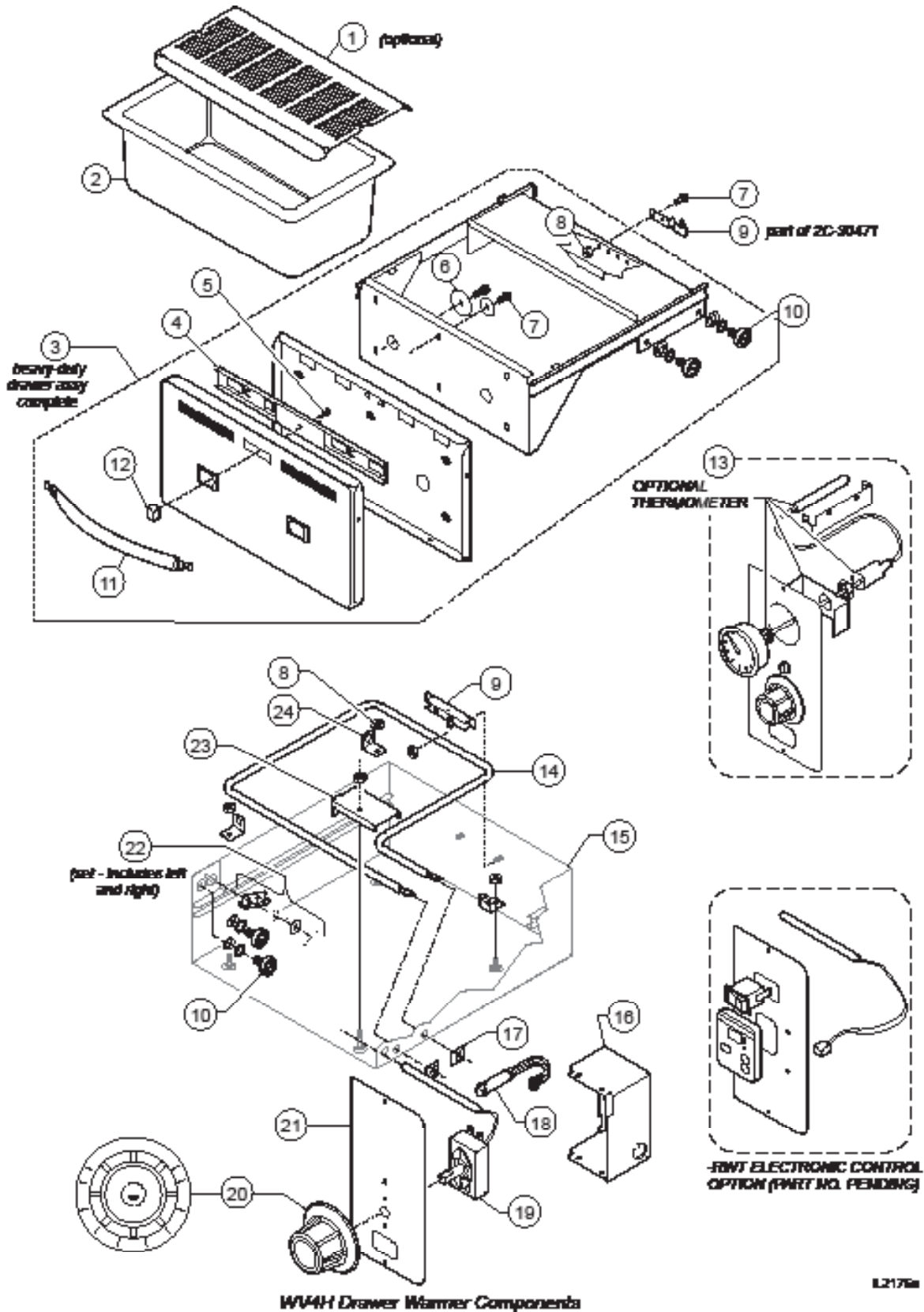

M504 p/n 2M-303903 Owners Manual WV-4H Ventless Hotplate Cooktop

EXPLODED VIEW & PARTS LIST

DRAWER WARMER COMPONENTS

Model: WV4H Drawer Warmer Components			
Fig No.	Part No	Description	Application
1	WS-20624	RACK HUMITROL RWS	OPTIONAL
2	C8-46840	PAN INSERT DRAWER RWHD	
3	WS-67096	DRAWER ASSY KIT	
4	C8-49251	SLIDE VENT ASSY RWN	
5	2C-35530	SCREW, 8-32X3/8PH,RD	
6	2C-35565	WASHER 2 1/16 DRWR BACK	
7	2C-35487	SCREW 8-32X5/16 PH TR HD	
8	2C-35455	NUT 8-32 HEX MS SS	
9	2C-30471	DRAWER STRIKER AND CATCH	
10	2P-30483	BRNG RLLR TRK-R116	
11	C8-32112	HANDLE RW DRAWER SRW	
12	WS-51796	KNOB SQUARE ROLL WARMER	
13	2T-44475	THERMOMETER RW 2IN DIAL	
14	2N-30482UL	ELEM 240V 450W	208/240V
	2N-30519UL	ELEM 120V 450W, ROLL WARMER	120V
15	C8-307637	CAVITY ASSY RW-HD	
16	C8-307569	BOX, OUTLET	
17	2C-43271	CLIP RETAINER PILOT LIGHT	
18	2J-35687	LG SIGNAL, GLODOT	
19	WS-58936	THERMO CTL KIT RW W/O AUX	
20	2R-30372	KNOB CONTROL ASSY, WARMER	
21	C8-Z12392	CONTROL PANEL	UPPER
	C8-33565	PANEL CONTROL LOWER RWS	LOWER
22	WS-65923	REPR KIT-DWR STOP W/SPRING	
23	C8-35683	SHIELD BULB RWS	
24	C8-35677	ANGLE SUPPORT ELEM RWS	

WIRING DIAGRAM

HOOD SECTION

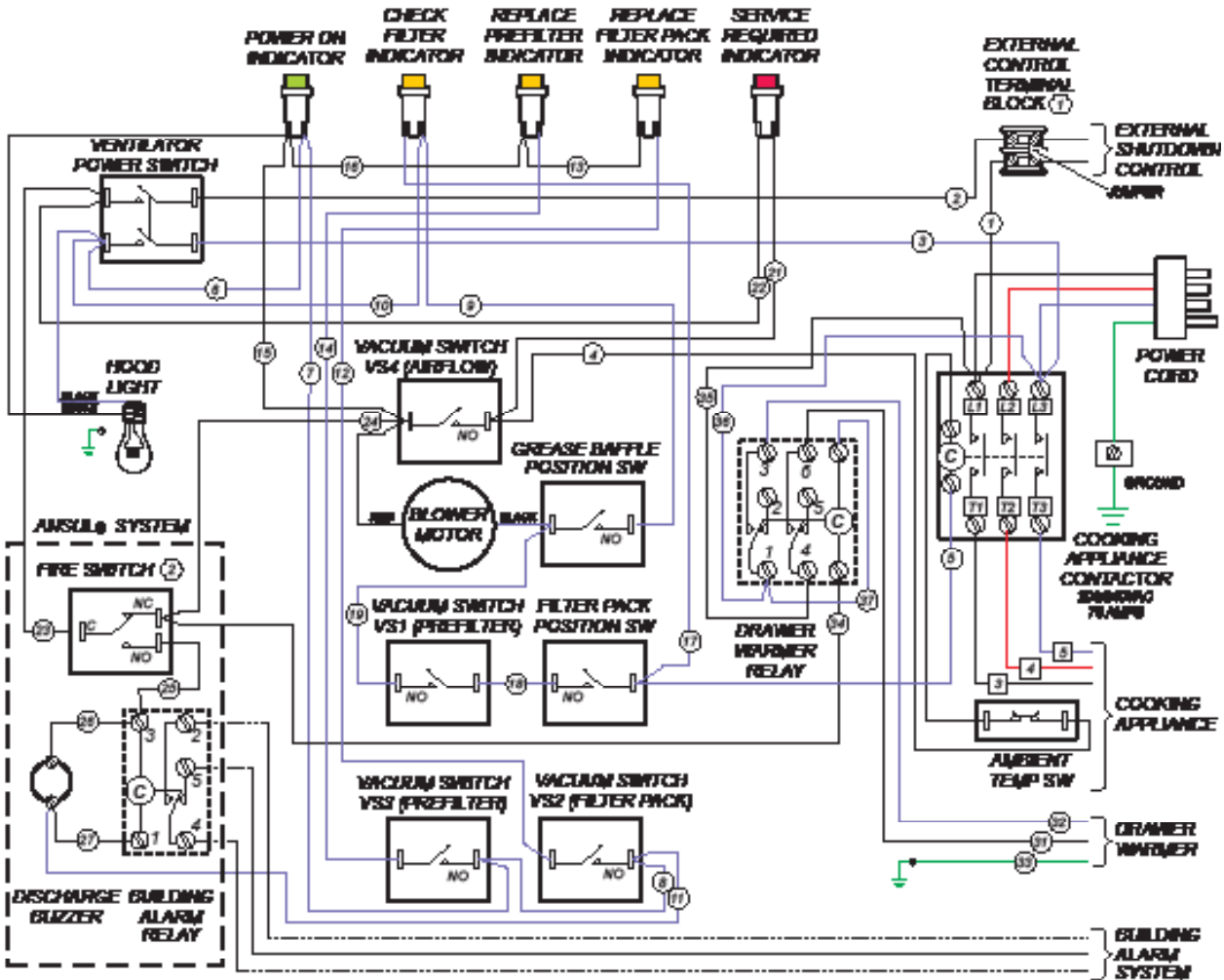

NOTES

1. REMOVE JUMPER WHEN USING EXTERNAL CONTROL.
IMPORTANT:
DO NOT CONNECT ANY POWER TO EXTERNAL CONTROL TERMINAL BLOCK
2. FIRE SWITCH SHOWN WITH ANSUL SYSTEM CHARGED AND COOKED

MODEL	VOLTS 60Hz	3 ϕ AMPS			1 ϕ AMPS	WATTS
		L1	L2	L3		
WV-4F	208V	16	15	26	30	6,300
	240V	18	17	30	35	8,300
WV4HRW, WV4HRWT	208V	19	15	30	34	7,000
	240V	27	22	43	48	11,600
WV4HS	208V	20	19	34	38	8,100
	240V	23	22	39	45	10,700
WV4HSRW, WV4HSRWT	208V	19	15	30	34	7,000
	240V	22	17	34	38	9,200

Drawn by: 302802 Issue: J

WIRING DIAGRAM

HOTPLATE COOKTOP SECTION

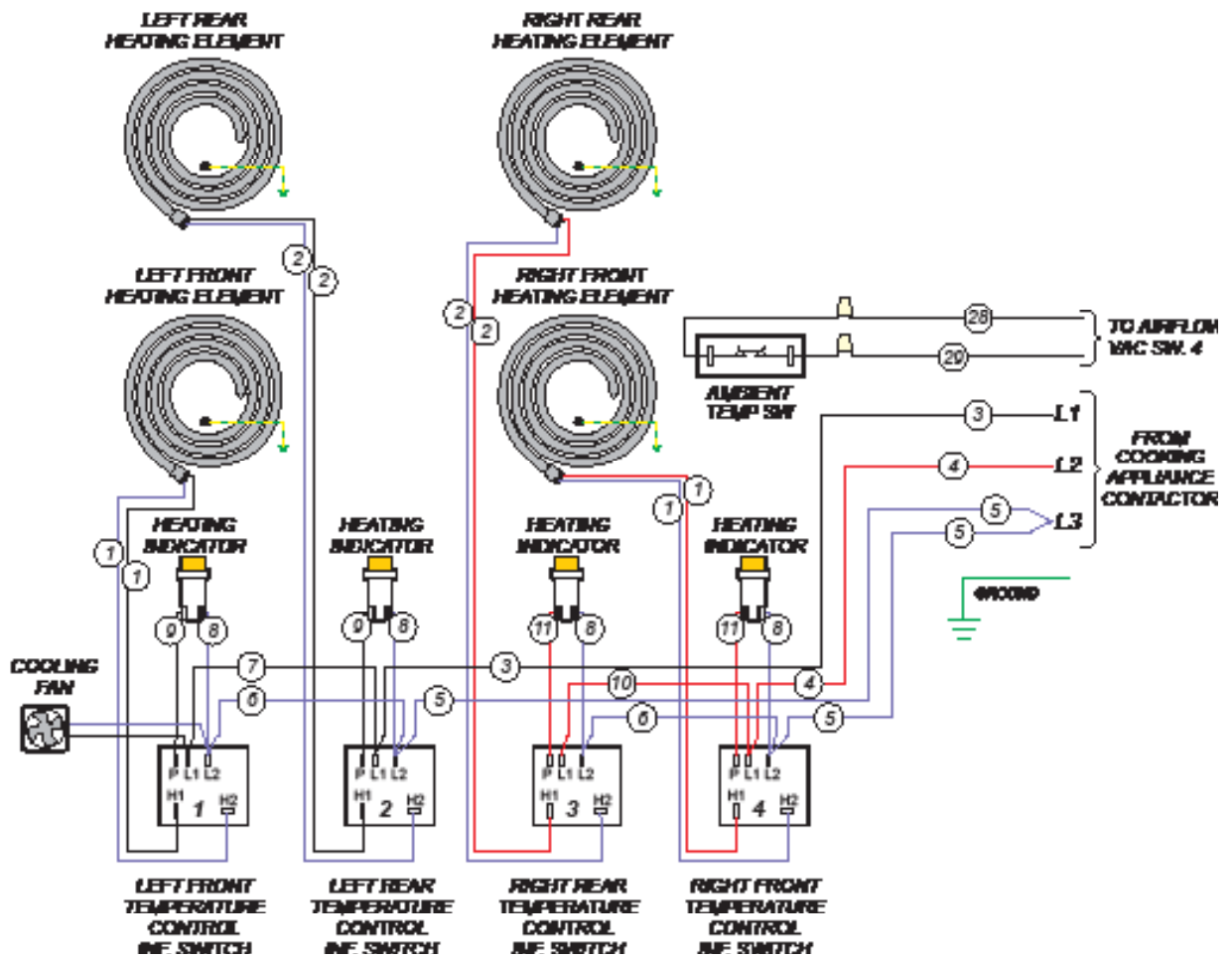

M504 p/n 2M-303903 Owners Manual WV-4H Ventless Hotplate Cooktop

WIRING DIAGRAM

DRAWER WARMER SECTION (RW-STYLE)

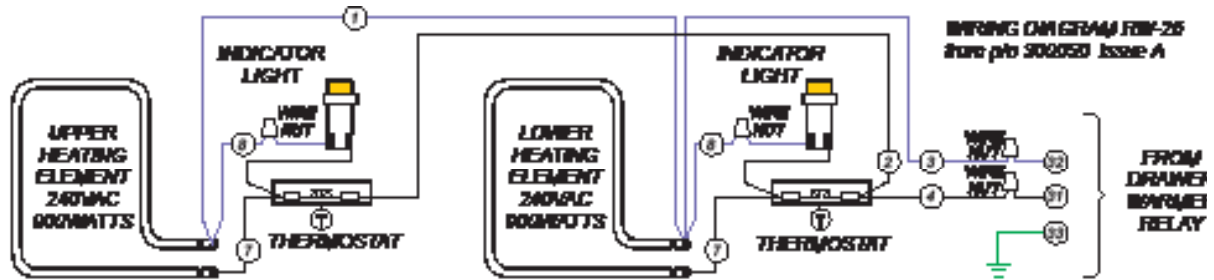

[

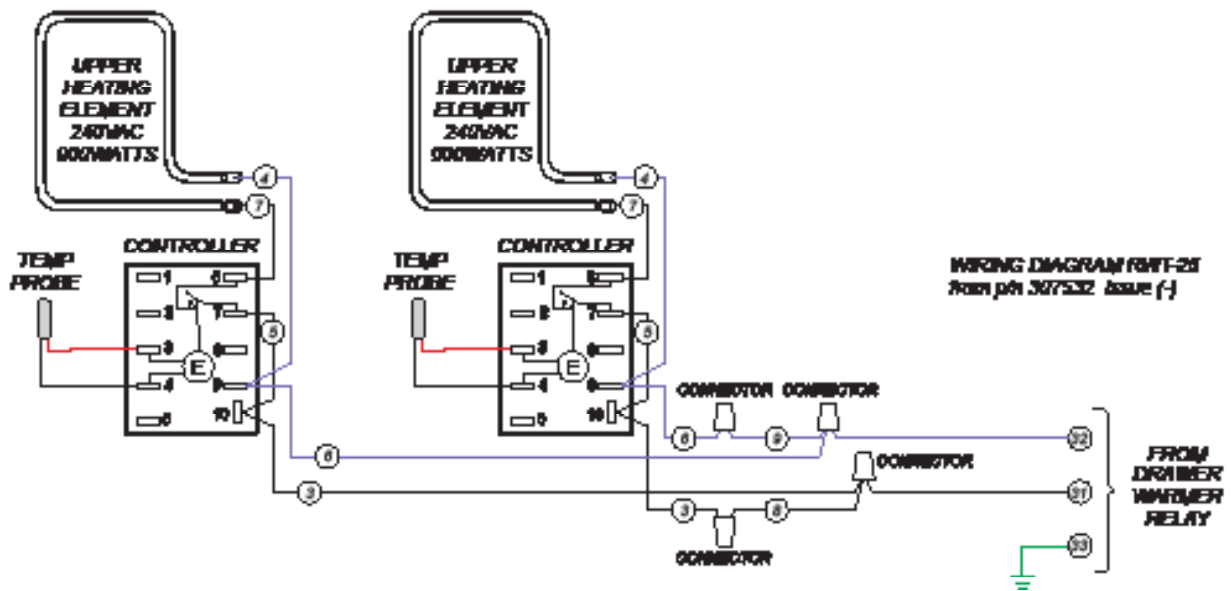

NOTES

NOTES

PARTS & SERVICE

DESCRIPTION

SERVICE PART NO.

IMPORTANT: Use only factory authorized service parts and replacement filters.

PRE-FILTER	2I-302579
PRE-FILTER CAGE	WS-22683
FILTER PACK (HEPA + CHARCOAL)	M3-302775
GREASE BAFFLE	2I-302580
REAR LEG ASSEMBLY	WS-22649
GREASE CUP	DD-302708
DRIP TRAY, 8" (Spiral Hotplate)	I7-30292
SCRAPER, CLEANING(Ceramic Hotplate)	2R-302040
CLEANING CREME, CERAMIC HOTPLATE	2L-301124
DRAWER PAN, REPLACEMENT RACK, HUMITROL	2D-31279 WS-20624

For factory authorized service, or to order factory authorized replacement parts, contact your Wells authorized service agency, or call:

Wells Manufacturing
10 Sunnen Dr.,
St. Louis MO 63143 USA

Service Dept.
phone: (800) 264-7827

Service Parts Department can supply you with the name and telephone number of the **WELLS AUTHORIZED SERVICE AGENCY** nearest you.

WELLS BULLETIN (ANSUL® PARTS LIST)

NOTE: Ansul® Manual 418087-05 is intended for use by authorized Ansul® service personnel only. Ansul® Manual 418087-05 must be obtained through your authorized Ansul® distributor.

CUSTOMER SERVICE DATA

please have this information available if calling for service

RESTAURANT _____ LOCATION _____

INSTALLATION DATE _____ TECHNICIAN _____

SERVICE COMPANY _____

ADDRESS _____ STATE _____ ZIP _____

TELEPHONE NUMBER (____) _____ - _____

EQUIPMENT MODEL NO. _____

EQUIPMENT SERIAL NO. _____

VOLTAGE: (check one) 208 240



Wells proudly supports CFESA
Commercial Food Equipment Service Association

SERVICE TRAINING - QUALITY SERVICE



CUSTOMER SATISFACTION



WELLS MANUFACTURING
265 Hobson Street, Smithville, Tennessee 37166
telephone: 800-264-7827
www.wells-mfg.com