

**WELLS MANUFACTURING**

265 Hobson Street, Smithville, Tennessee 37166

telephone: 314-678-6314

fax: 314-781-2714

www.wells-mfg.com**SUPPLEMENTAL
OWNER'S MANUAL****VENTILATOR HOOD
SECTION
FRYER MODELS****WVPE30F
WVAE55F
WVAE55FC****Includes INSTALLATION
USE & CARE EXPLODED
VIEW PARTS LIST
WIRING DIAGRAM****IMPORTANT: DO NOT DISCARD THIS MANUAL**

This manual is considered to be part of the appliance and is to be given to the OWNER or MANAGER of the restaurant, or to the person responsible for TRAINING OPERATORS of this appliance. Additional manuals are available from your WELLS DEALER.

THIS MANUAL MUST BE READ AND UNDERSTOOD BY ALL PERSONS USING OR INSTALLING THIS APPLIANCE. Contact your WELLS DEALER if you have any questions concerning installation, operation or maintenance of this equipment.

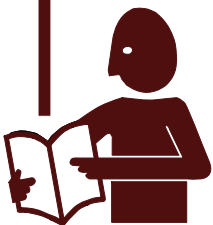

LIMITED EQUIPMENT WARRANTY

Wells Manufacturing warranties new products to be free from defects in material and/or workmanship for a period of one [1] year from the date of original installation, except as noted below. Defects that occur as a result of normal use, within the time period and limitations defined in this warranty, will at Wells' discretion have the parts replaced or repaired by Wells or a Wells-authorized service agency.

THIS WARRANTY IS SUBJECT TO ALL LISTED CONDITIONS.

Repairs performed under this warranty are to be performed by a Wells-authorized service agency. Wells will not be responsible for charges incurred or service performed by non-authorized repair agencies.

In all cases, the nearest Wells-authorized service agency must be used.

Wells will be responsible for normal labor charges incurred in the repair or replacement of a warrantied product within 50 miles (80.5 km) of an authorized service agency. Time and expense charges for anything beyond that distance will be the responsibility of the owner. All labor will need to be performed during regular service hours. Any overtime premium will be charged to the owner. For all shipments outside the U.S.A. and Canada, please see the International Warranty for specific details.

It is the responsibility of the owner to inspect and report any shipping damage claims, hidden or otherwise, promptly following delivery.

No mileage or travel charges will be honored on any equipment that is deemed portable. In general, equipment with a cord and plug weighing less than 50 lb. (22.7 kg) is considered portable and should be taken or shipped to the closest authorized service agency, transportation prepaid.

CONTACT

Should you require any assistance regarding the operation or maintenance of any Wells equipment; write, phone, fax or email our service department. In all correspondence mention the model number and the serial number of your unit, as well as the voltage or type of gas you are using.

Business hours are 8:00 a.m. to 4:30 p.m. Central Standard Time
 Telephone 314.678.6314
 Fax 314.781.2714
 Email customerservice@star-mfg.com
 www.wells-mfg.com

WARRANTY EXCLUSIONS

THE FOLLOWING WILL NOT BE COVERED UNDER WARRANTY.

- Any product which has not been installed, cleaned, maintained, or used in accordance with the directions published in the appropriate installation sheet and/or owner's manual as well as national and local codes, including incorrect gas or electrical connection. Wells is not liable for any unit which has been mishandled, abused, misapplied, subjected to chlorides, harsh chemicals, or caustic cleaners, damaged from exposure to hard water, modified by unauthorized personnel, damaged by flood, fire, or other acts of nature [or God], or which have an altered or missing serial number.
- Installation, labor, and job checkouts, calibration of heat controls, air and gas burner/bypass/pilot adjustments, gas or electrical system checks, voltage and phase conversions, cleaning of equipment, or seasoning of griddle surface.
- Replacement of fuses or resetting of circuit breakers, safety controls, or reset buttons.
- Replacement of broken or damaged glass components, quartz heating elements, and light bulbs.
- Labor charges for all removable parts in gas charbroilers and hotplates, including but not limited to burners, grates, and radiants.
- Any labor charges incurred by delays, waiting time, or operating restrictions that hinder a service technician's ability to perform service.
- Parts that fail or are damaged due to normal wear or labor for replacement of Items that can easily be replaced during a daily cleaning routine. such as but not limited to silicone belts, PTFE non-stick sheets, knobs, control labels, bulbs, fuses, quartz heating elements, baskets, racks, and grease drawers.
- Components that should be replaced when damaged or worn, but have been field-repaired instead [eg. field-welded fry pots].
- Any loss of business or profits.

ADDITIONAL WARRANTIES

Specialty/chain specific versions may also have additional and/or extended warranties.

| PRODUCTS | PARTS | LABOR |
|---|---------|--------|
| universal ventless hoods | 2 years | 1 year |
| canopy hoods | 2 years | 1 year |
| "Cook'n Hold" equipment [HW10, HWSMP, LLSC7, LLSC7WA, LLSC11, and LLSC11WA] | 2 years | 1 year |
| cast iron grates, burners, and burner shields | 1 year | |
| original Wells parts sold to repair Wells equipment | 90 days | |
| Service First | 1 year | |

TABLE OF CONTENTS

| | |
|-----------------------------------|----|
| WARRANTY | 1 |
| SPECIFICATIONS | 2 |
| FEATURES & OPERATING CONTROLS | 2 |
| PRECAUTIONS & GENERAL INFORMATION | 4 |
| AGENCY LISTING INFORMATION | 5 |
| INSTALLATION | 5 |
| ANSUL® INSTALLATION & SETUP | 8 |
| OPERATION | 11 |
| CLEANING INSTRUCTIONS | 12 |
| MAINTENANCE INSTRUCTIONS | 14 |
| TROUBLESHOOTING SUGGESTIONS | 15 |

INTRODUCTION

Thank You for purchasing this Wells Manufacturing appliance.

Proper installation, professional operation and consistent maintenance of this appliance will ensure that it gives you the very best performance and a long, economical service life.

This supplemental manual contains information and instructions pertinent to the hood section of this ventless appliance, and to its use and care.

For information regarding the fryer section, please refer to the associated fryer owners manual.

DIMENSIONS

| MODEL | WIDE | DEEP | HIGH |
|-------|--|--------------------|--------------------|
| ALL | 15.8" (402 mm) | 43.7" (1110 mm) | 76.4" (1941 mm) |
| | 20" (508 mm) including manual pull station | | |

ELECTRICAL SPECIFICATIONS

| MODEL | VOLTS | WATTS | AMPS |
|----------|--------|--------|-------------------|
| WVPE30F | 208 1ø | 9,000 | 43.3 |
| | 240 1ø | 9,000 | 37.5 |
| | 208 3ø | 9,000 | 25.0 (L1, L2, L3) |
| | 240 3ø | 9,000 | 22.0 (L1, L2, L3) |
| WVAE55F | 208 3ø | 17,000 | 47.8 (L1, L2, L3) |
| | 240 3ø | 17,000 | 42.0 (L1, L2, L3) |
| WVAE55FC | 208 1ø | 11,340 | 56 |
| | 240 1ø | 11,340 | 48 |
| | 208 3ø | 17,000 | 47.8 (L1, L2, L3) |
| | 240 3ø | 17,000 | 42.0 (L1, L2, L3) |

FEATURES & OPERATING CONTROLS

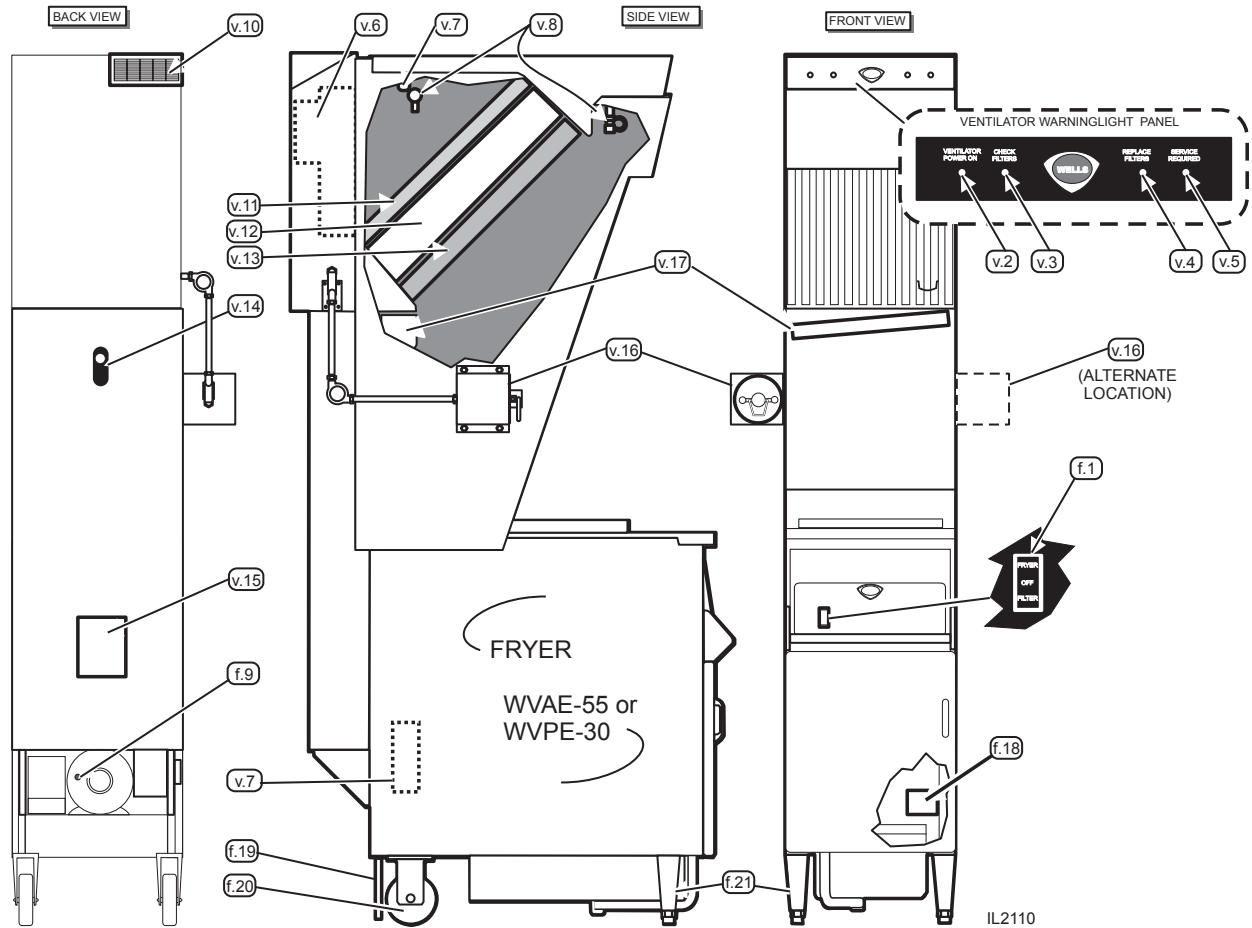

IL2110

NOTE: Items beginning with "f. ..." are part of the FRYER
 Items beginning with "v. ..." are part of the VENTILATOR

FEATURES & OPERATING CONTROLS (continued)

| ITEM | DESCRIPTION | FUNCTION |
|---|---|--|
| f.1 | POWER SWITCH <i>(FILTER-OFF-FRYER)</i> | <i>FRYER</i> position energizes VENTILATOR POWER LIGHT and BLOWER. If, within 10 seconds, there is sufficient airflow for proper operation, POWER LIGHT will remain ON and fryer will operate. |
| v.2 | VENTILATOR POWER LIGHT (green) | Glow when FRYER POWER SWITCH is pressed to <i>FRYER</i> and adequate airflow has been proven. |
| v.3 | CHECK FILTERS LIGHT (amber) | Glow when GREASE BAFFLE and/or HEPA FILTER are not properly installed. When this light is lit, fryer is disabled. |
| v.4 | REPLACE FILTERS LIGHT (amber) | Glow if either CHARCOAL FILTER or HEPA FILTER are due for replacement. Fryer will continue to operate, but filters must be changed in a timely manner before they clog and disable the fryer. |
| v.5 | SERVICE REQUIRED LIGHT (red) | Glow when there is insufficient airflow for proper operation (either CHARCOAL FILTER or HEPA FILTER, or both, plugged). When this light is lit, fryer is disabled. |
| v.6 | VENTILATOR BLOWER | Provides ventilation airflow. |
| v.7 | FUSIBLE LINK LOCATION | FUSIBLE LINKS provide fire protection by melting at a pre-set temperature and activating the fire suppression system. |
| v.8 | FIRE SUPPRESSION NOZZLE(S) | Disperse the fire suppression media. |
| f.9 | FILTER PUMP MOTOR OVERLOAD RESET | Provides over-temperature protection for the FILTER PUMP MOTOR. Reset manually by pressing the red button. |
| v.10 | VENTILATOR EXHAUST COLLAR | Ventilator discharge. DO NOT BLOCK. Contains fire damper with pre-installed 285°F (141°C) fusible link. |
| v.11 | CHARCOAL FILTER | See page 10. |
| v.12 | HEPA AIR FILTER | |
| v.13 | GREASE BAFFLE | |
| v.14 | ANSUL® SYSTEM STATUS INDICATOR | Indicates status of Ansul® fire suppression system (i.e. <i>COCKED</i> or <i>FIRED</i>). |
| v.15 | ACCESS TO AUTOLIFT MOTOR | On fryers with automatic basket lifting device (WVAE-series) allows servicing of lift mechanism. |
| v.16 | MANUAL PULL STATION | Allows manual discharge of fire suppression system. Shown on left side, may also be mounted on right side. IMPORTANT: PULL STATION must be field installed by an ANSUL® technician. |
| v.17 | GREASE CUP | Catches drippings from GREASE BAFFLE. |
| f.18 | DRIP PAN | Catches any liquid draining from top of fryer section. |
| f.19 | STABILIZER | Prevents unit from tipping backwards. |
| f.20 | RIGID (REAR) CASTERS | Allows unit to be easily positioned by slightly lifting front of unit. |
| IMPORTANT | | |
| If a remote pull station is installed, both rear casters must be replaced with fixed legs in order to deter movement of unit. MOVING AN APPLIANCE EQUIPPED WITH A REMOTE PULL STATION WILL DISCHARGE THE FIRE SUPPRESSION SYSTEM. | | |
| f.21 | FIXED (FRONT) LEGS | Allows the unit to be leveled. |

PRECAUTIONS AND GENERAL INFORMATION



WARNING: SHOCK HAZARD

All servicing requiring access to non-insulated electrical components must be performed by a factory authorized technician. DO NOT open any access panel which requires the use of tools. Failure to follow this warning can result in severe electrical shock.



CAUTION: RISK OF DAMAGE

DO NOT connect or energize this appliance until all installation instructions are read and followed. Damage to the appliance will result if these instructions are not followed.



CAUTION: HOT SURFACE

Exposed surfaces can be hot to the touch and may cause burns.

IMPORTANT:

The fryer is disabled when the filters are plugged to the point of insufficient airflow for proper operation. Also, the fryer is disabled if either the HEPA filter or grease baffle is removed. It is the responsibility of the store management to maintain sufficient spares of HEPA air filters to avoid prolonged shutdown of the fryer when this filter is expended. Charcoal and HEPA air filters cannot be cleaned. Wells Manufacturing assumes no liability for loss of business due to filter related shutdown.

This ventilator hood is part of an engineered system and is intended for use in commercial establishments only.

This ventilator and attendant fryer are intended to prepare food for human consumption. No other use is recommended or authorized by the manufacturer or its agents.

Operators of this appliance must be familiar with the appliance use, limitations and associated restrictions. Operating instructions must be read and understood by all persons using or installing this appliance.

This ventilator hood system is designed to reduce odor emissions, but will not completely eliminate all cooking odors. Air exchange rates at the installation site must comply with the requirements of the local jurisdictional authority. To ensure that odors do not accumulate, recommended minimum air exchange is 400 cfm into *and out of* the site.

Cleanliness of this appliance is essential to good sanitation. Read and follow all included cleaning instructions and schedules to ensure the safety of the food product.

Disconnect this appliance from electrical power before performing any maintenance or servicing.

This appliance is not jet stream approved. Do not direct water jet or steam jet at this appliance, or at any control panel or wiring. Do not splash or pour water on, in or over any controls, control panel or wiring. Do not wash floor around this appliance with water or steam jet. Do not attempt to wash charcoal or HEPA air filters. Water will cause their immediate failure and disable the fryer.

Exposed surfaces of this appliance can be hot to the touch and may cause burns.

Cooking oil will be very hot when in use. Contact will cause severe injury. Wear appropriate heat protective apron and gloves when using this fryer.

Do not operate this appliance if the control panel is damaged. Do not operate solid state versions of this appliance if the keypad section of the control panel is torn or broken. Call your Authorized Wells Service Agent for service.

Avoid storing flammable or combustible materials in, on or near the appliance.

The technical content of this manual, including any wiring diagrams, schematics, parts breakdown illustrations and/or adjustment procedures, is intended for use by qualified technical personnel.

Any procedure which requires the use of tools must be performed by a qualified technician.

This manual is considered to be a permanent part of the appliance. This manual and all supplied instructions, diagrams, schematics, parts breakdown illustrations, notices and labels must remain with the appliance if it is sold or moved to another location.

This appliance is made in the USA. Unless otherwise noted, this appliance has American sizes on all hardware.

AGENCY LISTING INFORMATION

This appliance conforms to NSF Standard 4 for sanitation only if installed in accordance with the supplied *Installation Instructions* and maintained according to the instructions in this manual.

This appliance is  and  Listed under UL File E146882.



STD 4



E146882



E146882

INSTALLATION

UNPACKING & INSPECTION

Carefully remove the appliance from the carton. Remove all protective plastic film, packing materials and accessories from the appliance before connecting electrical power or otherwise performing any installation procedure.

Carefully read all instructions in this manual before starting any installation.

Read and understand all labels and diagrams attached to the Fryer and to the ventilator.

Carefully account for all components and accessories before discarding packing materials.

COMPONENTS

- 1 ea. Grease baffle
- 1 ea. HEPA air filter
- 1 ea. Charcoal filter
- 1 ea. Grease cup

- 1 ea. Fire suppression agent tank
- 1 ea. Fire suppression agent (Ansul[®] Low pH) 1.5 gal.
- 1 ea. Fire suppression system charging cartridge
- 1 ea. Manual pull station kit
(includes mounting hardware - must be installed by an authorized ANSUL[®] distributor only)

- (as req'd) Components and accessories specific to the fryer. Store these components in a convenient place for later use

- .Optional Ansul[®] inspection window and equipment standards.

NOTE: DO NOT discard the carton or other packing materials until you have inspected the appliance for hidden damage and tested it for proper operation. Refer to *SHIPPING DAMAGE CLAIM PROCEDURE* on the inside front cover of this manual.



WARNING:
RISK OF INJURY

Installation procedures must be performed by a qualified technician with full knowledge of all applicable electrical codes. Failure can result in personal injury and property damage.

IMPORTANT:

Fire suppression system must be charged and certified by an authorized Ansul[®] distributor. Fryer will not operate until the fire suppression system has been charged.

INSTALLATION (continued)



WARNING: **SHOCK HAZARD**

All servicing requiring access to non-insulated electrical components must be performed by a factory authorized technician. DO NOT open any access panel which requires the use of tools. Failure to follow this warning can result in severe electrical shock.



CAUTION: **RISK OF DAMAGE**

DO NOT connect or energize this appliance until all installation instructions are read and followed. Damage to the appliance will result if these instructions are not followed.

IMPORTANT:
If a remote pull station is to be used, replace the rear casters with fixed legs.

SERVICE TECHNICIAN INSTALLATION NOTES

Installation and start up must be performed by an Authorized Installation Company.

Installer must complete the WARRANTY REGISTRATION / FRYER CHECKOUT form, and record fryer installation particulars on the CUSTOMER SERVICE DATA form in this manual.

IT IS THE RESPONSIBILITY OF THE INSTALLER TO verify that this FRYER and VENTILATOR installation is in compliance with the specifications listed in this manual, with local code requirements, and in accordance with the STANDARD FOR VENTILATION CONTROL AND FIRE PROTECTION OF COMMERCIAL COOKING OPERATIONS as detailed in N.F.P.A 96 (current edition).

Certain codes require fryers to be restrained with a TETHER or other RESTRAINT DEVICE. It is the RESPONSIBILITY OF THE INSTALLER to check with the AUTHORITY HAVING JURISDICTION, in order to ascertain the applicability of this requirement to THIS SPECIFIC FRYER INSTALLATION. Any restraint device must allow access to the back and sides of the unit to provide for servicing and maintenance, and must not interfere with the operation of the fire suppression system.

SETUP

Setup the appliance only on a firm, level, non-combustible surface. Verify local codes for requirements. Concrete, tile, terrazzo or metal surfaces are recommended. Metal over combustible material may not meet code for non-combustible surfaces.

Verify vertical clearances. Ventilator fryers require a minimum of 96" (floor to overhead) to allow or adequate air circulation.

Verify that the VENTILATOR HOOD ASSEMBLY is properly and securely assembled to the FRYER before beginning the installation procedure. Ventilator may have become dislodged during shipping or unpacking.

Verify that the unit sits firmly ON ALL FOUR LEGS / CASTERS. With a spirit level, check that the appliance is level front-to-back and side-to-side. With the adjustable legs, adjust as required to level the appliance. In order to prevent tipping, legs must be adjusted such that all four legs / casters are in firm contact with the floor.

Adjust rear stabilizer bars (see item f.19, page 2) to within 1/4" (6 mm) of floor to allow unit to be moved without tipping backwards.

Refer to the *Installation Instruction Sheet* for required clearances. Maintain required clearances between the appliance and adjacent combustible surfaces.

Inspection Window

For units equipped with the Ansul® component inspection window, install the equipment stand-off bracket

INSTALLATION (continued)

ELECTRICAL INSTALLATION

Refer to the nameplate on the front of the fryer. Verify ELECTRICAL SERVICE POWER. Voltage and phase must match the nameplate specifications, and available electrical service amperage must meet or exceed the specifications listed on page 1 of this manual.

- Wiring must be no less than 12 ga. solid copper wire, rated for at least 75°C.
- Wire gauge, insulation type and temperature rating, as well as type, size and construction of conduit, must meet or exceed applicable specifications of local codes and of the National Electrical Code.

30 lb. fryers are shipped from the factory wired for 3-phase electrical service. 55 lb. fryers can be shipped as 1-phase or 3-phase. Refer to the proper wiring diagram included with this fryer, and verify that field wiring conforms to this diagram.

55 lb. FRYERS must be ordered as 1-phase or 3-phase. 30 lb. FRYERS are FIELD CONVERTIBLE to 1-phase. If 1-phase operation is required, refer to the 3-phase to 1-phase Instructions included with the FRYER, and verify that both internal wiring and field wiring conform to the included single-phase wiring diagram.



WARNING SHOCK HAZARD

Electrical connections must be made by a licensed electrician.



CAUTION: SHOCK HAZARD

The ground lug of this appliance must be connected to a suitable building ground.

IMPORTANT:
WVAE-55F and WVAE-55FC units **MUST NOT BE CONVERTED TO SINGLE PHASE OPERATION.** Conversion of these units to single phase operation invalidates the UL listing and will void the warranty.

IMPORTANT:
Contact a licensed electrician to install and connect electrical power to the appliance.

IMPORTANT:
Damage due to being connected to the wrong voltage or phase is **NOT** covered by warranty.

INSTALLATION (continued)



DANGER FIRE HAZARD

Fire suppression system must be charged and certified by an authorized Ansul® distributor.

DO NOT attempt to modify or bypass the fire suppression system.

An uncontrolled fire can cause serious injury or death.

NOTE:

If the fire suppression system is discharged, a buzzer will sound continuously. The fryer will remain inoperable until the fire suppression system is serviced, recharged and reset by an authorized Ansul® distributor.

Charging of the Ansul® Fire Suppression system must be in accordance with Ansul® Design, Installation, Recharge and Maintenance Manual, #418087.

NOTE:

If a REMOTE MANUAL PULL STATION is installed, moving the FRYER for servicing may cause the Ansul® system to discharge. In this case, the unit must only be installed with four fixed legs (i.e. remove rear casters and replace with legs). Additional legs may be ordered through an Authorized Wells Service Agency. See page 19.

FIRE SUPPRESSION SYSTEM INSTALLATION

FIRE SUPPRESSION SYSTEM is comprised of a container of Ansul® Low pH liquid fire suppression media, a system pressurization canister and associated plumbing and controls.

Two FUSIBLE LINKS are utilized for automatic actuation, and a MANUAL PULL STATION for manual actuation. Two NOZZLES disperse the fire suppression media.

The hood is supplied with a field installed MANUAL PULL STATION, which must be set-up at the time of the fryer installation by an authorized Ansul® distributor. See below and following page for installation details.

If the fryer is installed such that the supplied manual pull station cannot be installed, a REMOTE MANUAL PULL STATION may be required by local codes. Any such remote manual pull station must be installed by an authorized Ansul® distributor in accordance with the AUTHORITY HAVING JURISDICTION.

When the fire suppression system discharges, fryer heating element(s) and controls are de-energized, and fire suppression media discharged. Fire suppression media will form an emulsion designed to both smother and cool the oil.

The PRIMARY 450°F FUSIBLE LINK is located on the frypot. This link will melt and discharge the fire suppression system should both the TEMPERATURE CONTROL THERMOSTAT and the HIGH LIMIT CONTROL fail. The SECONDARY 280°F FUSIBLE LINK is located in the filter plenum, and will protect against a fire in the plenum. Either link melting will discharge the fire suppression media through both NOZZLES, and cause a buzzer to sound.

The MANUAL PULL STATION and any similar REMOTE MANUAL PULL STATION will activate the fire suppression system when the ring on the pull station is pulled to its full extent.

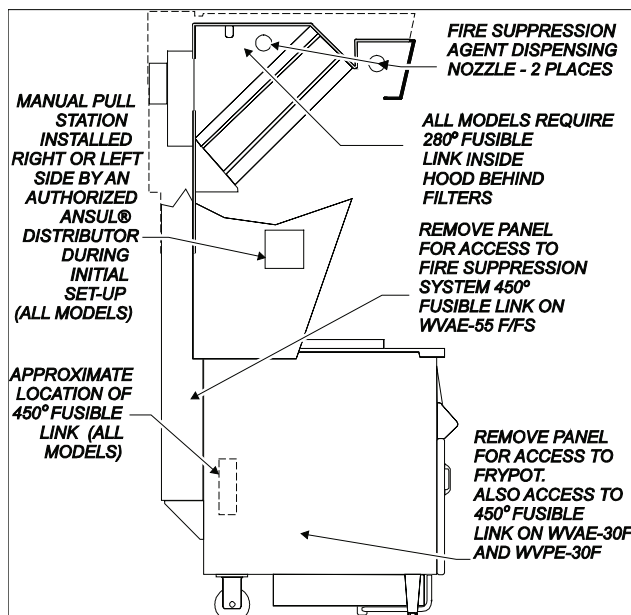

INSTALLATION (continued)

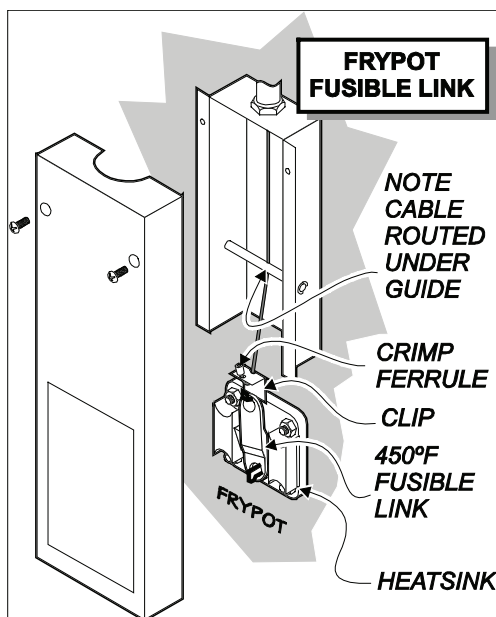
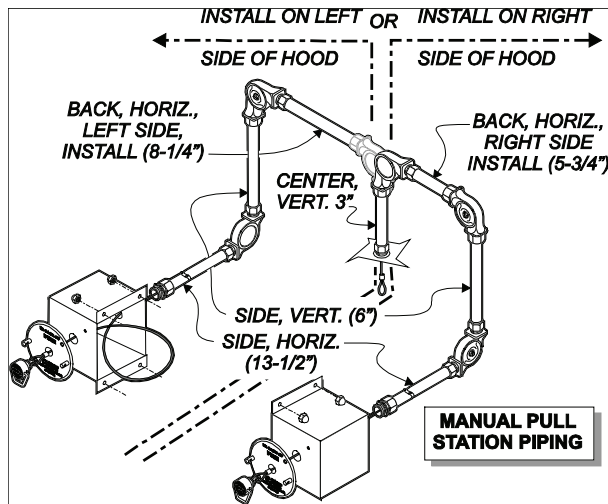
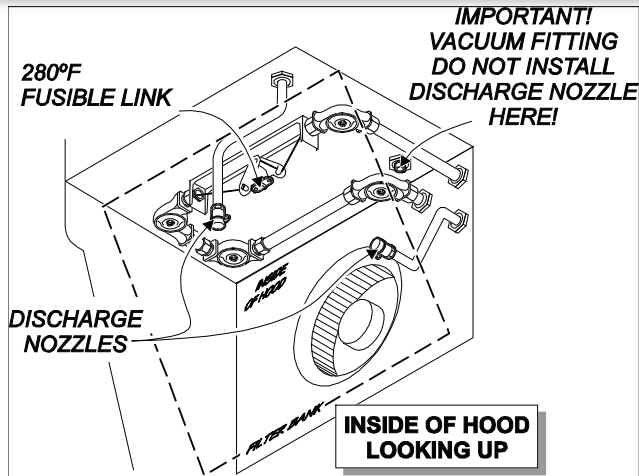

DANGER
BURN HAZARD
HOT OIL SPILL

Any additional remote pull station must not be installed on the front or sides of the fryer forward of the ventilator side panels.

Discharge of the fire extinguishing system into hot oil will cause hot foam to spill over from the frypot.

Serious burns and other injuries can result from contact with hot oil and from slipping in spilled oil.

Exclusive Anti-Fire System

In the unlikely event that both the temperature control thermostat and hi-limit detector fail, and the oil temperature climbs above the safety limit, the fire suppression system will discharge, cooling the oil below the oil's (approximately) 540°F auto-ignition temperature, and preventing a fire from occurring.

INSTALLATION (continued)

NOTE:

The GREASE BAFFLE and HEPA AIR FILTER actuate magnetic reed switches when they are in their proper positions. They must be properly installed or the fryer heater elements will not be energized.

NOTE:

Remove the protective plastic bag from the optional charcoal filter before installing. Installing the filter without removing the plastic bag will block the air flow. This will cause the ventilator to shut down 10 seconds after start-up, and the fryer will not heat.

FILTER INSTALLATION

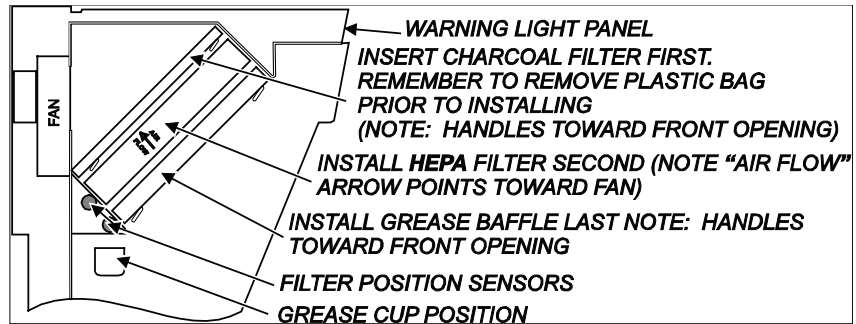

Remove the protective plastic bag from charcoal filter before installing.

Note air flow direction arrow on each filter, and verify that arrow points toward plenum when filter is properly installed.

Install filters by inserting top of each into top filter support inside hood assembly. Pivot bottom of each filter toward rear of hood assembly and drop it into its respective bottom filter support. Seat each filter firmly into the bottom filter support.

Install CHARCOAL FILTER first, followed by HEPA AIR FILTER. Install GREASE BAFFLE last.

GREASE CUP & DRIP PAN INSTALLATION

Install GREASE CUP into brackets below grease baffle.

Note: Failure to install GREASE CUP will allow grease and moisture from GREASE BAFFLE to drop into FRYPOT, creating both a SAFETY HAZARD (hot oil splatter) and a HEALTH HAZARD (contamination of the cooking oil).

Install DRIP PAN into mounting bracket behind fryer door at lower right front of fryer.

Note: Failure to install DRIP PAN will allow grease, moisture and other liquids that accumulate on the fryer top panel to drip onto floor, creating both a SAFETY HAZARD (slip and fall hazard) and a HEALTH HAZARD (substance capable of supporting bacteria).



WARNING
SLIP AND FALL
HAZARD

DO NOT operate fryer unless drip pan is installed. Oil will drip onto floor creating a slipping hazard.



CAUTION
BURN HAZARD

DO NOT operate fryer unless grease cup is installed. Moisture dripping into hot oil will cause hot oil to splatter.

OPERATION

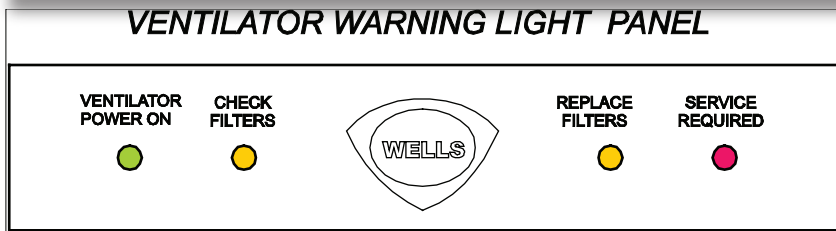

NOTE: Fryer must be operated in accordance with the instructions in the accompanying FRYER OPERATION MANUAL.

During normal operation, VENTILATOR POWER ON light will be the only light illuminated on VENTILATOR WARNING LIGHT PANEL.

If the CHECK FILTERS light illuminates, check both GREASE BAFFLE and the HEPA AIR FILTER for proper installation.

If REPLACE FILTERS light illuminates, replace both HEPA AIR FILTER and CHARCOAL FILTER. Always replace both filters at the same time.

NOTE: REPLACE FILTERS light is a warning that filters are nearing the end of their service life. The fryer will continue to operate for a period of time after REPLACE FILTER LIGHT turns ON to allow continued fryer operation through a peak period. However, filters must be replaced within a short time period or they will clog, disabling the fryer.

If SERVICE REQUIRED light illuminates, filters are restricted to the point of insufficient airflow for proper operation. Fryer is shut down until the underlying clogged filter situation has been corrected. Normally, replacing both HEPA AIR FILTER and CHARCOAL FILTER will remedy the condition. Reset the unit by turning FRYER POWER SWITCH to OFF, then back to FRYER.

A failure of incoming electric power will cause a shut down of the unit. Reset the unit by turning the FRYER POWER SWITCH to OFF, then back to FRYER.



CAUTION:
HOT SURFACE

Exposed surfaces can be hot to the touch and may cause burns.



CAUTION:
SHOCK HAZARD

DO NOT splash or pour water or grease onto control panel or wiring.

IMPORTANT:

The fryer is disabled when REPLACE FILTERS light is illuminated. Note that the fryer cannot operate if the HEPA air filter is removed.

It is the responsibility of the store management to maintain sufficient spares of HEPA air filters to avoid prolonged shutdown of the fryer when this filter is expended.

Charcoal and HEPA air filters cannot be cleaned.

Wells Manufacturing assumes no liability for loss of business due to filter related shutdown.

CLEANING INSTRUCTIONS



CAUTION:
HOT SURFACE

Exposed surfaces can be hot to the touch and may cause burns.



CAUTION:
SHOCK HAZARD

DO NOT splash or pour water or grease onto control panel or wiring.

PRECAUTIONS: Disconnect unit from electric power and allow to cool. Cover frypot to prevent oil contamination.

FREQUENCY: Weekly

TOOLS: Mild detergent, clean non-abrasive towels

NOTE: Ventilator section to be cleaned in conjunction with fryer. Refer to Fryer Operation Manual for fryer cleaning instructions.

1. Disconnect unit from electric power and allow to cool. Cover frypot to prevent oil contamination.
2. Remove GREASE BAFFLE, GREASE CUP and DRIP PAN.
3. Empty GREASE CUP and DRIP PAN into an appropriate grease collection receptacle.
4. Clean GREASE BAFFLE, GREASE CUP and DRIP PAN in a sink or dishwasher using mild detergent and warm water.
5. Dry components with a clean non-abrasive cloth. Reinstall DRIP PAN, GREASE CUP, and GREASE BAFFLE.
6. Wipe exterior of fryer and ventilator with a clean cloth moistened with warm water and mild detergent. Rinse by wiping with a clean cloth moistened with warm water.
7. Uncover the frypot and reconnect unit to electric power.

Procedure is complete

CLEANING INSTRUCTIONS (continued)

PRECAUTIONS: Disconnect unit from electric power and allow to cool
Cover frypot to prevent oil contamination

FREQUENCY: Monthly

TOOLS: Mild detergent, clean non-abrasive towels

NOTE: Ventilator section to be cleaned in conjunction with fryer
Refer to Fryer Operation Manual for fryer cleaning instructions.

1. Disconnect unit from electric power and allow to cool.
Cover frypot to prevent oil contamination.
2. Remove GREASE BAFFLE, HEPA AIR FILTER and CHARCOAL FILTER.
3. Wipe interior of ventilator with a clean cloth moistened with warm water and mild detergent. Rinse by wiping with a clean cloth moistened with warm water. DO NOT clean by spraying.
4. Dry ventilator thoroughly with a clean non-abrasive cloth. Reinstall CHARCOAL FILTER, HEPA AIR FILTER and GREASE BAFFLE..
5. Uncover the frypot and reconnect unit to electric power.

Procedure is complete



CAUTION:
HOT SURFACE

Exposed surfaces can be hot to the touch and may cause burns.



CAUTION:
SHOCK HAZARD

DO NOT splash or pour water or grease onto control panel or wiring.

IMPORTANT:

DO NOT wash HEPA air filter or CHARCOAL filter. Washing these filters will clog them, and cause fryer to be disabled.

IMPORTANT:

DO NOT clean interior of ventilator by spraying. Spraying can contaminate the cooking oil, and may cause internal damage to the blower, operation proofing system and/or fire suppression system. Clean by wiping only.

REQUIRED MAINTENANCE

IMPORTANT:

A signed and dated FRYER HOOD MAINTENANCE LOG must be maintained on the premises, and shall be made available for inspection by the authority having jurisdiction upon request.
See page 15.

USE AND MAINTENANCE SHALL BE IN ACCORDANCE WITH THE STANDARD FOR VENTILATION CONTROL AND FIRE PROTECTION OF COMMERCIAL COOKING OPERATIONS, N.F.P.A. 96 (current edition).

3-MONTH MAINTENANCE:

Thoroughly clean entire HOOD PLENUM and BLOWER section.

6-MONTH MAINTENANCE:

Inspection and testing of total operation including FIRE DAMPER and all SAFETY INTERLOCKS shall be performed by qualified service personnel.

All FIRE SUPPRESSION SYSTEM actuation components including MANUAL PULL STATION and any REMOTE MANUAL PULL STATION must be inspected for proper operation in accordance with the maintenance schedule published in ANSUL® R-102 SYSTEM DESIGN, INSTALLATION, RECHARGE AND MAINTENANCE MANUAL (418087).

On WVAE-Model fryers, open the rear cover access door and lubricate the LIFT WORM threads with molybdenum disulfide grease (see item v.15 page 2) .

ANNUAL (12-MONTH) MAINTENANCE:

FIRE SUPPRESSION SYSTEM FUSIBLE LINKS must be replaced.

NOZZLES and MANUAL PULL STATION must be cleaned in accordance with ANSUL® R-102 SYSTEM DESIGN, INSTALLATION, RECHARGE AND MAINTENANCE MANUAL (418087).

12-YEAR MAINTENANCE:

The FIRE SUPPRESSION AGENT TANK and ¼" FLEX HOSE must be HYDROSTATICALLY TESTED, and the FIRE EXTINGUISHING AGENT must be REPLACED in accordance with the maintenance schedule published in ANSUL® R-102 SYSTEM (STANDARD UL 300 LISTED). This maintenance to be performed by qualified Ansul® service personnel only.

TROUBLESHOOTING SUGGESTIONS

| Problem | Possible Cause | Suggested Remedy |
|---|---|--|
| Unit will not operate (no indicators lights lit) | Disconnected from electric power | Reconnect to electric power Reset circuit breaker for unit |
| Unit will not operate (buzzer sounds) | Fire suppression system not set | Contact an authorized Ansul® distributor for repairs |
| CHECK FILTER light lit | HEPA air filter or grease baffle not in position | Properly install HEPA filter and grease baffle |
| REPLACE FILTERS light lit | HEPA air filter and charcoal filters nearing end of service life | Arrange to replace both HEPA and charcoal filters in a timely manner |
| SERVICE REQUIRED light lit (fryer not operating) | HEPA air filter and charcoal filters plugged | Replace both HEPA and charcoal filters |
| | Fire damper in exhaust collar has closed | Contact an authorized Wells service agent for repairs |
| | One or more vacuum sensing lines or ports plugged | Contact an authorized Wells service agent for repairs |
| | NOTE: If, after 10 seconds, there is insufficient airflow for proper operation, SERVICE REQUIRED light will illuminate and fryer will be de-energized. Press FRYER POWER SWITCH to <i>OFF</i> , then back to <i>FRYER</i> to reset system. | |

NOTE:

FILTERS are the only user serviceable components in this ventilator hood system. For all problems that cannot be remedied by servicing the filters, contact:

Fryer or ventilator section - authorized Wells service agency

Fire suppression system - authorized Ansul® distributor

IMPORTANT:

Contact ANSUL® for fire suppression system installation, set-up and service:

Ansul Incorporated

1-800-TO-ANSUL (1-800-862-6785)

One Station Street

Marinette, WI 54143-2542

website <http://www.ansul.com>

IMPORTANT:

Parts used in the Ansul® fire suppression system are not serviceable by the owner/operator.

Procedures for servicing fire suppression equipment are described in:

ANSUL® R-102 SYSTEM DESIGN, INSTALLATION, RECHARGE AND MAINTENANCE MANUAL
(418087, current edition)

NOTE:

ANSUL® Manual 41807 and Wells Bulletin 301646 are intended for use by authorized Ansul® service personnel only.

