



SOLUTIONS

WELLS BLOOMFIELD, LLC
265 Hobson St. • Smithville, TN 37166
telephone: (800) 264-7827
wells-mfg.com

527



OWNERS MANUAL

**VENTLESS UNIVERSAL
HOOD SYSTEM
for
ELECTRIC
COOKING
APPLIANCES**

**MODEL
WVU72**

**Manual Includes
INSTALLATION
USE & CARE
EXPLODED VIEW
PARTS LIST
WIRING DIAGRAM**

IMPORTANT: DO NOT DISCARD THIS MANUAL

This manual is considered to be part of the appliance and is to be given to the OWNER or MANAGER of the restaurant, or to the person responsible for TRAINING OPERATORS of this appliance. Additional manuals are available from your WELLS DEALER.

THIS MANUAL MUST BE READ AND UNDERSTOOD BY ALL PERSONS USING OR INSTALLING THIS APPLIANCE. Contact your WELLS DEALER if you have any questions concerning installation, operation or maintenance of this equipment.

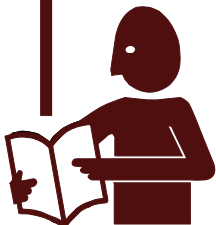

LIMITED WARRANTY STATEMENT

LIMITED EQUIPMENT WARRANTY

Wells Manufacturing warrants to the original purchaser of new Wells products to be free from defects in material or workmanship, under normal and proper use and maintenance service as specified by Wells and upon proper installation and start-up in accordance with the instructions supplied with each Wells unit. Wells' obligation under this warranty is limited to a period of one [1] year from the date of original installation, or eighteen [18] months from original invoice date, whichever occurs first. Defects that occur as a result of normal use, within the time period and limitations defined in this warranty, will at Wells' discretion have the parts replaced or repaired by Wells or a Wells-authorized service agency.

THIS WARRANTY IS SUBJECT TO ALL LISTED CONDITIONS

Repairs performed under this warranty are to be performed by a Wells authorized service agency. Wells will not be responsible for charges incurred or service performed by non-authorized repair agencies. In all cases, the nearest Wells-authorized service agency must be used. Wells will be responsible for normal labor charges incurred in the repair or replacement of a warrantied product within 50 miles (80.5 km) of an authorized service agency. Time and expense charges for anything beyond that distance will be the responsibility of the owner. All labor will need to be performed during regular service hours. Any overtime premium will be charged to the owner. For all shipments outside the U.S.A. and Canada, please see the International Warranty for specific details. It is the responsibility of the owner to inspect and report any shipping damage claims, hidden or otherwise, promptly following delivery. No mileage or travel charges will be honored on any equipment that is deemed portable. In general, equipment with a cord and plug weighing less than 50 lb. (22.7 kg) is considered portable and should be taken or shipped to the closest authorized service agency, transportation prepaid.

CONTACT

Should you require any assistance regarding the operation or maintenance of any Wells Manufacturing; phone or email our service department. In all correspondence provide the model number and serial number of the unit needing service; include the voltage or gas type.

Normal Business Hours: 8:00 a.m. to 4:30 p.m. Central

Telephone: 800-264-7827 Tech Service Option 2

Email: TechService@partstown.com

www.Wells-Mfg.com

PRODUCTS	PARTS	LABOR
Universal Ventless Hoods (WVU)	1 year	1 year
Canopy Ventless Hoods (WVC)	1 year	1 year
"Cook and Hold" equipment (HW10, HWSMP, LLSC7, LLSC7WA, LLSC11, LLSC11WA)	1 years	1 year
Cast iron grates, burners and burner shields	1 year	
Original Wells parts sold to repair Wells Equipment	90 days	

WARRANTY EXCLUSIONS

THE FOLLOWING WILL NOT BE COVERED UNDER WARRANTY.

Wells' sole obligation under this warranty is limited to either repair or replacement parts, subject to the additional limitations detailed below. This warranty neither assumes nor authorizes any person to assume obligations other than those expressly covered by this warranty.

- Any product which has not been used, maintained, or installed in accordance with the directions published in the appropriate installation sheet and/or owner's manual, including incorrect gas or electrical connection. Wells is not liable for any unit which has been mishandled, abused, misapplied, subjected to harsh chemicals, modified by unauthorized personnel, damaged by flood, fire, or other acts of nature [or God], or which have an altered or missing serial number.
- Installation, labor, and job checkouts, calibration of heat controls, air and gas burner/bypass/pilot adjustments, gas or electrical system checks, voltage and phase conversions, cleaning of equipment, or seasoning of griddle surface.
- Replacement of fuses or resetting of circuit breakers, safety controls, or reset buttons.
 - Replacement of broken or damaged glass components, quartz heating elements, and light bulbs.
- Labor charges for all removable and consumable parts in gas charbroilers and hotplates, including but not limited to burners, grates, and radiants.
- Any labor charges incurred by delays, waiting time, or operating restrictions that hinder a service technician's ability to perform service.
- Replacement of parts that fail or are damaged due to normal wear or labor for replacement of parts that can be replaced during a daily cleaning routine, such as but not limited to silicone belts, PTFE non-stick sheets, control labels, knobs, bulbs, fuses, quartz heating elements, baskets, racks, and grease drawers.
- Any economic loss of business or profits.
- Non-OEM parts. Use of non-OEM parts without Wells' approval will void the warranty.
- Units exceeding one [1] year from original installation date, or more than eighteen [18] months from original invoice date, whichever comes first.

ADDITIONAL WARRANTIES

- Specific/chain-specific equipment may have additional and/or extended warranties.

The foregoing warranty is in lieu of any and all other warranties expressed or implied and constitutes the entire warranty.

TABLE OF CONTENTS

WARRANTY	xi
ELECTRICAL SPECIFICATIONS	1
WARNINGS - ENGLISH	2
WARNINGS - FRENCH	3
FEATURES & OPERATING CONTROLS	4-5
PRECAUTIONS & GENERAL INFORMATION	6
INSTALLATION	7
Unpacking & Inspection	7
Components	7
Under-Hood Appliance Limitations	8-9
Service Technician Installation Notes	10
Base Assembly	11-13
Electrical Installation	14-15
ANSUL® INSTALLATION & SETUP	16-17
Filter Installation	18
OPERATION	19
Operation Lights	19
CLEANING INSTRUCTIONS	20-21
REQUIRED MAINTENANCE & MAINTENANCE LOGS	22-27
TROUBLESHOOTING SUGGESTIONS	28
WIRING DIAGRAM	29
EXPLODED VIEW & PARTS LIST	30-38
PARTS & SERVICE	39-40
CUSTOMER SERVICE DATA	41

INTRODUCTION

Thank You for purchasing this Wells Manufacturing appliance.

Proper installation, professional operation and consistent maintenance of this appliance will ensure that it gives you the very best performance and a long, economical service life.

This manual contains information and instructions for the ventless ventilation hood, its use and care.

For information regarding cooking appliance(s), please refer to the manufacturer's operation manual.

Note: Wells Ventless does not qualify for free prepaid freight. Wells Ventless is made to order and is non-refundable.

ELECTRICAL SPECIFICATIONS

Model	Volts	Amps	Hz	Phase	HP	Typical Airflow	Max Greasse Emissions	Clearance to Combustibles	Under Hood LED Lighting
WVU72	208/240V	3.5	60	1	1.0	1500 CFW	.0029 lb/hr/ft	N/A	2000 Lumens

WARNINGS - ENGLISH

IMPORTANT: DO NOT DISCARD THIS MANUAL

This manual is considered to be part of the appliance and is to be given to the OWNER or MANAGER of the restaurant, or to the person responsible for TRAINING OPERATORS of this appliance. Additional manuals are available from your WELLS DEALER.

THIS MANUAL MUST BE READ AND UNDERSTOOD BY ALL PERSONS USING OR INSTALLING THIS APPLIANCE. Contact your WELLS DEALER if you have any questions concerning installation, operation or maintenance of this equipment.



DANGER FIRE HAZARD

Fire suppression system must be charged and certified by an authorized Ansul® distributor.

DO NOT attempt to modify or bypass the fire suppression & filter systems. Doing so will void all warranty and create an unsafe operating condition.

An uncontrolled fire can cause serious injury or death.

WARNING:

If the fire suppression system is discharged, a buzzer will sound continuously. The unit will remain inoperable until the fire suppression system is serviced, recharged and reset by an authorized Ansul® distributor. Should the fire suppression system discharge, contact the technical service team:(800)-264-7827 All lines and nozzles must be thoroughly cleaned prior to recharging the system. Ansul Deployments are not covered under warranty. Technical service needs to be contacted immediately and a deployment kit of parts needs to be replaced before unit is put back in service. WSWL0964 Deploymnt kit, WVU

NOTE:

If a REMOTE MANUAL PULL STATION is installed, moving the ventilator for any reason may cause the Ansul® system to discharge.



DANGER - DO NOT BLOCK ACCESS TO THE FIRE EXTINGUISHING MANUAL PULL.

DANGER: SUFFOCATION HAZARD

“Do not attempt to use this ventilator with gas-fired units. This ventilator will not remove products of combustion. Unvented exhaust gasses can be deadly.”



WARNING: SHOCK HAZARD

All servicing requiring access to non-insulated electrical components must be performed by a factory authorized technician.

DO NOT open any access panel which requires the use of tools. Failure to follow this warning can result in severe electrical shock.



WARNING: RISK OF INJURY

Installation procedures must be performed by a qualified technician with full knowledge of all applicable electrical codes. Failure can result in personal injury and property damage.

WARNING: SLIP AND FALL HAZARD

DO NOT operate any grease-producing cooking appliance unless the grease cup is properly installed. Oil will drip onto floor creating a slipping hazard.

WARNING:

DO NOT attempt to wash the HEPA / CHARCOAL filter pack or pre-filter. Water absorption will render the filter unusable. Use of a wet or clogged filter will cause the ventilator system to shut down. Use only new, clean Wells® Authorized Service Parts. Keep spare filter packs on hand to avoid distrupions.

Service Department (800) 264-7827.

Exposed surfaces can be hot to the touch and may cause burns. Allow unit to cool before cleaning or servicing.

WARNINGS - FRENCH

IMPORTANT : NE JETEZ PAS CE MANUEL

Ce manuel fait partie intégrante de l'appareil et doit être remis au PROPRIÉTAIRE, au GÉRANT du restaurant ou au responsable de la FORMATION DES UTILISATEURS. Des manuels supplémentaires sont disponibles auprès de votre concessionnaire WELLS.

TOUTE PERSONNE INSTALLANT OU UTILISANT CET APPAREIL DOIT LIRE CE MANUEL ET S'ASSURER DE L'AVOIR COMPRIS.

Veuillez contacter votre CONCESSIONNAIRE WELLS pour toute question concernant l'installation, l'utilisation ou l'entretien de cet équipement.



DANGER RISQUE D'INCENDIE

Le système anti-incendie doit être chargé et certifié par un distributeur agréé Ansul®. N'essayez PAS de modifier ou de contourner le système anti-incendie. Un feu hors de contrôle risque de provoquer des blessures graves, voire mortelles.

AVERTISSEMENT :

Une alarme sonore se déclenche en continu si le système anti-incendie est déchargé. L'unité reste inutilisable jusqu'à ce qu'un distributeur agréé Ansul® effectue son intervention, le recharge et le réinitialise.

REMARQUE :

Si un AVERTISSEUR D'INCENDIE À DISTANCE MANUEL est installé, tout déplacement du ventilateur, quel qu'en soit le motif, peut provoquer la décharge du système Ansul®.

DANGER - NE PAS BLOQUER L'ACCÈS À LA POIGNÉE DE L'EXTINCTEUR !



DANGER : RISQUE DE SUFFOCATION

“Ce ventilateur ne doit pas être utilisé avec des appareils à gaz. Il n'absorbe pas les produits de combustion. En l'absence de sortie d'aération, les gaz de combustion peuvent être mortels.”



AVERTISSEMENT : RISQUE DE DÉCHARGE ÉLECTRIQUE

Toute intervention nécessitant d'accéder à des composants électriques non isolés doit être effectuée par un technicien agréé usine.

N'ouvrez AUCUN panneau d'accès nécessitant l'utilisation d'un outil. Le non-respect de cet avertissement peut exposer à une décharge électrique sévère.



AVERTISSEMENT : RISQUE DE BLESSURE

Les procédures d'installation doivent être effectuées par un technicien qualifié ayant pleine connaissance des réglementations applicables. Le non-respect de cet avertissement peut provoquer des blessures et des dommages matériels.

AVERTISSEMENT : RISQUE DE CHUTE

N'utilisez PAS d'appareil de cuisson produisant de la graisse sans que le godet à graisse soit correctement installé. Vous risqueriez de glisser car la graisse éclabousserait le sol.

AVERTISSEMENT :

N'essayez PAS de nettoyer le filtre ou le pré-filtre HEPA ou à CHARBON. L'eau absorbée rendrait le filtre inutilisable. Un filtre humide ou colmaté provoque l'arrêt du système de ventilation. Utilisez uniquement des pièces neuves et propres, homologuées par Wells®. Conservez des filtres de rechange pour éviter l'interruption du fonctionnement.

Service clientèle : (800) 264-7827.

FEATURES & OPERATING CONTROLS

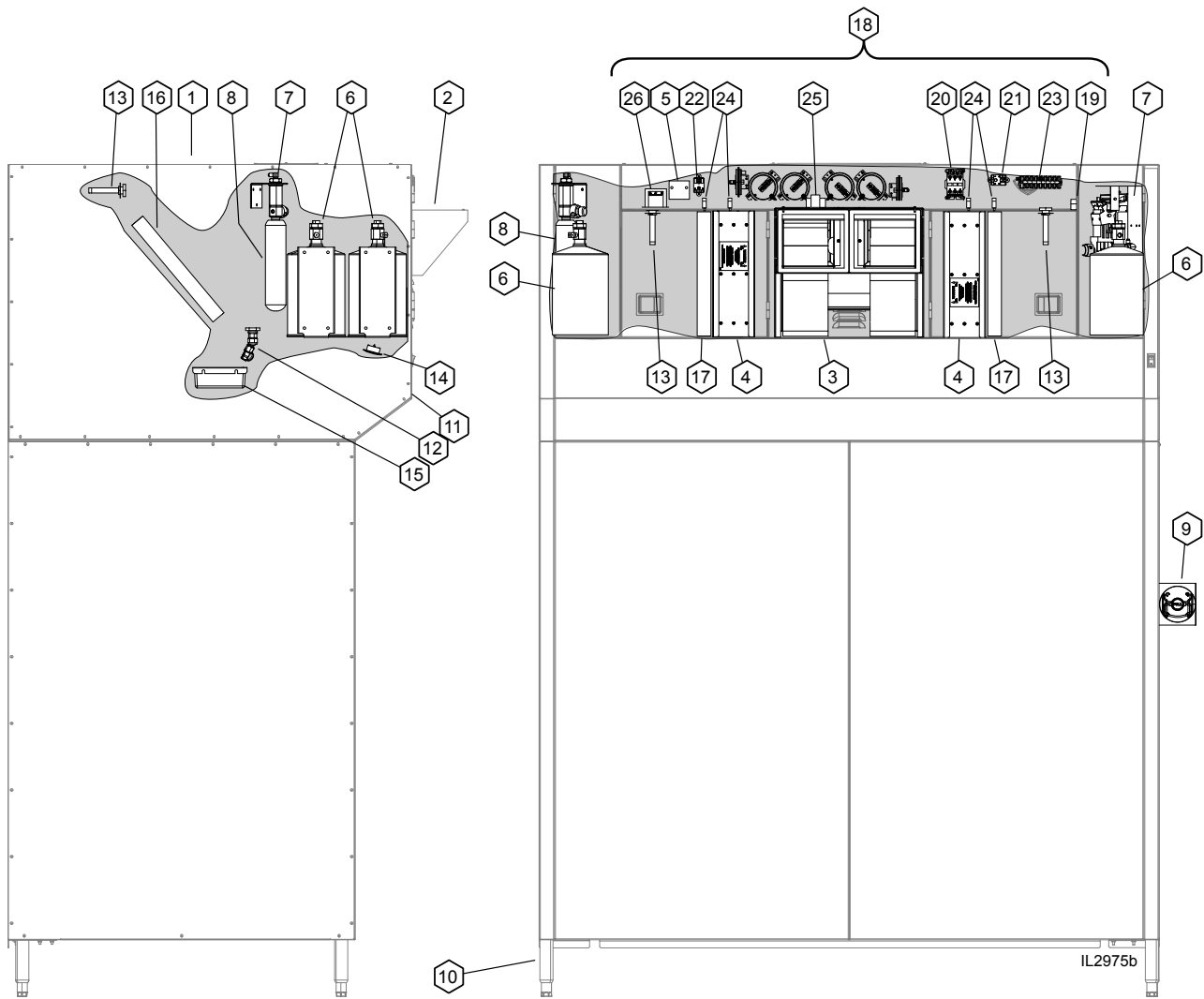

Ventilator Section Operating Features & Controls

FEATURES & OPERATING CONTROLS continued

FEATURES & OPERATION CONTROLS		
ITEM NO	DESCRIPTION	COMMENT
1	VENTILATOR EXHAUST DUCT, TOP	Exit point for ventilator airflow - on top of unit. DO NOT BLOCK
2	VENTILATOR EXHAUST DUCT, FRONT	Exit point for ventilator airflow - on front of unit. DO NOT BLOCK
3	VENTILATOR FAN	Provides air movement for ventilation
4	HI-EFFICIENCY/CHARCOAL FILTER PACK	Removes grease and smoke particles. Also assists in cooking odor removal.
5	NAMEPLATE	Gives manufacturer, make and model description. Also list voltage and amperage data.
6	FIRE SUPPRESSION TANK	Container for ANSUL® Low-pH Liquid fire suppression fluid.
7	ACTUATOR ASSY	Triggers deployment of suppression fluid through manual pull station or electric detection.
8	ANSUL® CARTRIDGE	Propels suppression liquid through suppression manifold and nozzles.
9	MANUAL PULL STATION	Provides a means of manual activation of the fire suppression system. PULL ONLY IN CASE OF FIRE!
10	ADJUSTABLE LEGS	Allows the unit to be leveled.
11	AIR WALL	A wall of air that moves the grease and smoke particles into the filter system.
12	DISCHARGE NOZZLES	Fire suppression media discharges here, (10 places)
13	ELECTRICAL DETECTORS	Designed to activate at certain temperature. Activates (i.e. fire on the cooktop) activates fire suppression system. Should be checked every 6 months during ANSUL® Service Inspection
14	APPLIANCE LIGHT	ON when hood power switch is ON. Illuminates cooking area.
15	GREASE DRIP TRAY	Collects grease/moisture dripping from baffle filter (16)
16	BAFFLE FILTER	Extracts and drains most greases and moisture from the air flow.
17	PRE-FILTER ASSEMBLY	Stops large particles of grease from reaching the FILTER PACK for reduced maintenance costs.
18	ELECTRICAL CONNECTION BOX	Houses electrical components
19	GROUND LUG	Ground wire of power connection connects here.
20	EQUIPMENT INTERFACE CONTACTOR	Energizes cooking appliances only while ventilator section is sensed as operational.
21	BUILDING FIRE ALARM RELAY	Reports fire alarm condition to building fire management system.
22	DETECTION END OF LINE RELAY	Prevents appliance operation if a fault is found in detection circuit.
23	SUPPLY CONNECTION TERMINAL BLOCK	Provides connection point for electrical circuitry
24	FILTER INTERLOCK SWITCHES	Proper installation of baffle filter and filter pack closes these switches in ventilator sensor circuit
25	12V TRANSFORMER	Provides power to the LED spot lights.
26	120V TRANSFORMER	Provides power to the 5 temperature sensors for the fire suppression system.

PRECAUTIONS AND GENERAL INFORMATION



DANGER: **SUFFOCATION HAZARD**

Do not attempt to use this ventilator with gas-fired units. This ventilator will not remove products of combustion. Unvented exhaust gasses can be deadly.



WARNING: **SHOCK HAZARD**

All servicing requiring access to non-insulated electrical components must be performed by a factory authorized technician.

DO NOT open any access panel which requires the use of tools. Failure to follow this warning can result in severe electrical shock.

IMPORTANT:

The ventilator is disabled when the filters are plugged to the point of insufficient airflow for proper operation. Also, power to the cooking appliances is interrupted if any filters or service panel are removed.

It is the responsibility of the store management to maintain sufficient spares of filter packs to avoid prolonged shutdown due to a dirty or clogged filter pack. Filter packs cannot be cleaned.

Wells Manufacturing assumes no liability for loss of business due to a filter related shutdown. Spare filters can be purchased from any authorized Wells servicer or calling Wells.

This ventilator hood is part of an engineered system and is intended for use in commercial establishments only.

This ventilator is intended for commercial establishments for use in the preparation food for human consumption. No other use is recommended or authorized by the manufacturer or its agents.

Operators of this appliance must be familiar with the appliance use, limitations and associated restrictions. Operating instructions must be read and understood by all persons using or installing this appliance.

This ventilator hood system is designed to reduce odor emissions, but will not completely eliminate all cooking odors. Air exchange rates at the installation site must comply with the requirements of the local jurisdictional authority. To ensure that odors do not accumulate, recommended minimum of 200 cubic feet of fresh air per linear foot of hood is required into the area to comply with the universal mechanical code and for the dilution of cooking aromas.

This unit is intended for use with light- and medium duty electric cooking appliances only. Cooking appliances placed under this ventilator must comply with the restrictions set forth in the *Installation section of this manual*.

Do not connect or energize this appliance until all installation instructions are read and understood. Property damage or bodily injury may result if these instructions are not followed. Disconnect this appliance from electrical power before performing any maintenance or servicing.

Cleanliness of this appliance is essential to good sanitation. Read and follow all included cleaning instructions and schedules to ensure the safety of the food product.

This appliance is not jet steam approved. Do not clean unit using direct water jet or steam jet at this appliance, or at any control panel or wiring. Do not splash or pour water on, in or over any controls, control panel or wiring. Do not attempt to wash filter packs. Water will cause their immediate failure and disable the ventilator.

Exposed surfaces of this appliance can be hot to the touch and may cause burns.

Avoid storing flammable or combustible materials in, on or near the ventilator or associated cooking appliance.

The technical content of this manual, including any wiring diagrams, schematics, parts breakdown illustrations and/or adjustment procedures, is intended for use by qualified technical personnel.

Any procedure which requires the use of tools must be performed by a qualified technician.

All supplied instructions, diagrams, schematics, parts breakdown illustrations, notices and labels must remain with the appliance if the unit is sold or moved to another location.

This appliance is made in the USA. Unless otherwise noted, this appliance has American sizes on all hardware.

INSTALLATION

UNPACKING & INSPECTION

Carefully remove the appliance from the carton. Remove all protective plastic film, packing materials and accessories from the appliance before connecting electrical power or otherwise performing any installation procedure.

Carefully read all instructions in this manual and any other documents packed with the appliance before starting any installation. All documentation should remain with the equipment operator for future reference.

Read and understand all labels and diagrams attached to the ventilator.

Carefully account for all components and accessories before discarding packing materials.

COMPONENTS 6 ft

Pre-Filter	2 ea.
Baffle Filter	3 ea.
Filter pack	2 ea.
Grease cup	1 ea.

Ansul® components - must be installed by an authorized Ansul® distributor only:

6 ft

- 3 ea.** Fire suppression agent tank
- 3 ea.** Fire suppression agent (Ansulex® Low pH) 1.5 gal.
- Fire suppression system charging cartridge
- 1 ea.** LT-30R; 30 Liter cartridge
- 1 ea.** LT-20R; 20 Liter cartridge

Store these components in a convenient place for later use.

The unit is shipped configured for vertical discharge of the exhaust.

NOTE: An optional angled discharge is available, see Parts & Service section of the manual.

NOTE: DO NOT discard the carton or other packing materials until you have inspected the appliance for hidden damage and tested it for proper operation. Refer to *SHIPPING DAMAGE CLAIM PROCEDURE* on the inside front cover of this manual.



WARNING: RISK OF INJURY

Installation procedures must be performed by a qualified technician with full knowledge of all applicable electrical codes. Failure can result in personal injury and property damage.

IMPORTANT:

Fire suppression system must be charged and certified by an authorized Ansul® distributor. Ventilator will not operate and cooking appliance will not be energized until the Ansul® fire suppression system has been charged.

IMPORTANT:

After cooking appliances are positioned under the hood, swivel nozzles must be positioned per Ansul® recommendations.

INSTALLATION (continued)

UNDER-HOOD APPLIANCE LIMITATIONS:

GENERAL LAYOUT DATA
SANITATION

MODEL WVU-72 UNIVERSAL VENTLESS HOOD SYSTEM



VOLTAGE AC 60 HZ	AMPS 1 PH.	HORSE POWER	TYPICAL AIRFLOW	MAX. GREASE EMMISSIONS	CLEARANCES TO COMBUSTIBLES	UNDER HOOD LED LIGHTING
208/240	3.5	1.0	1500 CFM	.0029 LB/HR/FT	SEE DRAWING	2000 LUMENS

NSF/ANSI 2 UL710B

UL CAT. YZCT RECIRCULATING SYSTEM FILE NO. MH48408

SPECIAL ENVIRONMENTAL NOTICE: THE HOOD SYSTEM IS DESIGNED TO REDUCE EMISSIONS BUT WILL NOT COMPLETELY ELIMINATE COOKING AROMAS. AIR EXCHANGE AT THE INSTALLATION SITE MUST COMPLY WITH REQUIREMENTS OF THE LOCAL JURISDICTIONAL AUTHORITY. A MINIMUM OF 1200 CUBIC FEET OF FRESH AIR PER MINUTE INTO THE AREA IS RECOMMENDED TO ENSURE ADEQUATE DILUTION.

HOOD SYSTEM INSTALLATION – STAND MOUNT – REGARDLESS OF EQUIPMENT UNDER HOOD.

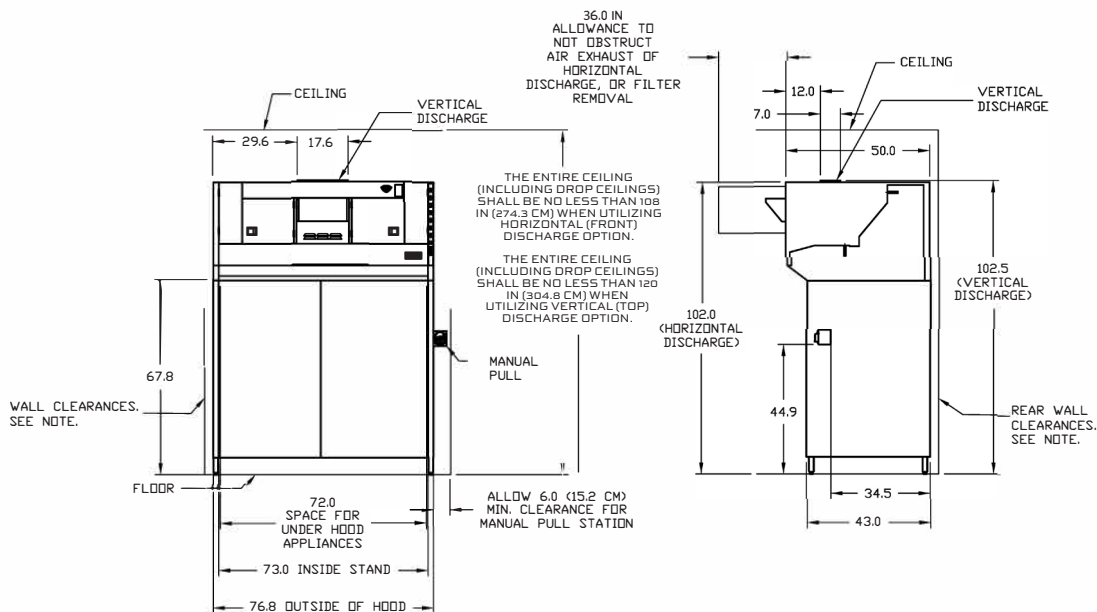

NOTE(S).

1. WALL CLEARANCES REFERENCE NFPA 96, CLAUSE 4.2.1. AT LEAST 18 IN. (457 MM) TO COMBUSTIBLE MATERIALS; 3 IN. (76 MM) TO LIMITED-COMBUSTIBLE MATERIALS, AND 0 IN. (0MM) TO NONCOMBUSTIBLE MATERIAL.

Table: Weights and Shipping Information

Weights				Carton Dimensions						Crate Size	
Shipping Weight		Installed Weight		Width		Depth		Height		Crate Size	
Pounds	kg	Pounds	kg	Inches	mm	Inches	mm	Inches	mm	Cubic Feet	Cubic Meters
1632	740	850	386	120	3048	63	1600	53.5	1359	234	6.63

THE HOOD AND ALL UNDER HOOD APPLIANCES MUST BE INSTALLED IN ACCORDANCE WITH THE STANDARD FOR VENTILATION CONTROL AND FIRE PROTECTION OF COMMERCIAL COOKING OPERATIONS NFPA 96, THE NATIONAL ELECTRIC CODE NFPA 70 AND ALL LOCAL CODES WHERE APPLICABLE. ALL UNDER HOOD APPLIANCES MUST BE INSTALLED AS PER MANUFACTURER INSTRUCTIONS AND CONTROLLED BY THE HOOD EQUIPMENT SHUTOFF INTERFACE THROUGH A CUSTOMER SUPPLIED CONTACTOR. SEE THE INSTRUCTION MANUAL FOR INTERFACE CONNECTION OPTIONS. APPLIANCES MUST MEET EQUIPMENT PARAMETERS DESCRIBED ABOVE. ONLY ELECTRICALLY HEATED APPLIANCES ARE ACCEPTABLE FOR INSTALLATION. PRIOR TO OPERATION THE FIRE SUPPRESSION SYSTEM MUST BE CHARGED AND CERTIFIED BY AN ANSUL® AUTHORIZED DISTRIBUTOR. ADEQUATE SIDE CLEARANCE MUST BE PROVIDED FOR SUPPLY CONNECTION AND SUPPRESSION MANUAL PULL ACCESS. EXHAUST IS SHIPPED FOR HORIZONTAL DISCHARGE AND FIELD CONVERTIBLE FOR VERTICAL DISCHARGE.



WELLS MANUFACTURING
265 HOBSON ST
SMITHVILLE, TN 37166, USA

NOTE: SPECIFICATIONS SUBJECT TO CHANGE WITHOUT NOTICE.

SK2846 REV D (08-22)

INSTALLATION (continued)

UNDER-HOOD APPLIANCE LIMITATIONS:

1. Appliance must be installed per manufactures instructions.
2. Electrical appliances only. Not Intended for gas fired units.
3. All appliances under the hood must be connected to the hood appliance interlock circuit.
4. All appliances must meet the requirements outlined in the cooking appliance limitations chart below.

COOKING APPLIANCE LIMITATIONS

Coverage Parameters Appliance Type	Maximum kW/Ft	Max Cooking Temperature °F	Maximum Single Appliance Heated Cooking Surface Length	Dim "A" (3) Minimum	Dim "B" (4) Minimum	Dim "B" (4) Maximum	Dim "C" (3) Minimum
Fryer	17.0	400	18	24"	37"	42"	0
Griddle	5.5	450	36	21"	30"	38"	1"
Range/Hotplate	5.5	N/A	48	18"	37"	42"	0
WOK	7.0	N/A	48	21"	37"	42"	0
Vertical Broiler	7.0	N/A	25	20"	10"	N/A	0
Oven	N/A	575	48	6"	8"	N/A	0
Braising Pan/Skillet (1)	4.5	550	48	14"	37"	42"	0
Convection Oven	N/A	575	48	6"	8"	N/A	0
Sandwich Grill	4.5	550	48	18"	37"	42"	0
Steam Jacketed Kettle	16.9	450	48	14"	30"	42"	0
Conveyor Oven	4.5	N/A	23	6"	8"	42"	0

- (1) Lid must not interfere with suppression nozzle discharge pattern.
- (2) Plus oven kW if applicable.
- (3) Front of hood to front edge of heated cooking surface.
- (4) Bottom front edge of hood to height of heated cooking surface.
- (5) Inside of hood side to edge of cooking surface.
- (6) Maximum front opening.

Intended for installation in accordance with:

The standard for ventilation control and fire protection of commercial cooking operations NFPA 96, the National Electric Code NFPA 70 and local codes where applicable.

Only electrically heated appliances are acceptable for installation. Appliance Operation Requires the Fire suppression system be setup, charged and certified by an authorized ANSUL® distributor. The airflow monitoring system will prevent appliance operation if insufficient airflow is detected or all filters are not in place. The service panel must be in place for blower operation.

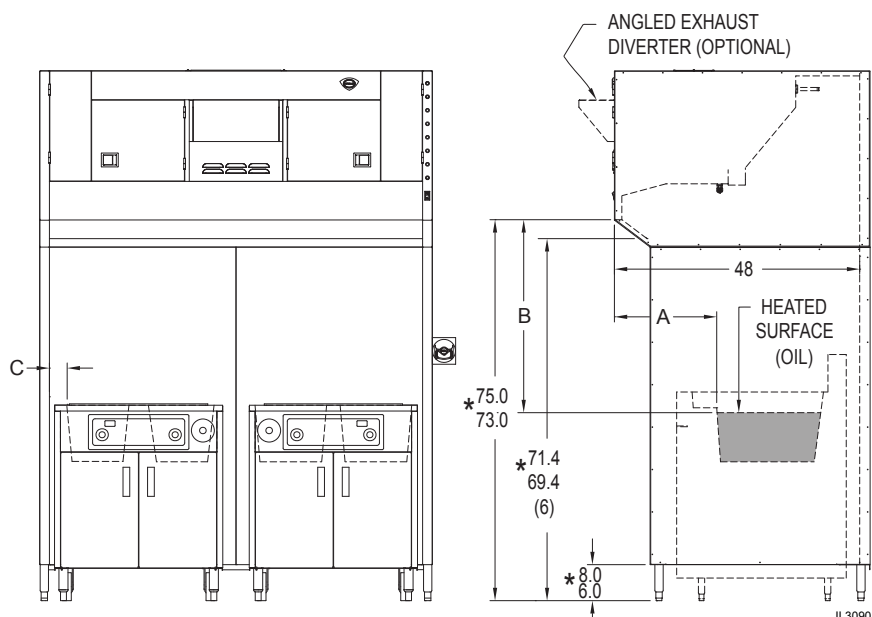

* THE 10" TO 12" LEG OPTION INCREASES OVERALL VERTICAL DIMENSIONS BY UP TO 4" ALLOWING TALLER EQUIPMENT TO BE USED UNDER THE HOOD. "B" EQUIPMENT PARAMETERS STILL APPLY.

INSTALLATION (continued)

SERVICE TECHNICIAN INSTALLATION NOTES

This ventilator hood is to be used with light-duty and medium-duty electrically powered cooking appliances only.

- DO NOT attempt to use this ventilator hood with gas-fired units.
- DO NOT use this ventilator hood with electrical appliances whose dimensions or wattage characteristics exceed those defined in the Under Hood Cooking Appliance Limitations, page 8.

Installation and start up must be performed by an Authorized Installation Company.

Ansul® Installer must complete the WARRANTY INITIATION form (2M-303912) included with the unit for the warranty to begin, and record installation particulars on the CUSTOMER SERVICE DATA form located at the end of this manual.

IT IS THE RESPONSIBILITY OF THE INSTALLER TO verify that this VENTILATOR installation is in compliance with the specifications listed in this manual, with local code requirements, and in accordance with N.F.P.A 96 the STANDARD FOR VENTILATION CONTROL AND FIRE PROTECTION OF COMMERCIAL COOKING OPERATIONS.

NOTE: Certain codes require FRYERS to be restrained with a TETHER or other RESTRAINT DEVICE. If this ventilator is to be used with a fryer, it is the RESPONSIBILITY OF THE INSTALLER to check with the AUTHORITY HAVING JURISDICTION, in order to ascertain the applicability of this requirement to this specific installation .

SETUP

Setup the appliance only on a firm, level, non-combustible surface. Verify local codes for requirements. Concrete, tile, terrazzo or metal surfaces are recommended. Metal over combustible material may not meet code for non-combustible surfaces.

Verify vertical clearances. The entire ceiling (including drop ceilings) shall be no less than 108 in (274.3 cm) when utilizing horizontal (front) discharge option. The entire ceiling (including drop ceilings) shall be no less than 120 in (304.8 cm) when utilizing vertical (top) discharge option.

Verify that the unit sits firmly on ALL LEGS. With a spirit level, check that the appliance is level front-to-back and side-to-side. With the adjustable legs, adjust as required to level the appliance. In order to prevent tipping or deflection, legs must be adjusted such that all legs are in firm contact with the floor.

NOTE: To ensure that odors do not accumulate, recommended minimum of 200 cubic feet of fresh air per linear foot of hood is required into the area to comply with the universal mechanical code and for the dilution of cooking aromas.



DANGER: SUFFOCATION HAZARD

Do not attempt to use this ventilator with gas-fired units. This ventilator will not remove products of combustion. Unvented exhaust gasses can be deadly.



WARNING: SHOCK HAZARD

All servicing requiring access to non-insulated electrical components must be performed by a factory authorized technician.

DO NOT open any access panel which requires the use of tools. Failure to follow this warning can result in severe electrical shock.



CAUTION: RISK OF DAMAGE

DO NOT connect or energize this appliance until all installation instructions are read and followed. Property damage or bodily injury could result if these instructions are not followed.

IMPORTANT:

If a remote pull station is to be used, ventilator cannot be moved without first disabling the remote pull station.

Contact your Ansul® agent for details.

INSTALLATION (continued)

To convert the discharge on the WVU-72 from vertical to front angled discharge, the blower must be removed and replaced with the blower outlet orientated in the horizontal position. An angled diverter is then added to direct the flow of discharge air to approximately 50 degrees from horizontal.

Warning: Ensure that all electrical power is disconnected from the unit before beginning this procedure.

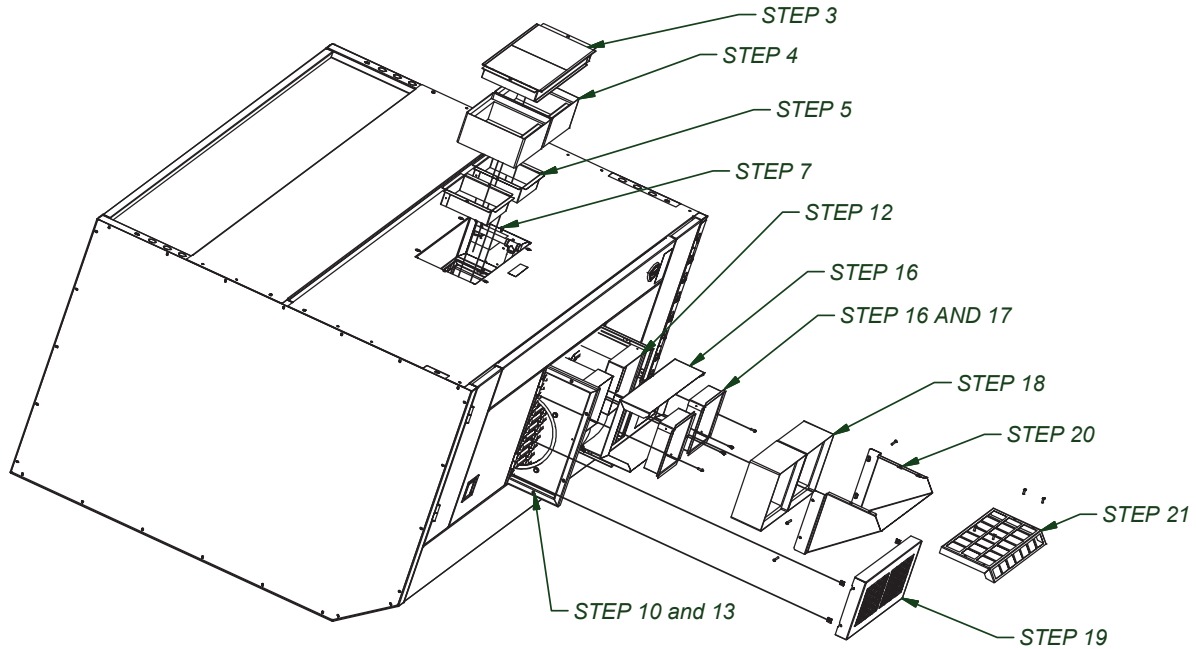

1. Remove left and right filter doors and remove both filter packs.
2. Remove the front center louvered panel by removing the four 1 1/4 inch long #8 screws securing the panel.
3. Remove the top screen assembly.
4. Remove and set aside the two dampers from under the top screen.
5. Remove the two sheet metal and two machine screws securing the two damper collars and set the collars aside.
6. Reinstall the two sheet metal screws to secure the damper box the top floor. Do not re-install the two machine screws.
7. Reinstall the top screen assembly using the two sheet metal screws originally used.
8. From the front of the unit, disconnect the electrical quick-connect leads from the blower.
9. Disconnect the clear tubing from the blower at the pressure tap ports noting which tube is on the left and right blower.
10. Remove the sixteen 1/4 inch bolts (8 each side of the blower) securing the blower assembly to the inner divider panel. Do not remove the eight (4 each side) bolts that secure the support plate to the blower.
11. Slide the blower assembly out of the unit taking care not to damage wires around the air curtain fan.
12. Reposition the blower so that the discharge is facing horizontally then slide the blower assembly back into the unit.
13. Re-install the sixteen 1/4 inch bolts (and washers) to secure the blower.
14. Re-connect the electrical wires to the blower and air curtain fan.
15. Re-connect the clear tubing to the blower tap ports making sure the left tube goes on the left blower as noted in step 9.
16. Install the new damper box (included in the kit) and the two damper collars (from step 5) to the blower support plates using the two 8-32 machine screws provided.
17. Install the two #8 sheet metal screws to secure the collars to the damper box.
18. Install the two dampers. (Note the installation orientation requirements listed on the damper.)
19. Assemble the lower front center screen using four 1 1/4 inch long #8 screws and # 8 clip nuts.
20. Assemble the front diverter panel using four 1 1/4 inch long machine screws.
21. Assemble the diverter screen to the diverter using four 8-32 x 12 screws provided.
22. Re-install all filters and filter packs and re-install the front doors.
23. The center louvered panel is no longer required.

INSTALLATION (continued)

Hardware Provided

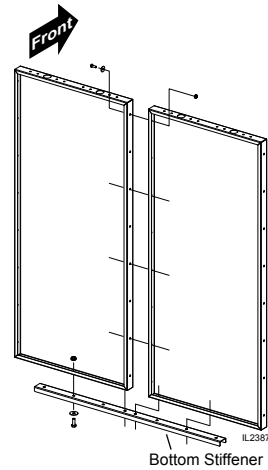
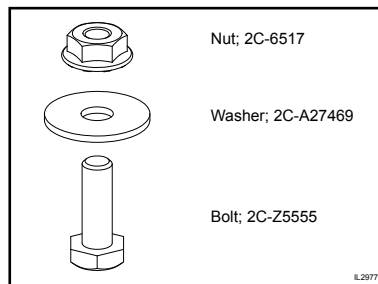

Figure 1

BASE ASSEMBLY

NOTICE: The hood **MUST** be raised using a vertical load only at the lift points. A telescope spreader bar lift or a spreader beam must be used.

Prior to assembling the base, locate it as close to the final position as possible. Then follow these steps.

1. Align the two rear panels (Fig 1) and secure with a bolt, washer and nut (8 places).
2. Place the Base Bottom Stiffener (N1-Z19038) to the bottom of the two rear panels and secure with bolt, washer and nut (8 places).
3. Align the left and right side of the base to the rear panel (Fig 2) and secure with bolt, washer and nut (8 places each side).
4. Align the rear corner brackets in place (Fig 3) and secure with bolt, washer and nut (4 places each bracket).
5. Install the 6" adjustable legs and secure in place with the bolt provided.

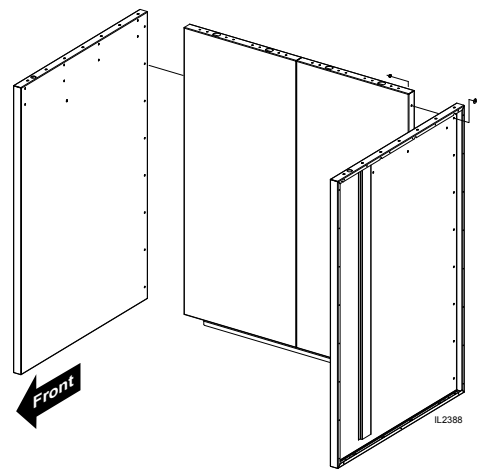

Figure 2

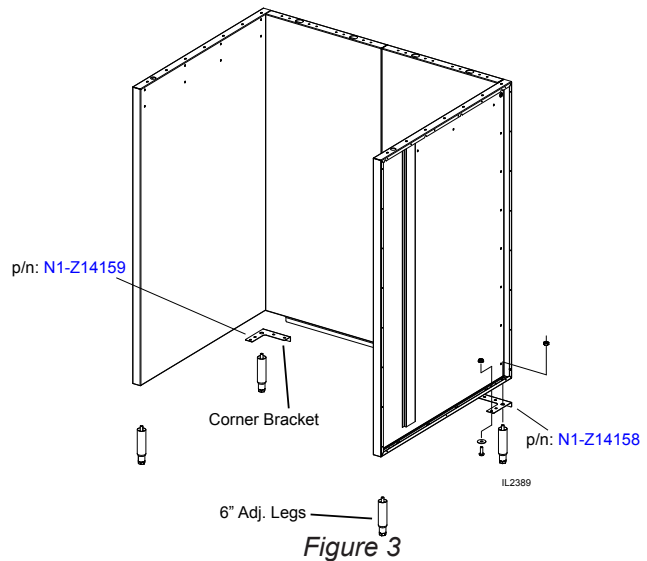

Figure 3

INSTALLATION (continued)

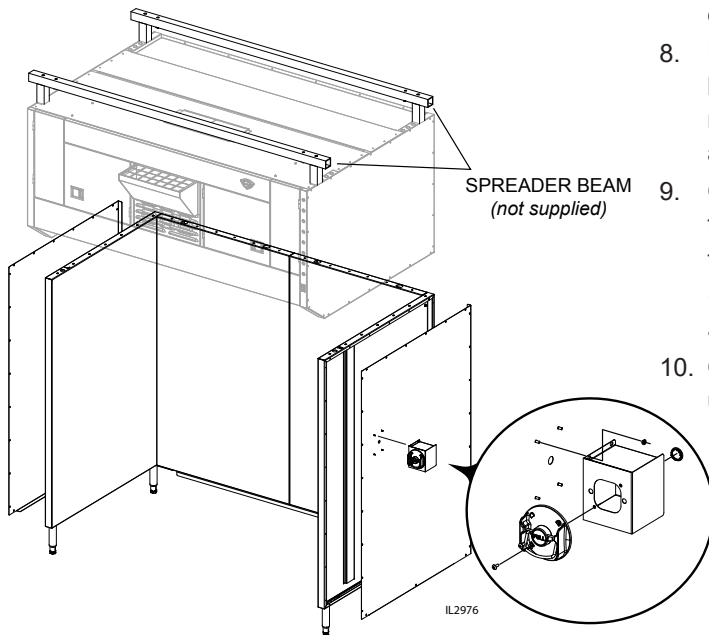

Figure 4

6. Move the base into position, and using a level, adjust the legs until level.
7. Remove the side panels of the hood assembly so when lowered onto the base assembly it will be easier to secure in place.
8. Use a spreader beam (not supplied) on the hood, lower the hood on top of the base (Fig 4) so the mounting holes line up. Secure with bolt, washer and nut (7 places each side).
9. Contact your electrical & Ansul® contractors to provide service to the system. Refer to the *ELECTRICAL INSTALLATION & FIRE SUPPRESSION SYSTEM INSTALLATION sections in this manual.*
10. Once complete the side panels can be installed using hardware provided.

INSTALLATION



DANGER: SUFFOCATION HAZARD

Do not attempt to use this ventilator with gas-fired units. This ventilator will not remove products of combustion. Unvented exhaust gasses can be deadly.



WARNING SHOCK HAZARD

Electrical connections must be made by a licensed electrician.



CAUTION: FIRE HAZARD HEALTH HAZARD

All cooking appliance must be connected to the cooking appliance contactor, the control circuit of which is controlled by the ventilator. **Note: Shunt trip breakers are not an authorized control circuit.** All appliances must be installed per the under hood limitations. Failure to control cooking appliances will provide no protection in the event of a fire, nor will cooking vapors and odors be contained in the event of ventilator hood malfunction.

ELECTRICAL INSTALLATION

Refer to the nameplate on the ventilator. Verify ELECTRICAL SERVICE POWER. Voltage and phase must match the nameplate specifications, and available electrical service amperage must meet or exceed the listed amperage. Refer to specifications listed on page 1 of this manual.

The ground lug of this ventilator must be connected to a suitable building ground.

Remove the front access panel to access the cooking appliance terminal block and building alarm relay. Remove the appropriate knockout, then wire the cooking appliance control circuit to the terminal block per Fig below.

NOTE: It is the responsibility of the electrical contractor to provide suitable wiring, flexible or rigid conduit, and an appropriate strain relief.

Electrical Connection

NOTE: The hood requires a single phase (1ph), 208 or 240 volt, 20 amp supply. When connecting line voltage to the unit's terminal block, use a minimum of #12 gage copper wire only, suitable for 167°F (76°C) ambient temperature.

Appliance Connections

All under hood appliances are required to be interlocked with the hood's equipment cut-off circuit, through a customer supplied contactor. This contactor must be a UL listed, definite purpose AC resistive air heating type, suitable for the appliance load. Installation and connections shall be in accordance with the National Electric Code NFPA 70. These connections provide an automatic shutdown of the appliance when the hood is OFF, or in the event of a malfunction or appliance fire.

Equipment Cutoff Connections

Opt 1: Use TB#3 & TB#4 for 208 or 240 volt control circuit. These contacts will be de-energized when the hood is OFF or in the event of a malfunction

Opt 2: Use TB#5 & TB#6 as a Normally Closed SPST relay connection for equipment control circuits with voltages other than 208 or 240 AC. These contacts will be open when hood is OFF or in the event of a malfunction.

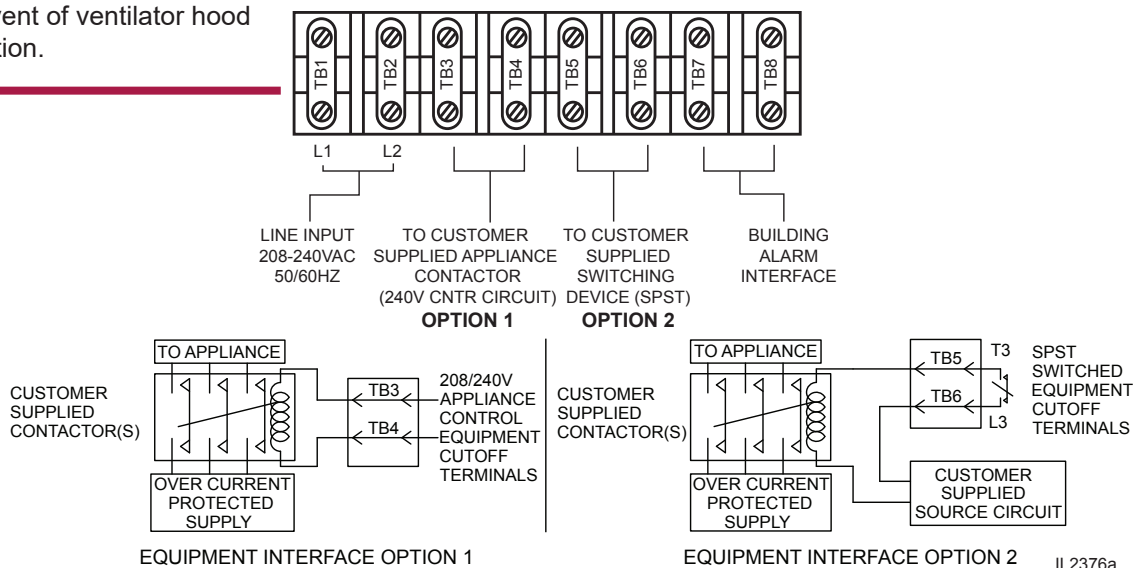

INSTALLATION continued

SUPPLY POWER INSTALLATION

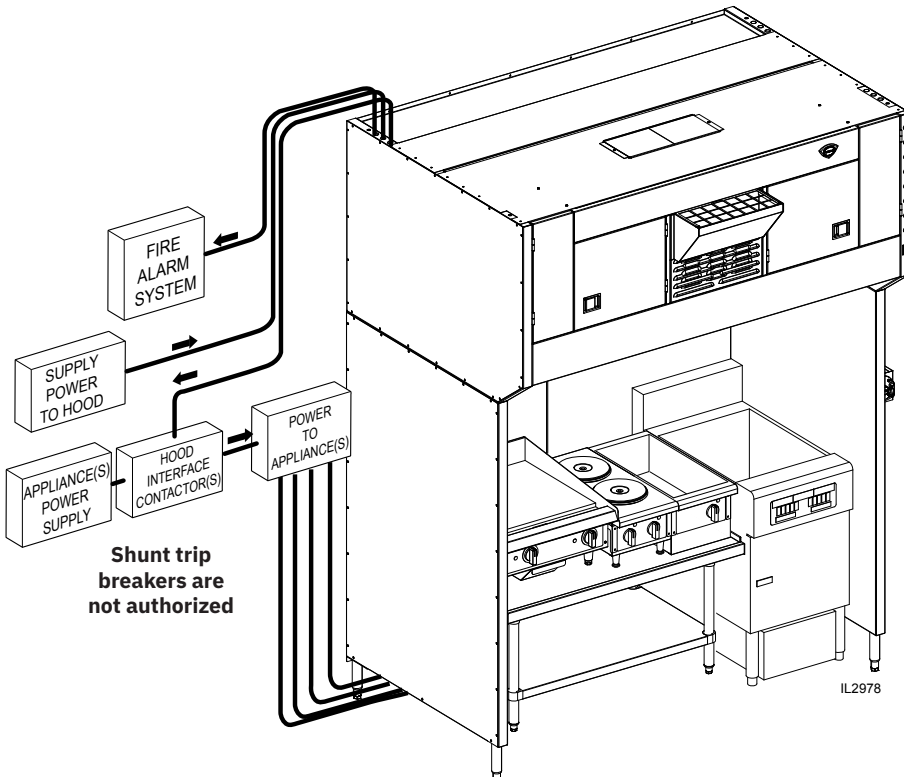

DANGER: SHOCK HAZARD

Turn power off to the unit before removing the side electrical box cover.



CAUTION: SHOCK HAZARD

The ground lug of this appliance must be connected to a suitable building ground.

IMPORTANT:
Contact a licensed electrician to install and connect electrical power to the appliance.

IMPORTANT:
Damage due to being connected to the wrong voltage or phase is NOT covered by warranty.

7/8" Electrical Knockouts 4 Top / 1 Back

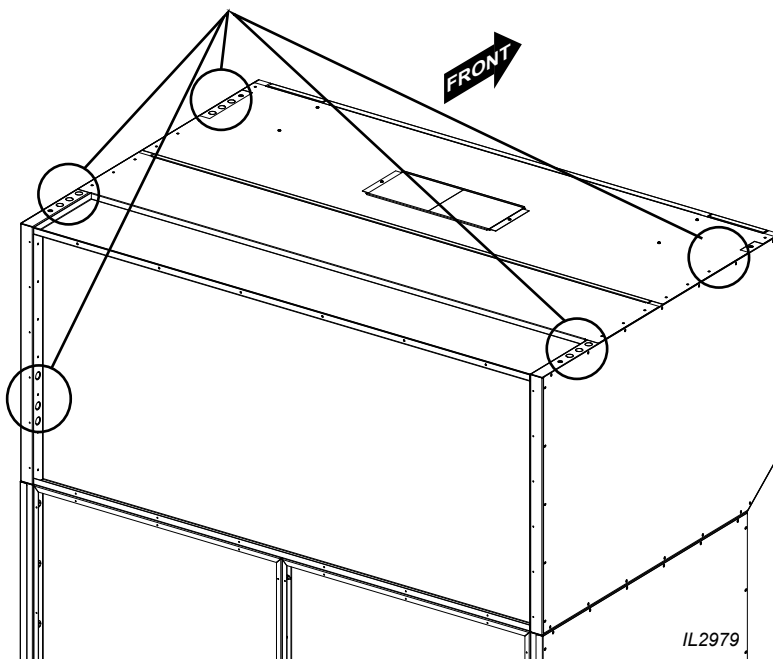

INSTALLATION continued



Fire suppression system must be charged and certified by an authorized Ansul® distributor.

DO NOT attempt to modify or bypass the fire suppression system.

An uncontrolled fire can cause serious injury or death.

NOTE:

If the fire suppression system is discharged, a buzzer will sound continuously. The unit will remain inoperable until the fire suppression system is serviced, recharged and reset by an authorized Ansul® distributor.

Charging of the Ansul® Fire Suppression system must be in accordance with Ansul® Design, Installation, Recharge and Maintenance Manual, #418087.

NOTE:

If a REMOTE MANUAL PULL STATION is installed, moving the ventilator for any reason may cause the Ansul® system to discharge.

IMPORTANT:

Should the fire suppression system discharge: all nozzles must be replaced, and all lines thoroughly cleaned, prior to recharging the system.

Residual fire suppression media may compromise the flow and dispersion of fire suppression media in any subsequent activation.

The alarm relay is activated by the Ansul® fire detection system. If the installation includes a building alarm system, connect to terminals T7 & T8 of the terminal block in supply connection box. These terminals are configured from the factory for normally open operation.

The ventilator will operate properly, and the appliance control relay will be energized, only when:

1. The VENTILATOR POWER SWITCH is "ON".
2. The Ansul® Fire Suppression System is charged and armed.
3. All filters are in position and serviceable, and the ventilator air flow system is satisfied.

FIRE SUPPRESSION SYSTEM INSTALLATION

The hood is supplied with a field installed MANUAL PULL STATION, which must be set-up at the time of installation by an authorized Ansul® distributor.

The MANUAL PULL STATION allows for manual emergency shutdown of cooking appliance power, and actuation of the fire suppression system.

Ten NOZZLES disperse the fire suppression media. Two inner nozzles protect the fan and plenum. The appliance nozzles are swivel mounted, and must be directed toward the cooking surface of the installed cooking appliance.

If the ventilator is situated such that the supplied manual pull station cannot be installed or is not readily accessible, a REMOTE MANUAL PULL STATION may be required by local codes. Any such remote manual pull station must be installed by an authorized Ansul® distributor in accordance with the AUTHORITY HAVING JURISDICTION.

The fire detection system utilizes five electronic thermal detectors with an actuation set point of 325°F (163°C). The signaling from any of these detection devices will automatically discharge the fire suppression media through all nozzles, disable the cooking appliances and cause the alarm to sound.

Fire suppression media will form an emulsion designed to both smother and cool the fuels in/on the cooking appliance.

INSTALLATION

FIRE SUPPRESSION SYSTEM INSTALLATION (continued)

The MANUAL PULL STATION and any similar REMOTE MANUAL PULL STATION will activate the fire suppression system when the ring on the pull station is pulled to its full extent.



DANGER
BURN HAZARD

Any additional remote pull station must **NOT** be installed on the front of the cooking appliances,

Discharge of the fire extinguishing system into hot grease or oil may cause hot foam to spill over from the cooking surface or frypot.

Serious burns and other injuries can result from contact with hot oil and from slipping in spilled oil.

The manual pull station is installed on the right side (facing the unit). It may, however, be relocated to the left side of the ventilator hood by an authorized Ansul® agent.

INSTALLATION

NOTE:

The BAFFLE FILTERS, PRE-FILTERS and FILTER PACK actuate position switches when they are properly positioned. They must be properly installed for the under hood cooking appliance contactor to be energized.



WARNING SLIP AND FALL HAZARD

DO NOT operate any grease-producing cooking appliance

(e.g. fryer or griddle) unless the grease cup is properly installed. Oil will drip onto floor creating a slipping hazard.



CAUTION BURN HAZARD

DO NOT operate any cooking appliance unless the grease cup is installed.

Moisture dripping onto hot surfaces, oil or grease can cause splattering.

NOTE: Adding moisture during the cooking process may cause the prefilter to lose structural integrity.

WARNING: Do not add moisture during cooking.

FILTER INSTALLATION

Note air flow direction arrow on filter pack. Remove old filter pack and slide new filter pack fully into the appropriate slot. Verify that the airflow arrow points toward the fan.

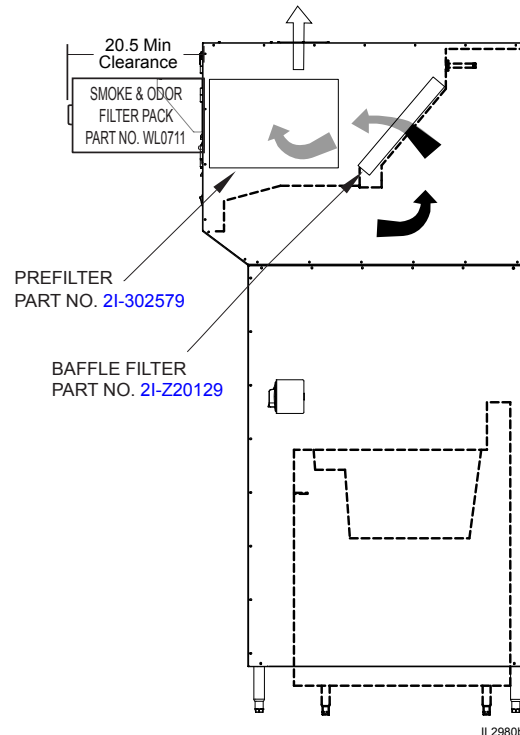

Baffle filters are reusable and should be cleaned at least weekly. Change pre-filters and smoke/odor filter pack as indicated on the front panel. These filters are disposable and cannot be reused. The smoke / odor filter pack is accessed thru the front service door.

Pre-filters are located behind the baffle filters, when installing pre-filters engage top retaining flange prior to seating pre-filter housing in lower chamber.

Use only genuine Wells replacement parts and filters, call (800) 264-7827 or your authorized Wells service agent. Parts supplied by others will void your warranty and may not provide safe operation.

BAFFLE FILTER and GREASE CUP INSTALLATION

1. Install baffle filter from front. Engage the baffle filter in the retainer slot. Push up until the baffle filter bottom clears the lower lip of the retainer, then lower the baffle filter into the bottom retainer
2. Install GREASE CUP into brackets below the baffle filter.

Note: Failure to install the GREASE CUP will allow grease and moisture from the BAFFLE FILTER to drop into hot cooking surfaces, creating both a SAFETY HAZARD (hot oil splatter) and a HEALTH HAZARD (contamination of the cooking surface or cooking oil).

OPERATION

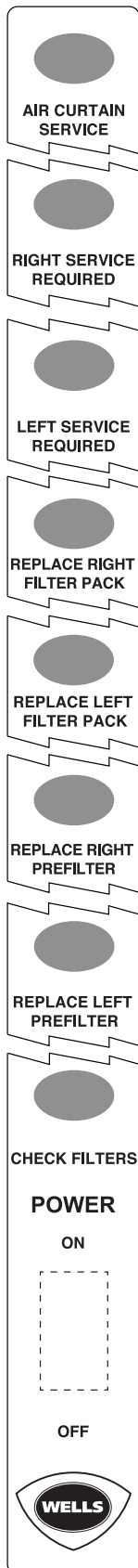

Control Panel

NOTE: Cooking appliances must be operated in accordance with the manufacturer's instructions.

During normal operation, the illuminated power switch will be the only light on the control panel that will be ON.

If the CHECK FILTERS light illuminates, check BAFFLE FILTERS, PREFILTERS, and the HEPA AIR FILTERS for proper installation.

If the REPLACE PRE-FILTERS light illuminates. Replace the Pre-filters.

If the REPLACE FILTER light illuminates, replace the FILTER PACK.

NOTE: the REPLACE FILTERS light is a warning that filter pack is nearing the end of its service life. The ventilator will continue to operate for a period of time after the REPLACE FILTER LIGHT turns ON to allow continued operation through a peak period. However, filter pack must be replaced within a short time period or it will clog, disabling the ventilator and appliances.

If the SERVICE REQUIRED light illuminates, the filter pack is restricted to the point of insufficient airflow for proper operation and the cooking equipment will shut down until the underlying clogged filter situation has been corrected. Replace clogged item with a fresh filter to correct the condition. Reset the unit by turning VENTILATOR POWER SWITCH to OFF, then back to ON.

If the air curtain service required lights illuminate, there is insufficient airflow for proper operation. Call an authorized Wells Service Agent.

A failure of incoming electric power will cause a shut down of the unit. Reset the unit by turning VENTILATOR POWER SWITCH to OFF, then back to ON.

Operation Lights

There are four (4) equipment lights that provide illumination of the working area. These lights are controlled by the main power switch.



CAUTION: HOT SURFACE

Exposed surfaces can be hot to the touch and may cause burns.



CAUTION: SHOCK HAZARD

DO NOT splash or pour water or grease onto control panel or wiring.

IMPORTANT:

The ventilator cannot operate if the filter pack is removed or clogged.

It is the responsibility of the store management to maintain sufficient spares of filter packs to avoid prolonged shutdown of the ventilator when this filter is expended.

Filter packs cannot be cleaned.

Wells Manufacturing assumes no liability for loss of business due to filter related shutdown.

Filters that are not genuine Wells Replacement Parts may cause your unit to operate incorrectly and you will risk the possibility of voiding your warranty.

CLEANING INSTRUCTIONS



CAUTION: HOT SURFACE

Exposed surfaces can be hot to the touch and may cause burns. Allow unit to cool before cleaning.

PRECAUTIONS: Disconnect unit from electric power and allow to cool
Cover frypot to prevent oil contamination

FREQUENCY: Daily

TOOLS: Mild detergent, clean non-abrasive towels, 3M Scotch brite for griddles



CAUTION: SHOCK HAZARD

DO NOT splash or pour water or grease onto control panel or wiring.

NOTE: Ventilator section to be cleaned in conjunction with cooking appliance. Refer to appliance user instructions for cleaning procedure.

DO NOT clean heated surfaces with water and/or ice or Ansul. System may activate due to sudden rise in temperature change, causing the fire suppression system to deploy.

1. TURN HOOD POWER SWITCH TO OFF.
Cover cooking appliance to prevent oil contamination.
2. Remove GREASE TROUGH, BAFFLE FILTERS and GREASE CUP.
3. Empty GREASE CUP into an appropriate grease collection receptacle.
4. Wipe GREASE TROUGH clean
5. Clean BAFFLE FILTERS and GREASE CUP in a sink or dishwasher using mild detergent and warm water.
6. Dry components with a clean non-abrasive cloth. Reinstall GREASE TROUGH, BAFFLE FILTERS and GREASE CUP in ventilator.
7. Wipe exterior of ventilator with a clean cloth moistened with warm water and mild detergent. Rinse by wiping with a clean cloth moistened with warm water.
8. Uncover the cooking appliance and reconnect unit to electric power.

Procedure is complete

CLEANING INSTRUCTIONS

PRECAUTIONS: Disconnect unit from electric power and allow to cool
Cover cooking surfaces and frypots to prevent contamination.

FREQUENCY: Monthly

TOOLS: Mild detergent, clean non-abrasive towels, 3M Scotch brite for griddles

NOTE: Ventilator section to be cleaned in conjunction with cooking appliance. Refer to appliance user instructions for cleaning procedure.



CAUTION: HOT SURFACE

Exposed surfaces can be hot to the touch and may cause burns. Allow unit to cool before cleaning.



CAUTION: SHOCK HAZARD

DO NOT splash or pour water or grease onto control panel or wiring.

1. TURN HOOD POWER SWITCH TO OFF.
Cover cooking appliance to prevent oil contamination.
2. Remove GREASE TROUGH, BAFFLE FILTERS, GREASE CUP, and all FILTER PACK(s).
3. Wipe interior of ventilator with a clean cloth moistened with warm water and mild detergent. Rinse by wiping with a clean cloth moistened with warm water. **DO NOT** clean by spraying.
4. Dry ventilator thoroughly with a clean non-abrasive cloth.
Reinstall the GREASE TROUGH, FILTERS, BAFFLE FILTERS, and GREASE CUP.
5. Uncover the cooking appliance and reconnect unit to electric power.

Procedure is complete

IMPORTANT:

DO NOT wash FILTER PACK. Washing these filters will clog them, and cause installed cooking appliance to be disabled.

IMPORTANT:

DO NOT clean interior of ventilator by spraying.

Spraying can contaminate the cooking appliance, and may cause internal damage to the ventilator blower, operation proofing system and/or fire suppression system.

Clean by wiping only.

DO NOT clean heated surfaces with water and/or ice or Ansul. System may activate due to sudden rise in temperature change, causing the fire suppression system to deploy.

REQUIRED MAINTENANCE

IMPORTANT:

Per NFPS 96, a signed and dated VENTILATOR HOOD MAINTENANCE LOG must be maintained on the premises, and be made available for inspection by the authority having jurisdiction upon request.

IMPORTANT:

Should the fire suppression system discharge, all lines and nozzles must be thoroughly cleaned prior to recharging the system.

Ansul deployments are not covered under warranty.

Technical Service needs to be contacted immediately and a deployment kit of parts needs to be replaced before the unit is back in service.

Be sure to note such cleaning on the hood maintenance log. Residual fire suppression media may compromise the flow and dispersion of fire suppression media in any subsequent activation.

USE AND MAINTENANCE SHALL BE IN ACCORDANCE WITH THE STANDARD FOR VENTILATION CONTROL AND FIRE PROTECTION OF COMMERCIAL COOKING OPERATIONS, N.F.P.A. 96 (current edition).

3-MONTH MAINTENANCE:

Thoroughly clean entire HOOD PLENUM and BLOWER section.

6-MONTH MAINTENANCE:

Inspection and testing of total operation including FIRE DAMPER and all SAFETY INTERLOCKS shall be performed by qualified service personnel.

All FIRE SUPPRESSION SYSTEM actuation components including MANUAL PULL STATION and any REMOTE MANUAL PULL STATION must be inspected for proper operation in accordance with the maintenance schedule published in ANSUL® R-102 SYSTEM DESIGN, INSTALLATION, RECHARGE AND MAINTENANCE MANUAL (418087).

ANNUAL (12-MONTH) MAINTENANCE:

NOZZLES and MANUAL PULL STATION must be cleaned in accordance with ANSUL® R-102 SYSTEM DESIGN, INSTALLATION, RECHARGE AND MAINTENANCE MANUAL (418087).

12-YEAR MAINTENANCE:

The FIRE SUPPRESSION AGENT TANK must be HYDROSTATICALLY TESTED, and the FIRE EXTINGUISHING AGENT must be REPLACED in accordance with the maintenance schedule published in ANSUL® R-102 SYSTEM (STANDARD UL 300 LISTED). This maintenance to be performed by qualified Ansul® service personnel only.

NOTES

Inspection shall be conducted on a monthly basis in accordance with the manufacturer's Operation Manual. At a minimum, this inspection shall include verification of the following:

WELLS BLOOMFIELD, LLC
VENTILATOR HOOD OWNERS MONTHLY INSPECTION LOG

OPERATION	AGENT DATE												
Extinguishing system components: In proper place and (visually in good order													
Manual pull station actuators for fire suppression system are obstructed													
The maintenance log is in place and up to date													
No obvious physical damage or condition exists that might prevent operation of the fire suppression system													
The nozzle blow-off caps are in place and in good condition													
The hood, duct and protection cooking appliance have not been replaced, modified or relocated													
Clean plenum GREASE BAFFLE and BLOWER (max. interval: 3 months)													
Change PRE-FILTER and FILTER PACK (as required)													

IL2144

This MAINTENANCE LOG is to be performed and completed by a trained technician who has completed the instruction necessary to perform the maintenance and recharge service.

WELLS BLOOMFIELD, LLC
VENTILATOR HOOD MAINTENANCE LOG

OPERATION	AGENT / DATE												
Clean and inspect discharge nozzle in plenum BEFORE filters MAX. interval: 6 months													
Clean and inspect discharge nozzle in plenum AFTER filters MAX. interval: 6 months													
Inspect fire suppression detectors, all releasing devices for actuation, fire suppressant tank liquid level Max interval: 6 months (discharge of fire suppressant not a part of this test)													
Inspect fire suppression hoses, plumbing and tank for obstructions and any condition such as, but not limited to, corrosion and pitting. Max interval: 6 months													
Inspect and test all filter interlocks Max. interval: 6 months													
Replace fire damper fusible link: rated @ 212°F Max interval: 12 months													
	Log TEMP												
	Log mfg DATE Stamp												

IL2378a

THIS MAINTENANCE LOG MUST BE KEPT IN A PROTECTIVE COVER PERMANENTLY ATTACHED TO THE APPLIANCE
Log all repairs and recommendations on reverse side. Any repairs, other than replacement of factory authorized parts, to the fire suppression plumbing system must be subject to hydrostatic pressure testing.

ANSULEX Low pH

QUICK IDENTIFIER (In Plant Common Name)

Manufacturer's Name:	ANSUL INCORPORATED	Emergency Telephone No.:	CHEMTREC (800) 424-9300 or (703) 527-3887
Address:	One Stanton Street, Marinette, WI 54143-2542	Other Information Calls:	(715) 735-7411
Prepared By:	Safety and Health Department	Date Prepared:	February 1, 1999

SECTION 1 - IDENTITY

Common Name (Used on Label): (Trade Name and Synonyms)	ANSULEX Low pH Liquid Fire Suppressant	CAS No.:	N/A
Chemical Name:	N/A This is a Mixture	Chemical Family:	Mixture
Formula:	N/A		

SECTION 2 - INGREDIENTS

PART A - HAZARDOUS INGREDIENTS				
Principal Hazardous Component(s) (chemical and common name(s)):	Wt. %	CAS No.	ACGIH TLV	Acute Toxicity Data
None	N/A	N/A	N/A	N/A
PART B - OTHER INGREDIENTS				
Other Component(s) (chemical and common name(s)):	Wt. %	CAS No.	ACGIH TLV	Acute Toxicity Data
Proprietary Mixture of Organic and Inorganic Salts	48.0 - 50.0	N/A	N/E	NDA
Phosphoric Acid	0.2	7664-38-2	N/E	NDA
EDTA	0.65	64--02-8	N/E	NDA
Yellow-Green Fluorescent Dye	0.011	518-47-8	N/E	Oral LD ₅₀ (rat) 6800 mg/kg
Water	Approx. 50.0	7732-18-5	N/E	NDA

SECTION 3 - PHYSICAL AND CHEMICAL CHARACTERISTICS (Fire and Explosion Data)

Boiling Point:	113°C	Specific Gravity (H ₂ O=1):	1.33	Vapor Pressure (mm Hg):	Not Determined
Percent Volatile by Volume (%):	Approx. 50.0	Vapor Density: (Air = 1):	1.03	Evaporation Rate: (Butyl Acetate=1):	Approx. 0.005
Solubility in Water:	100%	Reactivity in Water:	Mild exothermic reaction		
Appearance and Odor:	Fluorescent Yellow Colored Liquid, Mild Odor				
Flash Point:	None to boiling	Flammable Limits in Air % by Volume:	N/A	Extinguisher Media:	N/A
Auto-Ignition Temperature:	N/A				
Special Fire Fighting Procedures:	NONE - THIS IS AN EXTINGUISHING AGENT				
Unusual Fire and Explosion Hazards:	None				

SECTION 4 - PHYSICAL HAZARDS

Stability:	Unstable <input type="checkbox"/> Stable <input checked="" type="checkbox"/>	Conditions to Avoid:	N/A
Incompatibility (Materials to Avoid):	Reactive Metals, ClF ₃ , electrically energized equipment, any material reactive with water.		
Hazardous Decomposition Products:	Not established, acrid fumes.		
Hazardous Polymerization:	May Occur <input type="checkbox"/> Will Not Occur <input checked="" type="checkbox"/>	Conditions to Avoid:	N/A

M522 p/n 2M-Z16247 OpM WVU- Universal Hood

SECTION 5 - HEALTH HAZARDS

ANSULEX Low pH (continued)

Threshold Limit Value:	None Established		
Routes of Entry: Eye Contact:	Irritant		
Skin Contact:	Irritant		
Inhalation:	Not an expected route of entry. Can be irritating to mucous membranes.		
Ingestion:	Irritating to mucous membranes. Acute Oral LD ₅₀ (Sprague-Dawley rats) 825.5mg/kg.		
Signs and Symptoms:	Acute Exposure: Material irritates skin, eyes, and mucous membranes. Chronic Exposure: None known.		
Medical Conditions Generally Aggravated by Exposure:	None known.		
Chemical Listed as Carcinogen or Potential:	National Toxicology Program: Yes <input type="checkbox"/> No <input checked="" type="checkbox"/>	I.A.R.C Monographs: Yes <input type="checkbox"/> No <input checked="" type="checkbox"/>	OSHA Yes <input type="checkbox"/> No <input checked="" type="checkbox"/>

SECTION 6 - EMERGENCY AND FIRST AID PROCEDURES

Eye Contact:	Flush and irrigate with water for 15 minutes while holding eyelids open. If irritation persists, seek medical attention.
Skin Contact:	Wash thoroughly with soap and water. If irritation persists, seek medical attention.
Inhalation:	Fresh air if symptoms occur. If irritation persists, seek medical attention.
Ingestion:	Dilute by drinking large quantities of water.

SECTION 7 - SPECIAL PROTECTION INFORMATION

Respiratory Protection (Specify Type):	N/A		
Ventilation:	Local Exhaust: N/A	Mechanical (General):	N/A
Protective Gloves:	Rubber gloves for spill/leak	Eye Protection:	Chemical goggles recommended during spill/leak procedures.
Other Protective Clothing or Equipment:	Eye wash and safety showers are good safety practice.		

SECTION 8 - SPECIAL PRECAUTIONS AND SPILL/LEAK PROCEDURES

Precautions to be taken in Handling and Storage:	Store in original container. Keep tightly closed. Keep separate from acid.
Other Precautions:	See incompatibility information in Section 4.
Steps to be taken in Case Material is Released or Spilled:	Stop leaks. Contain spills. Remove as much as possible. Place in closed container for proper disposal Wash spill area with large amounts of water to remove traces and neutralize.
Waste Disposal Methods:	Dispose of in compliance with local, state and federal regulations.

HAZARDOUS MATERIAL IDENTIFICATION SYSTEM

HAZARD INDEX	
4 SEVERE HAZARD	0 HEALTH
3 SERIOUS HAZARD	0 FLAMMABILITY
2 MODERATE HAZARD	0 REACTIVITY
1 SLIGHT HAZARD	
0 MINIMAL HAZARD	

N/A = Not Applicable NDA = No Data Available N/E = Not Established

ANSUL and ANSULEX are registered trademarks.

Internet Address: <http://www.ansul.com>

ANSUL INCORPORATED, ONE STANTON STREET, MARINETTE, WI 54143-2542

Form No. F-90160-6

©1999 Ansul Incorporated

M522 p/n 2M-Z16247 Opm WVU- Universal Hood

TROUBLESHOOTING SUGGESTIONS

Problem	Possible Cause	Suggested Remedy
Unit will not operate (no indicators lights lit)	Disconnected from electric power	Reconnect to electric power
		Reset circuit breaker for unit
Unit will not operate (buzzer sounds)	Fire suppression system not set	Contact an authorized Ansul® distributor for repairs
CHECK FILTER light lit	Filter pack, Pre-filter or baffle filter not in position	Properly install filters
REPLACE FILTER light lit	Filter nearing end of service life	Arrange to replace filters in a timely manner
	Filter pack plugged	Replace filter pack
	Fire damper in exhaust collar has closed	Contact an authorized Wells service agent for repairs
SERVICE REQUIRED light lit (cooking appliance not operating)	One or more vacuum sensing lines or ports plugged, or sensing line dislodged.	Contact an authorized Wells service agent for repairs
	NOTE: If, after 20 seconds, there is insufficient airflow for proper operation, SERVICE REQUIRED light will illuminate and under-hood appliance (s) will be de-energized.	
	Press VENTILATOR POWER SWITCH to OFF, then back to ON to reset system.	

NOTE:

FILTERS are the only user serviceable components in this ventilator hood system. For all problems that cannot be remedied by servicing the filters, contact:

- Ventilator section - authorized Wells service agency
- Fire suppression system - authorized Ansul® distributor

IMPORTANT:

Contact ANSUL® for fire suppression system installation, set-up and service:

Ansul Incorporated 1-800-TO-ANSUL (1-800-862-6785)
 One Station Street
 Marinette, WI 54143-2542 website <http://www.ansul.com>

IMPORTANT:

Parts used in the Ansul® fire suppression system are not serviceable by the owner/operator.

Procedures for servicing fire suppression equipment are described in:

ANSUL® R-102 SYSTEM DESIGN, INSTALLATION, RECHARGE AND MAINTENANCE MANUAL
 (418087, current edition)

NOTE:

ANSUL® Manual 418087 is intended for use by authorized Ansul® service personnel only.

EXPLODED VIEW & PARTS LIST

Filter Maintenance

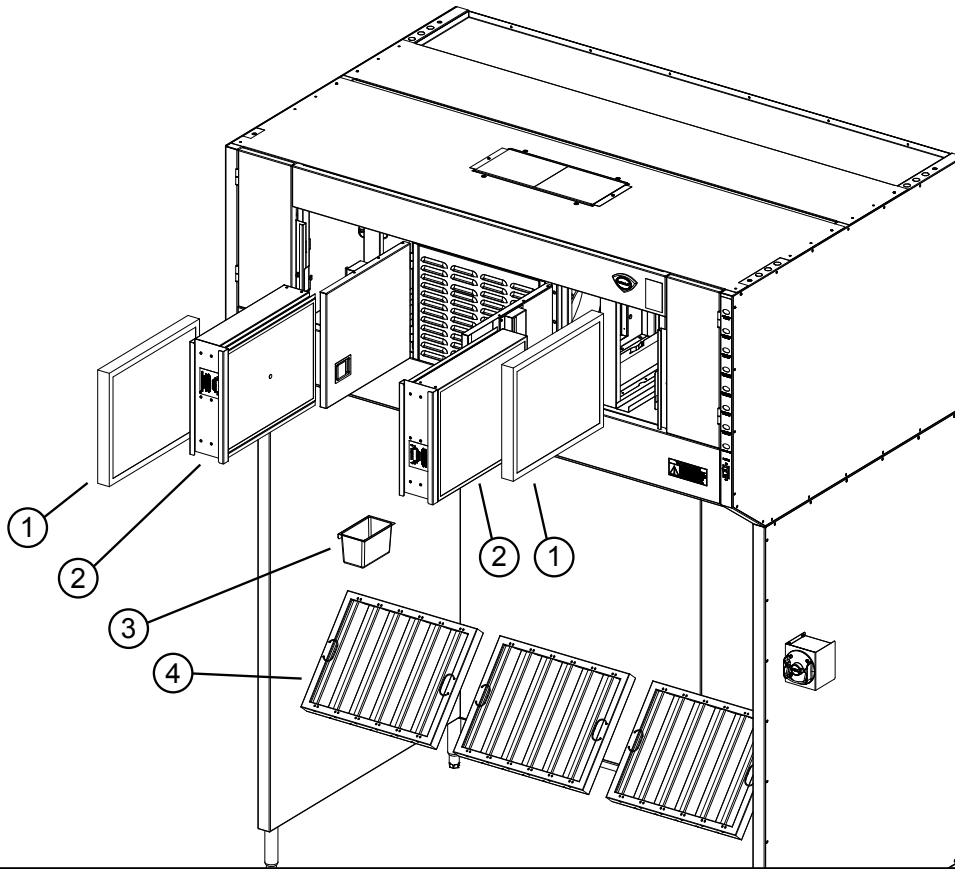

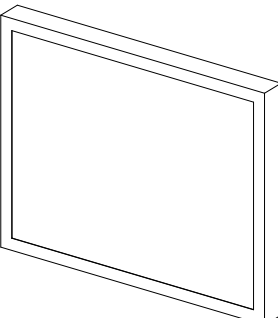
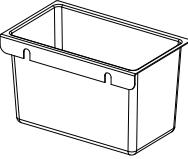
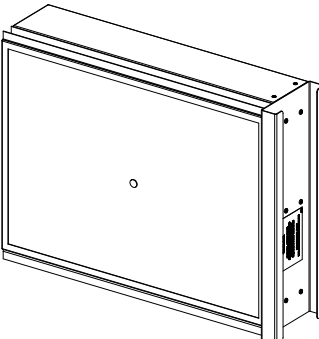
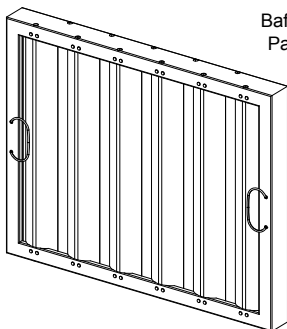
<p>①</p>  <p>Pre-Filter Hood Part No: 2I-302579</p>	<p>③</p>  <p>Grease Cup Part No: 2D-Z20435</p>
<p>②</p>  <p>Filter HEPA/Carbon Pack Part No: N1-WL0711</p>	<p>④</p>  <p>Baffle Filter 16" x 20" Part No: 2I-Z20129</p>

Model: WVU72 Filter Assembly

SK2939, Rev -, 12/22/15

M527 p/n 2M-Z19046 OpM WVU- Universal Hood

EXPLODED VIEW & PARTS LIST

Universal Hood Internal Controls

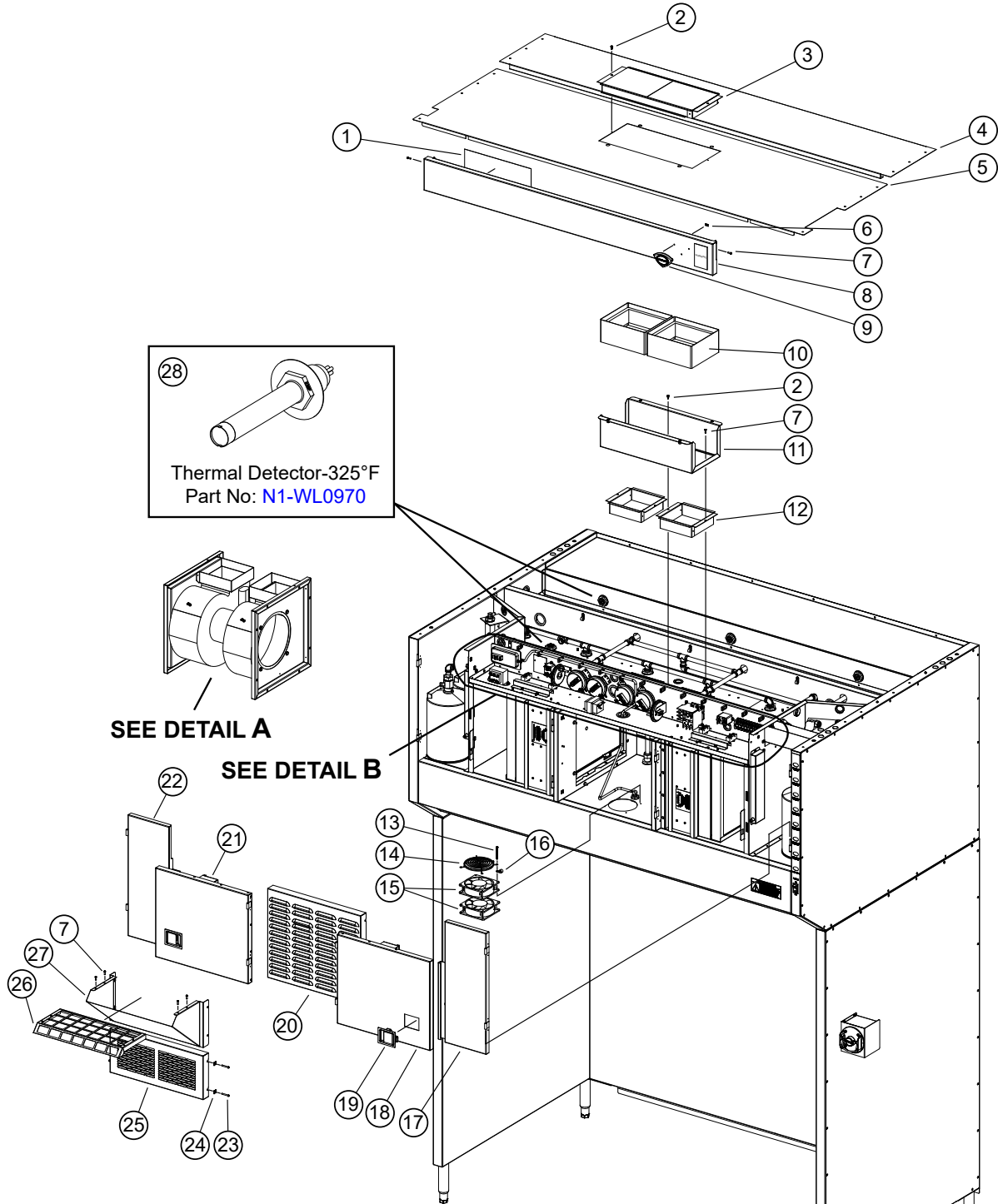

28
 Thermal Detector-325°F
 Part No: [N1-WL0970](#)

SEE DETAIL A

SEE DETAIL B

M527 p/n 2M-Z19046 OpM WVU- Universal Hood

WVU72: Universal Hood Internal Control



SK2940 REV A(07-22)

PARTS LIST

Universal Hood Internal Control

Model WVU-72: Universal Hood Internal Controls			
Fig No.	Part Number	Quantity	Description
1	2M-Z19055	1	LABEL, WIRE DIAGRAM
2	2C-301522	53	SCREW 8X1/2 PH PAN DRIL S
3	N1-WL0725	1	DAMPER SCREEN ASSY
4	N1-Z18984	1	PANEL, TOP COVER, REAR
5	N1-Z18978	1	PANEL, TOP COVER, FRONT
6	2C-31038	3	RETAINER CLIP TINNERMAN B
7	2C-1494	73	SCREW 8-32X1/2 RHP STL NP
8	N1-Z18991	1	PANEL, FRONT, ELECTRONICS
9	2M-306719	1	LOGO WELLS DIECAST SHIELD
10	2V-307913	2	DAMPER FIRE 8x9 WVU 212'F
11	N1-Z19770	1	DAMPER CAGE, VERT DISCHARG
12	N1-WL0641	2	VERTICAL DISCHARGE COLLAR
13	2C-Z23124	4	SCREW 8-32X3.5 PH PAN HD MS
14	2R-Z20191	1	WIRE GUARD 120MM
15	2U-Z17520	2	MUFFIN FAN 130CFM
16	2C-Z18059	4	CABLE CLAMP NYLON 1/2 DIA
17	N1-WL0635	1	ANSUL DOOR ASSY, RIGHT
18	N1-WL0632	1	FILTER DOOR ASSY, RIGHT
19	2R-Z17654	2	LATCH, DOOR
20	N1-Z19772	1	PANEL, FRONT VERT DISCHARG
21	N1-WL0631	1	FILTER DOOR ASSY, LEFT
22	N1-WL0636	1	ANSUL DOOR ASSY, LEFT
23	2C-H1559	4	SCREW 8-32X1 1/4 RHP STL
24	2C-70132	12	NUT TNR ZI #8
25	N1-Z18995	1	FRONT DISCHARGE VENT
26	N1-Z19846	OPTIONAL	SCREEN ASY, HORIZ DISCHARGE
27	N1-Z19842	OPTIONAL	DIVERTER ASSEMBLY
28	N1-WL0970	5	THERMAL DETECTOR-325F

January 5, 2016

EXPLODED VIEW

Universal Hood Blower Assembly

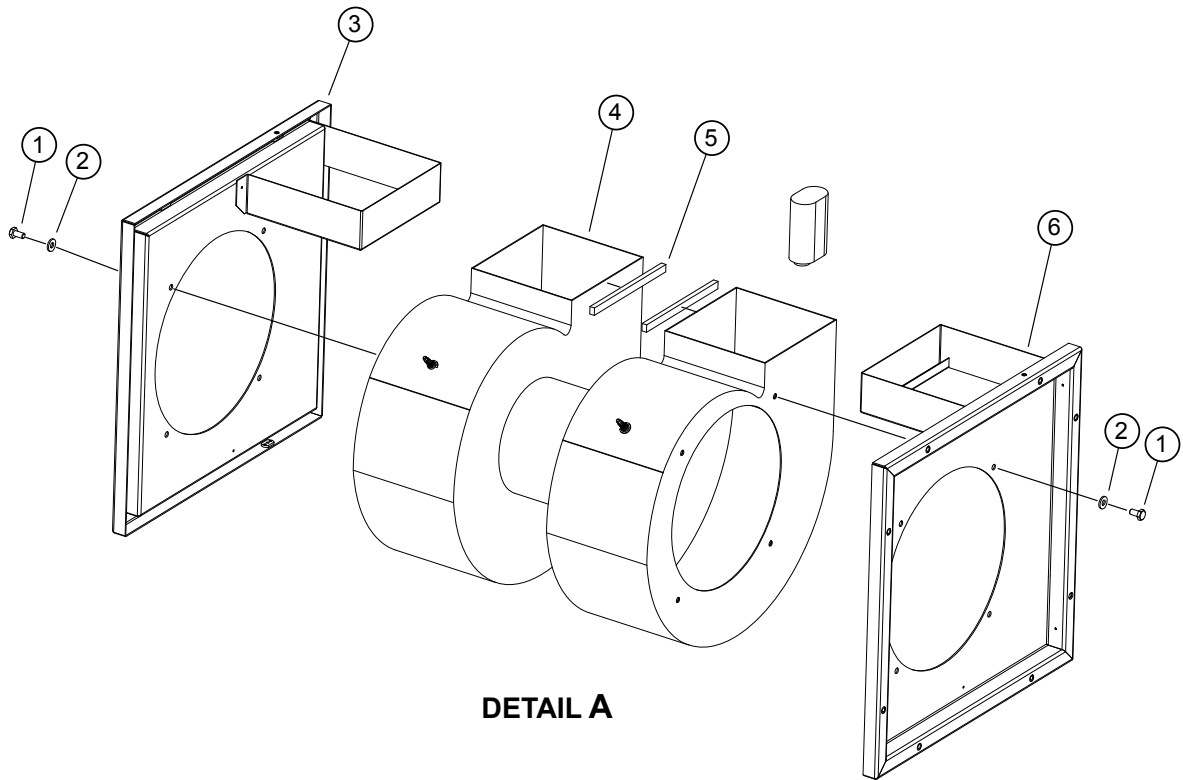

Model WVU-72: Universal Hood Detail A

Fig No.	Part Number	Quantity	Description
1	2C-Y1221	8	BOLT 1/4-20X1/2 HEX STL
2	2C-1811	8	WASHER 1/4 BURR STL NP
3	N1-WL0674	1	BLOWER SUPPORT ASY, LEFT
4	2U-Z19006	1	BLOWER, DUAL CAGE
5	1P-302749	SOLD BY FOOT	TAPE SILICONE GRAY VCS 3/
6	N1-WL0675	1	BLOWER SUPPORT ASY, RIGHT

WVU72: Blower Assembly



SK2942 Rev. - 12/28/2015

PARTS LIST

Universal Hood Internal Controls: Detail B

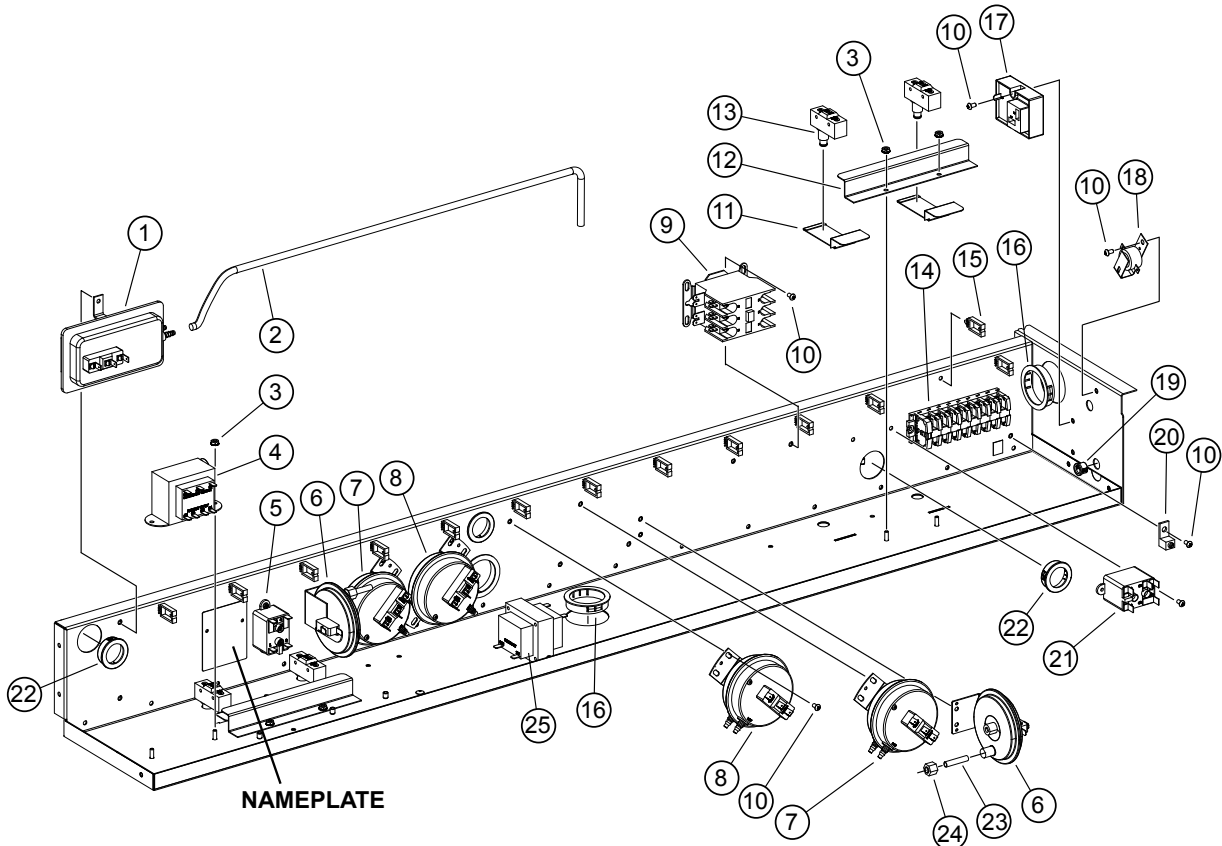

DETAIL B

WVU72: Internal Control Assembly



SK2943 Rev. - 12/28/2015

EXPLODED VIEW: DETAIL B

Universal Hood Internal Controls: Detail B

Model WVU-72: Internal Controls Assy, Detail B			
Fig No.	Part Number	Quantity	Description
1	2E-Z14673	1	PRESSURE SWITCH
2	2J-302629	sold by foot	HOSE, .18" ID- .31OD
3	2C-Z7165	4	NUT 8-32 HEX SS W/EXT WSH
4	2E-Z15335	1	TRANSFORMER, 208/240
5	2E-Z15353	1	RELAY, 120V COIL, SPNO
6	2E-Z21019	2	SWITCH VACUUM #2
7	2E-Z21020	2	VACUUM SWITCH,HEPA FILTER
8	2E-Z15365	2	PRESSURE SWITCH
9	2E-Z14960	1	CONTACTOR, 40A
10	2C-31715	120	SCREW 8-32X5/16 PH RD HD
11	N1-Z18063	4	PLATE, INTERLOC
12	N1-Z19947	2	RETENSION PLATE
13	2E-Z12427	9	SWITCH, SPDT (DOOR)
14	N1-WL1059	1	TERMINAL BLOCK ASSY 8 POLE
15	2C-Z19786	16	WIRE SADDLE 1.0 X 0.6
16	2K-Y8571	9	BUSHING SNAP 2 1/8
17	2P-Z17415	1	TIMER,CUBE/ RELAY
18	2J-44834	1	BUZZER 220V ROHS
19	2K-Y1139	2	BUSHING HEYCO SB500-6
20	2C-307288	1	LUG GROUND SOLDERLESS 2-1
21	2E-44514	1	RELAY 208-240V COIL
22	2K-70801-02	6	SNAP BUSH 1 3/8 SB1375-16
23	N1-301433	2	TUBING ALUM 1/4 X 1 1/4
24	2C-307597	2	NUT COMPRESSION 7/16-24 B
25	2E-Z15018	1	TRANSFORMER, 208/240 12V
26	2C-301522	4	SCREW 8X1/2 PH PAN DRILL

M527 p/n 2M-Z19046 OpM WVU- Universal Hood

January 5, 2016

EXPLODED VIEW & PARTS LIST

Universal Hood Suppression System

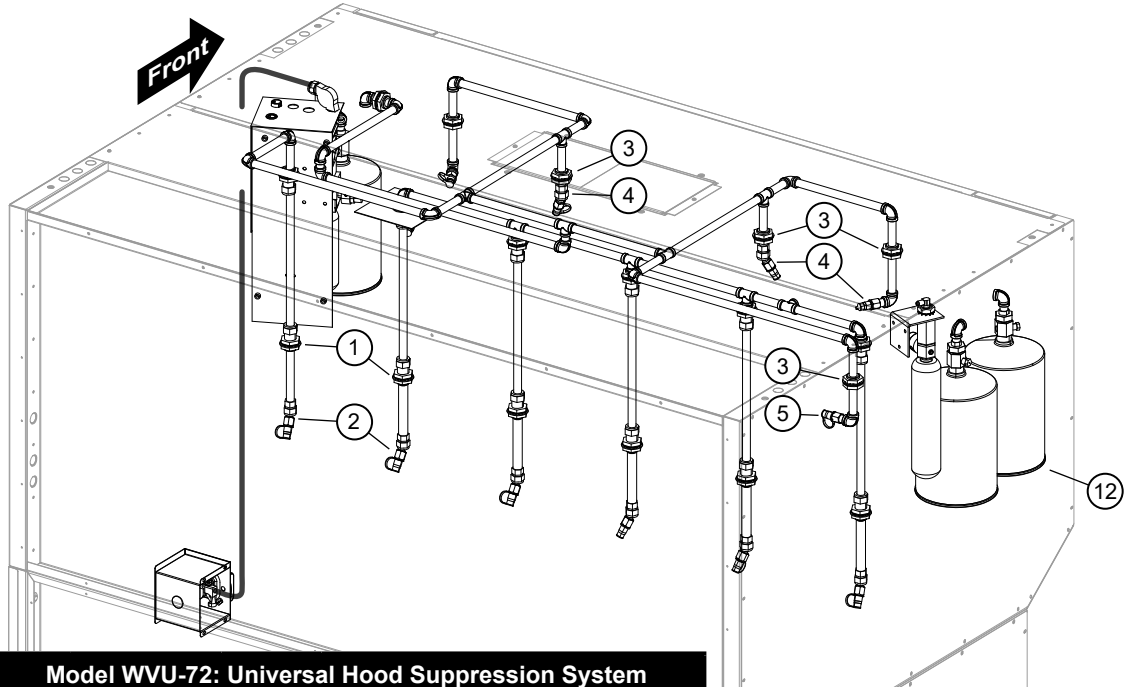

Model WVU-72: Universal Hood Suppression System

Fig No.	Part Number	Quantity	Description
1	2K-301245	12	COMPRESSION SEAL 1/2 EMT
2	2O-Z17942	6	SUPPRESSION NOZZLE 230
3	2K-47269	19	ADAPTER 3/8IN QUICK CON A
4	2O-Z20376	4	NOZZLE, # 1/2 N
5	2O-47267	1	NOZZLE ANSUL 1N
6	2K-Z15635	2	ELBOW,MALE 7/16-20x1/4NPT
7	2O-307966	1	ANSUL REG. ACTUATOR ASSY
8	2O-Z14918	1	ANSUL CARTRIDGE LT-30-R
9	N1-Z15435	1	ELEC. AUTOMAN BKT. MODIFY
10	2O-47099	1	ANSUL CARTRIDGE LT-20-R
11	2O-308131	1	REMOTE PULL STATION RED
12	2O-304433	3	TANK SS ANSULEX 1.5 GALLO

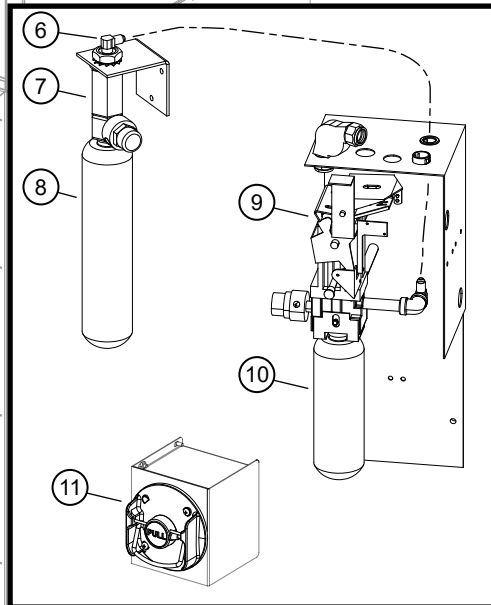

Ansul Deployments are not covered under warranty. Technical service (800)-264-7827 needs to be contacted immediately and a deployment kit of parts needs to be replaced before unit is put back in service.

WS-WL0965	DEPLYMNT KIT, WVY-72	QTY
2E-305295	SWITCH ROCKER 250V 10A GR	1
N1-WL0630	BLOWER ASSEMBLY	1
2U-Z17520	MUFFIN FAN, 130CFM 208/240	2
2E-200387	CORD FAN PLUG	2
N1-WL0711	HEPA/CARB FLTR PACK WVU72	2
2I-302579	FILTER PRE HOOD UNIVERSAL	2
2E-Z12427	SWITCH, SPDT (DOOR)	9



SK2941 REV A (07-22)

EXPLODED VIEW & PARTS LIST

Universal Hood Internal Control (Detail b)

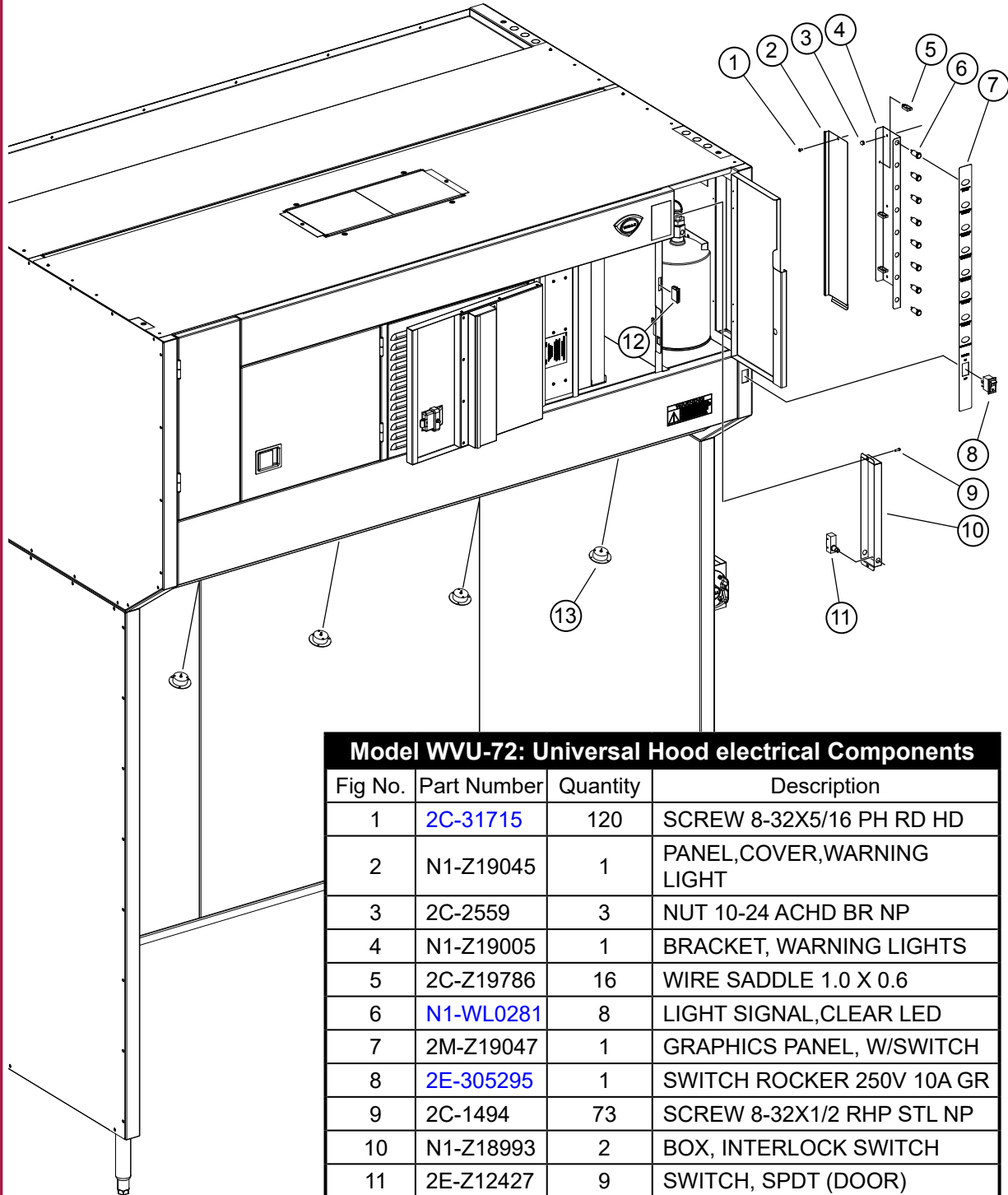

Model WVU-72: Universal Hood electrical Components

Fig No.	Part Number	Quantity	Description
1	2C-31715	120	SCREW 8-32X5/16 PH RD HD
2	N1-Z19045	1	PANEL,COVER,WARNING LIGHT
3	2C-2559	3	NUT 10-24 ACHD BR NP
4	N1-Z19005	1	BRACKET, WARNING LIGHTS
5	2C-Z19786	16	WIRE SADDLE 1.0 X 0.6
6	N1-WL0281	8	LIGHT SIGNAL,CLEAR LED
7	2M-Z19047	1	GRAPHICS PANEL, W/SWITCH
8	2E-305295	1	SWITCH ROCKER 250V 10A GR
9	2C-1494	73	SCREW 8-32X1/2 RHP STL NP
10	N1-Z18993	2	BOX, INTERLOCK SWITCH
11	2E-Z12427	9	SWITCH, SPDT (DOOR)
13	2E-WL0245	4	LED FLOODLIGHT, 45W CW

M527 p/n 2M-Z19046 OpM WVU- Universal Hood

WVU72: Electrical Components



SK2944 Rev. - 12/29/2015

EXPLODED VIEW & PARTS LIST

Universal Hood Base Assy

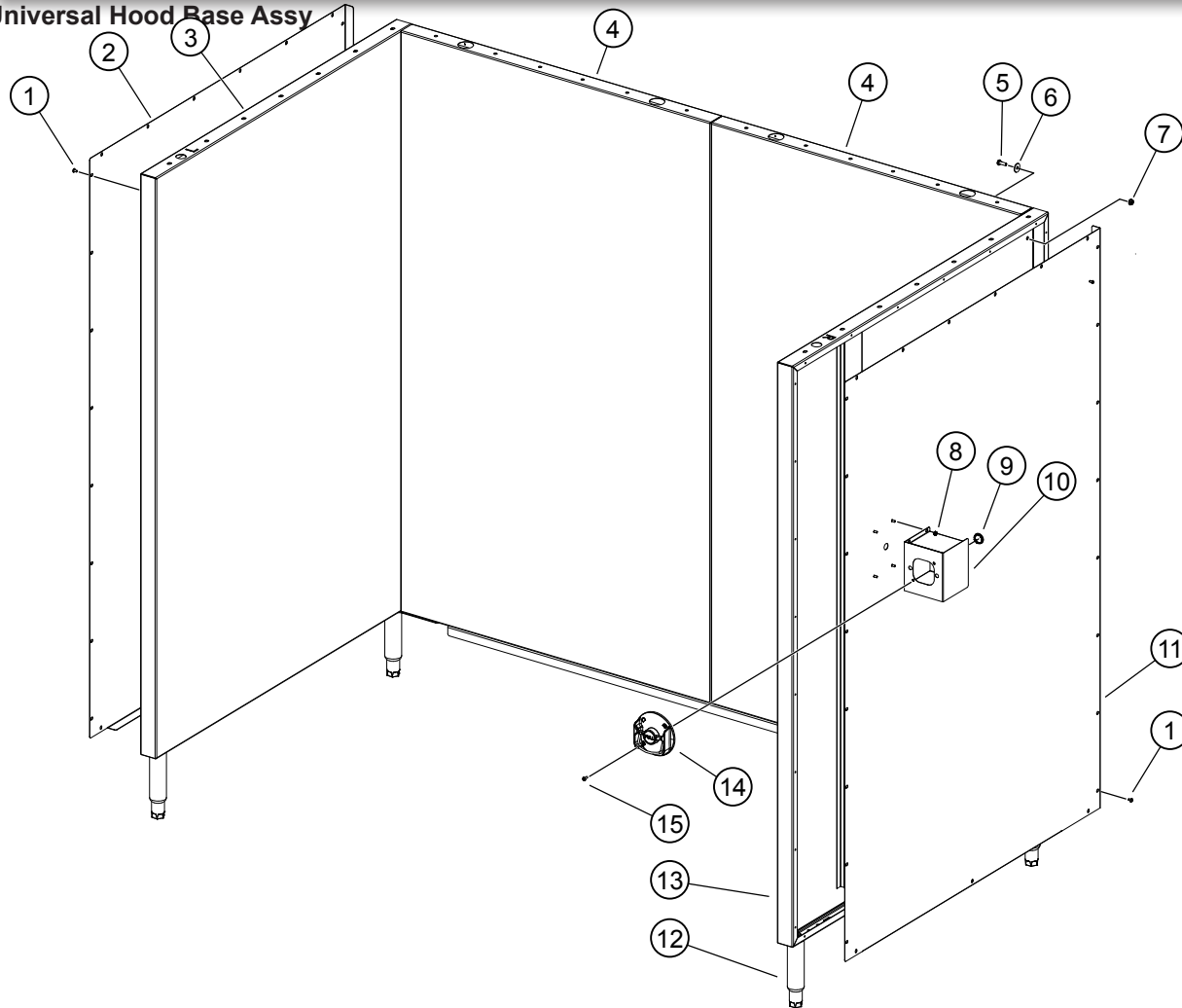

Model WVU-72: Universal Hood Base Assembly

Fig No.	Part Number	Quantity	Description
1	2C-31715	50	SCREW 8-32X5/16 PH RD HD
2	N1-Z14152	1	COVER, BASE SIDE LEFT
3	N1-WL0661	1	BASE, SUPPORT ASSY, LEFT
4	N1-Z19037	2	PANEL, REAR BASE SUPPORT
5	2C-Z5555	70	BOLT 1/4-20 X .75 HEX SS
6	2C-A27469	70	WASHER, FLAT 1/4IN 7/8OD 1
7	2C-6517	70	NUT 1/4-20 HEX STL NP
8	2C-31053	4	NUT 8-32 KEPS MS NICKEL
9	2P-70903-05	1	PLG BTN PLTD MTL 7/8
10	N1-WL0126	1	BOX, MANUAL PULL ASSEMBLY
11	N1-WL0180	1	COVER, BASE SIDE RT ASSY
12	2A-307628	4	LEG 6 ADJ 1/2-13 SS
13	N1-WL0662	1	BASE, SUPPORT ASSY RIGHT
14	2C-308131	1	REMOTE PULL STATION, RED
15	2C-31730	2	SCREW 8-32X1/2 PH TR HD M





265 Hobson Street • Smithville, TN 37166
 (800) 264-7827 • orders@wells-mfg.com



Application for Ventless Approvals

All Wells ventless models' dimensions, electrical requirements, and venting requirements are in the specification sheet and manuals. All documentation can be found at wells-mfg.com.com. Any questions please call Wells at (800) 264-7827

Please print or type. The application must be fully completed to be Approved. Please complete each section if applicable. Submit this application and all supporting documents with your PO.

Please supply documentation with application:

- Spec Sheets (equipment under the hoods) for non-Middleby brands
- Manuals (equipment under the hood)) for non-Middleby brands

NYC and Chicago

- Please contact a Wells representative to inquire about additional documentation

Customer Information

Business Name

Address		City	State	Zip
Phone Number	Mobile Number	Email Address		

Project Contact Information

Name	Email Address	Phone Number
Company		

Dealer Information

Name	Email Address	Phone Number
Company		

Wells Ventless

Model Number	How many pieces of equipment under hood	Project contact initial
1.		
2.		
3.		

PARTS & SERVICE

DESCRIPTION

PART NO.

IMPORTANT: Use only factory authorized service parts and replacement filters.

For factory authorized service, or to order factory authorized replacement parts, contact your Wells authorized service agency, or call:

Wells Manufacturing
265 Hobson St.
Smithville, TN 37166 USA

Service Dept.
phone: (800) 264-7827

Service Parts Department can supply you with the name and telephone number of the WELLS AUTHORIZED SERVICE AGENCY nearest you.

CUSTOMER SERVICE DATA

please have this information available if calling for service

RESTAURANT _____ LOCATION _____

INSTALLATION DATE _____ TECHNICIAN _____

SERVICE COMPANY _____

ADDRESS _____ STATE _____ ZIP _____

TELEPHONE NUMBER (____)____-_____

EQUIPMENT MODEL NO. _____ EQUIPMENT SERIAL NO. _____

VOLTAGE: (check one) 208 240



Wells Recirculating Ventless Hoods – Getting Started

Before you order a Wells Ventless System please review the following suggestions to ensure a trouble-free experience.

- Choose the model(s) that best suits your needs: (over 20 models to choose from)
- Read the specification sheet, owner's manual and watch the videos before ordering.
 - Available at wells-mfg.com
- Dimensions, Clearances, and Measurements: Verify the appliance will fit, that there is adequate vertical clearance and that the hood can be maneuvered into the space. Measure twice, order once.
- Ask Wells to check your equipment list to verify everything fits and is UL compliant.
 - Use all Star/Lang/Wells/Toastmaster/APW/Bakers Pride/Southbend equipment under the universal models will upgrade your warranty for FREE!
- Pull permits: Fire system, electrical and mechanical permits may be required in your area.
- HVAC: A well ventilated space is needed. We recommend you have an engineer or mechanical contractor review your plans and existing HVAC system.
- Electrical: Verify that sufficient electrical service is available to power the cooking equipment. Note that the control panels on some models require an interconnection with the cooking appliances that is not included.
- Fire Protection: Speak with a local licensed Ansul agent before ordering. Can they do a R-102 Fire suppression system? Does the building have a fire alarm panel? Is a remote pull required at way of egress? Charging and tagging the Ansul system must be performed by a licensed ANSUL agent and is not Wells responsibility.
 - WVU-31CT and WVC-46 require additional Ansul parts supplied by others.
- Wells Ventless systems are made-to-order and are non-refundable, so do your homework and ask questions. We are here to help.
- Fill out the Wells Ventless Application and turn in with your order.
- Place your order.

NOTES



Wells proudly supports CFESA
Commercial Food Equipment Service Association

SERVICE TRAINING - QUALITY SERVICE



CUSTOMER SATISFACTION



WELLS MANUFACTURING

265 Hobson Street, Smithville, Tennessee 37166

telephone: 800-264-7827

www.wells-mfg.com