

BA1TA SERIES

Winston Breeder/Sifter Table Owner's Manual

Series Includes:

BA1TA2

BA1TA4



2 | BREADER/SIFTER TABLE

WELCOME

If you have questions about your Winston Foodservice equipment, please contact your corporate office, local distributor, or Winston's Customer Care Center at 1.800.234.5286 or 1.502.495.5400, or email us at customercare@winstonind.com.

CONTACT INFORMATION:

www.winstonfoodservice.com

E-mail: customercare@winstonind.com

Phone: 1.800.234.5286 | 1.502.495.5400

Fax: 1.502.495.5458

Mail: 2345 Carton Drive | Louisville, KY 40299 USA

CONTENTS

Important Safety Information	2
Component Identification	3
Sifting	3
Breading	4
Daily Cleaning Procedure	4
Warranty & Terms and Conditions	5

WARNINGS AND INSTALLATION

INSTRUCTIONS

As is the case with most foodservice equipment, your Winston Breader/Sifter Table should be used with caution. Please read the following warnings to avoid potential injuries.

 **WARNING: Safety Hazard, Intended Use**
Can cause serious injury or damage to equipment.

Do not stand on equipment. Do not use equipment for any purpose other than its primary functions.

Have appliance serviced **ONLY** by a trained servicer. Do not allow personnel to utilize equipment while it is being serviced.

To prevent the hinged cover from falling when it is in the up and open position, be sure that it is locked in place with the drip pan.

Protective gloves should be worn to prevent burns associated with handling hot baskets from fryers.

Always perform daily cleaning procedures for this appliance. Build-up of food residue high in acid or chlorides can cause permanent damage to the stainless steel and can contaminate foods.

This equipment is not intended for use by persons (including children) with reduced physical, sensory, or mental capabilities, or lack of experience and knowledge, unless they have been given supervision or instruction concerning use of the equipment by a person responsible for their safety.

Children should be supervised to ensure that they do not play with the equipment.

This equipment is intended to be used for commercial applications, for example in kitchens of restaurants or institutions, in commercial operations such as bakeries, but not for continuous mass production of food.

It is the responsibility of the owner and installer to make sure that installation complies with all applicable local and state codes.



COMPONENT IDENTIFICATION

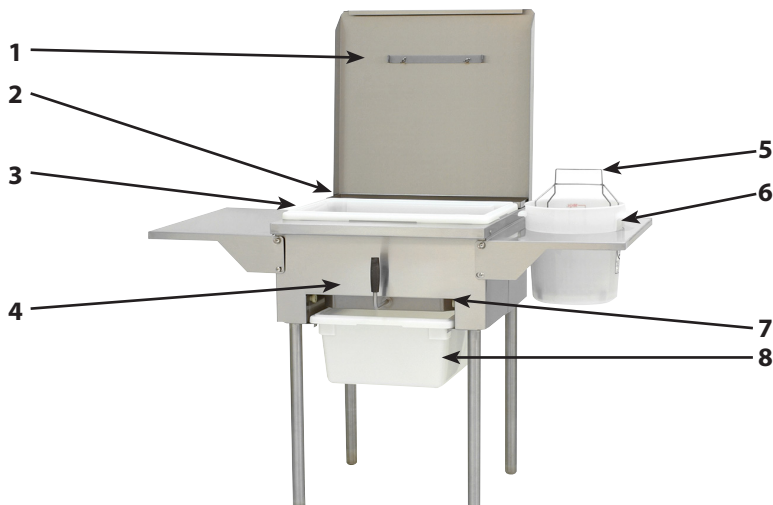

- | | |
|---|--|
| <ol style="list-style-type: none"> 1. Basket Hanger- used to hang basket. Provides easy loading after food product is breaded. 2. Drip Pan - Holds lid open and catches breadings and other debris spills while loading food product into basket. 3. Lug with Hole (Top Lug) - Product is breaded and used shortening remains are dispensed through hole for sifting. 4. Lug Hole Cover (not visible in photo) - Stainless steel plate used to cover hold in top lug. | <ol style="list-style-type: none"> 5. Dip Basket - Holds food product for dipping into dip bucket. 6. Dip Bucket - Holds water or other liquid to wet food product prior to breadings. 7. Sifter Screen (not visible) - Used to filter breadings from top lug. Separates dough balls and other debris from breadings. 8. Lug without Hole (Bottom Lug) - Used to catch clean breadings after it has been sifted. |
|---|--|

SIFTING

CAUTION: Contamination Hazard

Can cause illness >>> Prior to using equipment for the first time, perform the daily cleaning procedure on page 4.

1. Make sure lug hole cover is in top lug before breadings are poured into lug. Position sifter screen under lug hole. Place lug without hole in position under sifter screen.
2. Pour breadings into lug. Remove lug hole cover from top lug. Use lug hole cover to rake breadings through rectangular hole in bottom of lug.
3. Use handlebar on sifter screen to slide screen vigorously back and forth while sifting breadings from top to bottom lug (Figure 1).

4. When breadings are completely sifted, replace lug hole cover. Carefully pour breadings from bottom lug into top lug. Keep sufficient breadings in top lug to cover product.
5. After all breadings are sifted, remove sifter screen and discard dough balls and other debris.

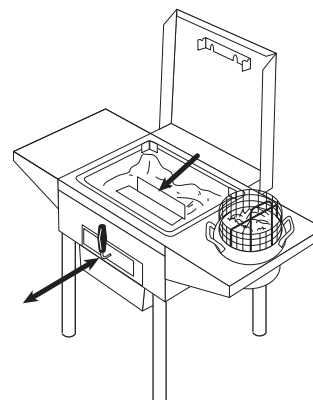

Figure 1

4 | BREADER/SIFTER TABLE

BREADING

CAUTION: Contamination Hazard

Can cause illness >> Prior to using equipment for the first time, perform the daily cleaning procedure below.

1. Before loading basket for the first cooking cycle of the day, dip clamshell basket into hot shortening; allow to drain. This prevents food product from sticking to the basket. Hook open clamshell basket on the basket hanger on back of cover (see Figure 2).
2. Load washed food product into dip basket; immerse into dip bucket of water (or other wetting liquid). Tilt and rest basket on edge of dip bucket to drain.
3. After excess liquid has drained off product, dump moist pieces into top breading lug. coat all pieces thoroughly with breading.

4. Remove breaded food product from lug and gently shake excess breading from product (Figure 2). Load breaded pieces onto top shelves of basket first. This allow loose breading particles to fall through basket into the lug. Place pieces close together, but do no overlap them.
5. Close loaded basket and use basket hook to lower basket into cooker. Follow your prescribed frying procedures.

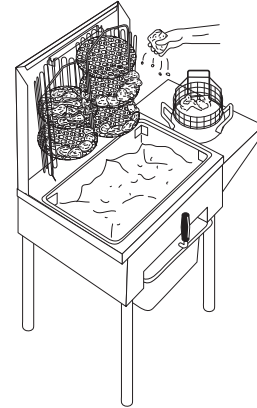

Figure 2

DAILY CLEANING

Required Cleaning Accessories and Supplies

- Spray hose
- Food grade germicidal agent.

WARNING: Contamination Hazard

Can cause serious illness >> Consumption of contaminated food has the potential to produce fatal illnesses. mandate food safety practices through daily cleaning procedure.

CAUTION: Contamination Hazard

Can cause serious illness >> Prior to using equipment for the first time, perform the daily cleaning procedure listed below.

PROCEDURE

Clean

1. Remove all loose-fitting parts, including the sifter screen.
2. Use a scrub brush, detergent, and hot water to clean all parts.
3. Rinse all parts with hot water to remove detergent.

Sanitize

1. Dip parts, or spray with 100-200ppm of chlorine sanitizing solution or food grade germicidal detergent. Allow parts to drain for five to ten minutes.
2. Rinse sanitizer from parts using hot water.
3. Let parts dry and reassemble breader/sifter.



WARRANTY AND TERMS & CONDITIONS

Limited 1 year Warranty (excluding gaskets, lamps, hoses, power cords, glass panels, fryer baskets, batteries, and evaporators). Warranty disclaimer for failure to clean.

WINSTON EXPRESSLY DISCLAIMS ALL OTHER WARRANTIES, EITHER EXPRESS OR IMPLIED, INCLUDING ANY IMPLIED WARRANTY OF FITNESS FOR A PARTICULAR PURPOSE AND ANY IMPLIED WARRANTY OF MERCHANTABILITY.

Ask us for a complete warranty disclosure or go to:

www.winstonind.com/Documents/4272V089_zap_warranty_agreement.pdf.

Terms and Conditions of Sale for Winston Foodservice' products are available here:

www.winstonind.com/Documents/4272X833_terms_and_conditions_of_sale.pdf.

Both the Warranty and Terms and Conditions of Sale are integral to this document.

Buy Winston Parts Online!

Parts and accessories for our products are available to purchase through our online, secure site – it's your one-stop shop for genuine Winston replacement parts. These parts are designed specifically for our products and can help you save on costly repairs while maintaining valuable warranty coverage.

www.winstonind.com/buyparts/.



Winston Foodservice is a Division of Winston Industries LLC

2345 Carton Drive | Louisville, KY 40299

800.234.5286 | +1.502.495.5400 | Fax +1.502.495.5458 | www.winstonfoodservice.com

