



SILVER SCREEN POPCORN MACHINES

INSTALLATION AND OPERATING INSTRUCTION MANUAL



For California Customers
WARNING: Cancer and Reproductive Harm - www.P65Warnings.ca.gov

Model	Voltage	Frequency	Power	Amperage	Plug Type	Overall Dimensions			Weight
						Width	Depth	Height	
11087	120V	60Hz	1490W	12.4A	NEMA 5-15P	19-3/4" 501mm	15-7/8" 401mm	29-3/4" 753mm	60 lbs (27.2kg)
11147			1740W	14.5A		24-1/8" 612mm	19-1/8" 485mm	36-5/8" 928mm	95 lbs (43.1kg)

BEFORE OPERATING ANY EQUIPMENT, READ AND FAMILIARIZE YOURSELF WITH THESE USE AND SAFETY INSTRUCTIONS

Congratulations on your purchase of this BenchmarkUSA™ commercial equipment. When used as intended, and with proper care and maintenance, you are sure to experience years of reliable operation from this equipment. To ensure best results, it is important that you read and follow the instructions in this manual carefully. It is important to keep these instructions in a safe place for future reference.

Important For Future Reference

Please complete this information and retain this manual for the life of the equipment. For Warranty Service and/or parts, this information is required.

Model Number

Serial Number

Date Purchased



WARNING: IMPROPER INSTALLATION, ADJUSTMENT, ALTERATION, SERVICE OR MAINTENANCE CAN CAUSE PROPERTY DAMAGE, INJURY, OR DEATH. READ THE INSTALLATION, OPERATION, AND MAINTENANCE INSTRUCTIONS THOROUGHLY BEFORE INSTALLING OR SERVICING THIS EQUIPMENT.

AVERTISSEMENT: TOUTE INSTALLATION, RÉGLAGE, MODIFICATION, RÉPARATION OU ENTRETIEN INCORRECT PEUT OCCASIONNER DES DOMMAGES MATÉRIELS, DES BLESSURES GRAVES OU LA MORT. LIRE LES INSTRUCTIONS D'INSTALLATION, D'UTILISATION ET D'ENTRETIEN ATTENTIVEMENT AVANT D'INSTALLER OU DE RÉPARER CET APPAREIL.



CAUTION: THESE MODELS ARE DESIGNED, BUILT, AND SOLD FOR COMMERCIAL USE ONLY. IF THESE MODELS ARE POSITIONED SO THE GENERAL PUBLIC CAN USE THE EQUIPMENT, MAKE SURE THAT CAUTION SIGNS, WARNINGS, AND OPERATING INSTRUCTIONS ARE CLEARLY POSTED NEAR EACH UNIT SO THAT ANYONE USING THE EQUIPMENT WILL USE IT CORRECTLY AND NOT INJURE THEMSELVES OR HARM THE EQUIPMENT.

ATTENTION: CES MODÈLES SONT CONÇUS, FABRIQUÉS, ET VENDUS POUR UN USAGE COMMERCIAL SEULEMENT. SI CES MODÈLES SONT PLACÉS POUR QUE LE GRAND PUBLIC PUISSE LES UTILISER, ASSUREZ-VOUS QUE LES CONSIGNES D'ATTENTION, D'AVERTISSEMENT, ET LES INSTRUCTIONS D'UTILISATION SOIENT CLAIEMENT AFFICHÉES PRÈS DE CHAQUE UNITÉ DE SORTE QUE N'IMPORTE QUEL UTILISATEUR DE L'APPAREIL L'EMPLOIE CORRECTEMENT ET NE SE BLESSE PAS OU N'ENDOMMAGE PAS L'APPAREIL.



WARNING: A FACTORY AUTHORIZED SERVICE PROVIDER SHOULD HANDLE ALL MAINTENANCE AND REPAIR. BEFORE DOING ANY MAINTENANCE OR REPAIR, FOLLOW SERVICE SET UP ARRANGEMENT ON PAGE 11.

AVERTISSEMENT: UN TECHNICIEN AUTORISÉ PAR L'USINE DEVRA EFFECTUER TOUT L'ENTRETIEN ET LES RÉPARATIONS. AVANT DE FAIRE TOUT ENTRETIEN OU RÉPARATION, VEUILLEZ CONTACTER WINCO.



Introduction

Congratulations on the purchase of your BenchmarkUSA™ Equipment. Please take time to carefully read through this manual to ensure the machine is operated and maintained properly, to ensure the best possible performance from the product for many years.

BenchmarkUSA™ will not accept liability for the following if:

- The instructions in this manual have not been followed correctly.
- Non-authorized personnel have tampered with the machine.
- Non-original spare parts are used.
- The machine has not been handled and cleaned correctly.
- There is any use damage to the unit.

Immediately Inspect for Shipping Damage

All containers should be examined for damage before and during unloading. The freight carrier has assumed responsibility for its safe transit and delivery. If equipment is received damaged, either apparent or concealed, a claim must be made with the delivering carrier.

- A. Apparent damage or loss must be noted on the freight bill at the time of delivery. It must then be signed by the carrier representative (Driver). If this is not done, the carrier may refuse the claim. The carrier can supply the necessary forms.
- B. If concealed damage or loss is not apparent until after equipment is uncrated, a request for inspection must be made to the carrier within 15 days. The carrier should arrange an inspection. Be certain to keep all contents and packaging material.

Table of Contents

Specifications	1
Warnings	2
Introduction	2
Packaging	3
Installation	4
Safety Precautions	5
Operation	5
Cleaning, Care & Maintenance	6
Troubleshooting	7
Service & Repair	7
Exploded View	8, 10
Spare Parts List	9, 11
Electrical Diagram	12
Limited Warranty	14

Package Contents

All units come with the following:

- BenchmarkUSA™ Silver Screen Popcorn Machine
- Operating Instruction Manual

BenchmarkUSA™ prides itself on quality and service, ensuring that at the time of packing, all products are supplied fully functional and free of damage. Should you find any damage as a result of freight, please contact your BenchmarkUSA dealer immediately.

Function and Purpose

This unit is intended to be used in commercial food-service operations only. It is not intended for household, industrial or laboratory use.

Installation and start-up must be performed by a qualified installer who has thoroughly read, understands and follows these instructions.

Please keep this manual in a safe place for future use!

NOTE

Please remember that this manual and the warning labels do not replace the need to be alert, to properly train and supervise operators, and to use common sense when using this equipment.

Installation

These instructions should be followed at all times. Failure to follow these instructions could result in injury to yourself and others.

WHEN USING ELECTRICAL APPLIANCES, BASIC SAFETY PRECAUTIONS AND COMMON SENSE SHOULD BE FOLLOWED, INCLUDING BUT NOT LIMITED TO THE FOLLOWING:

1. Read this manual thoroughly before installation and operation. DO NOT proceed with installation and operation if you have any questions or do not understand anything in this manual. Contact your representative or the manufacturer first.
2. DO NOT touch any surfaces that may be hot.
3. Unplug from outlet when not in use prior to installing or removing parts and before cleaning. Allow for the device to cool first before handling.
4. To protect against the risk of electrical shock, do not immerse the appliance, cord or plug in water, or other liquids.

	▲ WARNING ▲ Electrical Shock Hazard	▲ AVERTISSEMENT ▲ Risque de choc électrique
	Keep water and other liquids from entering the inside of the unit. Liquid inside the unit could cause an electrical shock. Do not spray water or cleaning products. Liquid could contact the electrical components and cause a short circuit or an electrical shock. Do not use unit if power cord is damaged or has been modified.	Conserver l'eau et d'autres liquides de pénétrer à l'intérieur de l'appareil. Liquide à l'intérieur de l'appareil pourrait provoquer un choc électrique. Ne pas pulvériser de l'eau ou des produits de nettoyage. Le liquide pourrait contacter avec les composants électriques et causer un court-circuit ou un choc électrique. Ne pas utiliser l'appareil si le cordon d'alimentation est endommagé ou a été modifié.

5. DO NOT operate this device or any other electrical equipment with a damaged cord or plug, or after the unit malfunctions, is dropped or damaged in any manner. Return to the nearest WINCO Authorized Service Center for examination, repair and/or adjustment.
6. The use of accessory attachments not recommended by WINCO may cause fire, electric shock or injury.
7. Not intended for outdoor installation.
8. DO NOT let the cord hang over the edge of a table or counter, or touch hot surfaces.
9. DO NOT place on or near a hot gas or electric burner, or in a heated oven.

	▲ WARNING ▲ Fire Hazard	▲ AVERTISSEMENT ▲ Risque d'incendie
	Correct installation precautions, procedures and regulations must be followed. Operation and safety training is necessary for all users of this equipment.	La surchauffe des vapeurs d'huile ou de l'huile peut s'enflammer et provoquer un incendie. Surveillez la température, la qualité et le niveau d'huile. Utilisez et entretenez le système d'élimination des vapeurs d'huile.

10. This appliance should always be on a stable and steady countertop or table. Allow sufficient space around the cooking area. Never use the unit on/near low-heat-resistant materials (carpet, vinyl).
11. This appliance is not intended for use by individuals (including children) with reduced or impaired physical, sensory or mental capabilities, or lack of experience or knowledge, unless they have been given proper supervision or instruction concerning the use of this appliance by a person responsible for their safety.
12. Clean the heated popping kettle with caution – if a wet sponge or cloth is used to wipe spills on a hot cooking surface, exercise caution to avoid steam burns. NOTE: some cleaners may produce noxious flames when applied to a hot surface.
13. Do not place metal objects such as knives, forks or spoons, in the heated popcorn kettle as they can break the motor, get hot and/or cause injury.
14. Do not store any item on top of this unit when in operation.
15. Never place materials such as paper, cardboard, plastic, etc. on or under this unit.
16. If an extension cord power-supply is used,
 - a. The marked electrical rating of the extension cord should be rated the same or greater than the electrical rating of the unit.
 - b. The cord should be located so that it will not drape over the countertop or tabletop where it can not be damaged or moved unintentionally.

Safety Precautions

Before installing and operating this equipment be sure everyone involved in its operation are fully trained and aware of all precautions. Accidents and problems can result from a failure to follow fundamental safety precautions.

- A WINCO® Approved Recommended Qualified Service Technician should carry out repairs if necessary. Do not remove any components or service panels on this product.
- Allow the unit to cool down after use before dismantling for cleaning; **the unit will be too hot to handle immediately after use.**
- Before cleaning, switch off power and disconnect power cord from the outlet.
- **Do not immerse unit in water or use hose to clean.**
Ne jamais immerger l'appareil dans l'eau ni utilisez un jet d'eau pour le nettoyer.
- If the power cord is damaged, it must be replaced by a WINCO® Approved Recommended Qualified Service Technician in order to avoid a hazard.

Operation

	<p>Proper Grounding USE A GROUNDED OUTLET DO NOT ADD AN ADAPTOR TO THE PLUG</p> <p>This machine is provided with a three-pronged grounding plug. The outlet to which this plug is connected must be properly grounded. If the receptacle is not the proper grounding type, contact an electrician. DO NOT, under any circumstances, cut or remove the third ground prong from the power cord or use any adapter plug.</p>	<p>Mise à la terre correcte UTILISER UNE PRISE AVEC MISE À LA TERRE NE PAS AJOUTER UN ADAPTATEUR SUR LA FICHE</p> <p>Cette machine est équipée d'une fiche à trois broches. La prise sur laquelle cette fiche est branchée doit être correctement mise à la terre. Si la prise n'est pas le type de mise à la terre, contactez avec un électricien. NE PAS, en aucun cas couper ou enlever la troisième broche de terre à partir du cordon d'alimentation ou utiliser un adaptateur.</p>
--	--	---

1. Plug the power cord into a properly grounded 120 volt power supply.
2. Make sure the kettle is installed in its upright and locked position, and there are no obstructions in the kettle.
3. Turn on the "MASTER" switch and the interior light will come on.
4. Turn on the "KETTLE" switch to heat the kettle and engage stirring motor. Allow kettle to preheat for 5 to 6 minutes.
5. Lift kettle lid and pour in kernels, oil, and seasonings.

▲ WARNING ▲

DO NOT add butter in kettle at any time while heating or when popcorn is popping.

If using butter, it should only be applied AFTER all kernels have popped and popcorn is removed from kettle.

6. Close the lid to prevent uncooked kernels and hot oil from ejecting out of the kettle.
7. Popcorn will start popping, overflowing out of the kettle into the tray below.
8. Once popping has stopped, open the lid and turn kettle to dump out remaining popcorn (there may be some un-popped kernels).
9. For additional batches repeat steps 5 through 8. It will not be necessary to wait 5 to 6 minutes since the kettle is already up to operating temperature.
10. Turn off switches when not in operation in order to maintain efficiency.

NOTE: Power switch to the kettle must be turned off when machine is not in use, to prevent damage to the kettle assembly.

Cleaning, Care & Maintenance

To maintain the appearance and increase the service life, this equipment must be cleaned and dried thoroughly. Clean all surfaces before use. Failure to clean surfaces before using the unit could cause food contamination.

The unit may require more frequent cleaning, depending on the volume of production.



▲ WARNING ▲
Burn Hazard

Please take extreme caution as kettle and the bottom floor of the unit will be HOT!
USE CAUTION WHEN TOUCHING THE UNIT.

▲ AVERTISSEMENT ▲
Risque de brûlure

Veillez faire preuve d'une extrême prudence car la bouilloire et le rez-de-chaussée de l'unité seront CHAUDS!
Soyez prudent lorsque vous touchez l'appareil.

KETTLE CLEANING, CARE AND MAINTENANCE

CAUTION: THE KETTLE IS REMOVABLE FROM THIS UNIT, BUT IT IS NOT INTENDED TO BE WASHED IN THE DISHWASHER OR IMMERSED IN WATER. IT WILL SHORT OUT THE ELECTRONIC COMPONENTS INSIDE AND VOID THE WARRANTY!

1. After popping the final batch, turn off the switches and unplug the unit, and let unit cool down before cleaning.
2. Always turn off the "KETTLE" switch after popping the final batch of a session. Leaving it on will burn any residue oil that is left in the kettle.
3. For routine cleaning: After popping the final batch of a session, use a damp cloth with warm, soapy water to wipe the excess oil from the interior and exterior of the kettle.
4. After cleaning, ensure that the kettle is plugged in correctly when reinstalling for proper operation.

CABINET CLEANING, CARE AND MAINTENANCE

1. After popping the final batch, turn off the switches and unplug the unit, and let unit cool down before cleaning.
2. Remove excess kernels and debris by wiping toward the crumb tray openings. After the inside has been wiped clean, remove the crumb tray and discard debris. It is recommended to clean the crumb tray prior to reinserting it into the unit.
3. The bottom tray and drop door are removable for easy cleaning in a sink. Use a mild detergent and water.
4. The interior of the popcorn maker should be cleaned after each use with a cloth and warm, soapy water.
5. The exterior of the unit may be cleaned by carefully wiping with a damp cloth. Use a standard glass cleaner for the glass panels and corner posts.
6. Clean off controls from any oil or debris using a damp cloth with warm soapy water. (Ensure that the controls are dry before use).

DO NOT immerse the device completely in water for any reason.

DO NOT use a pressure washer to clean.

NOTE: Proper cleaning instructions must be followed; otherwise, operation of the unit may be seriously impaired. Do not wash parts in an automatic dishwasher.

WINCO® authorized service personnel must perform any other servicing.

Troubleshooting

If your BenchmarkUSA™ Commercial Equipment does not operate, please check the following before placing a service call:

ISSUE	MIGHT BE CAUSED BY	RECOMMENDED SOLUTION
The unit is not turning on.	Power supply	Check power supply cord is correctly plugged in and outlet is working
	Power switch is off	Check that the unit is plugged in and turned on
	Plug/cord or external wiring damage	Remove and replace - Replacement must be done by an authorized Internal wiring fault service provider.
	Internal faulty wiring	
The switch light is on, mixer is running, but kettle is not heating up	Kettle may not be plugged in internally	Check that the flexible cable from the kettle is plugged into the receptacle on ceiling of internal cabinet
	Internal faulty wiring	Check connections going from the power switch to the kettle outlet - Replacement must be done by an authorized Internal wiring fault service provider.
	Internal kettle component failure	Remove kettle from cabinet and plug directly into a power outlet and check for heat.
Kettle mixer not turning	Motor/power switch not on	Ensure that you have clearly read the manual, to understand the operating functions
	Mixing shaft is locked or bent, causing the motor to stop spinning	Check that there is nothing obstructing the kettle mixer from rotating
	Faulty power switch	Remove and replace - Replacement must be done by an authorized Internal wiring fault service provider.
	Internal faulty wiring	Check connections between the motor and turn switch - Replacement must be done by an authorized Internal wiring fault service provider.
Internal light is not on	Light switch is in off position	Make sure the light switch is turned on
	Light bulb has burnt out	Replace bulb with same style light bulb
	Faulty socket	Inspect socket for any obstructions. Remove and replace as needed.
	Faulty power switch	Remove and replace - Replacement must be done by an authorized Internal wiring fault service provider.
	Internal wiring fault	Call WINCO to make service arrangements through their service provider network

Service and Repair

THIS EQUIPMENT MUST ONLY BE SERVICED BY AN AUTHORIZED AGENT.

NOTE

Parts protected by the manufacturer or its agent are not to be adjusted by the installer unless the installer is an authorized service agent.

If you have any questions or problems DO NOT send unit to WINCO® without first contacting our customer service department.

See "Limited Warranty" section on page 10 for details.

Exploded View

Model: 11087

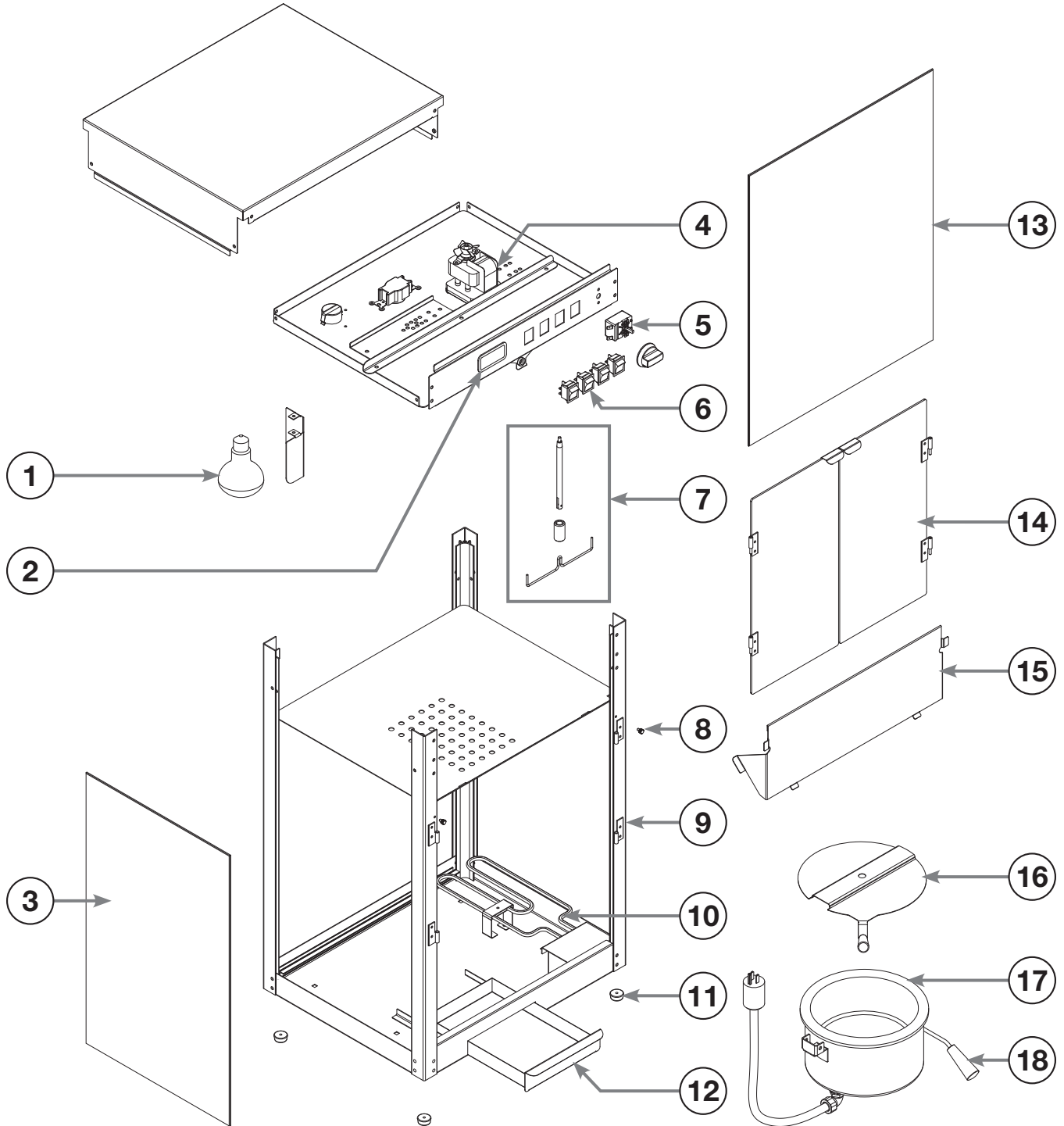

Parts List

		11087
No.	Description	Part #
1	45 Watt R20 Bulb	POP8-P7
2	Deck Temperature Indicator	47007
3	Side Glass	4001
4	120 Gear Motor	2018
5	Deck Warmer Thermostat	47006
6	Power Switch	2001
7	Mixer Assembly	5018
8	Thumb Screw (1 pc)	5028
9	Door Hinge Set	4020
10	100 Watt Cabinet Heater	1011
11	Rubber Foot (1 pc)	1234
12	Kernal Drawer	4006
13	Front Glass	4002
14	Door Set (Left & Right Plexi Doors / Handles / Hinges)	4010
15	Stainless Drop Door	4008
16	Kettle Lid	5008
17	Kettle (Kettle & Handle Assembly)	0018
18	Handle Assembly (Handle/Spring/Release Tab)	5021

Please contact factory for special order parts not listed.

Exploded View

Model: 11147

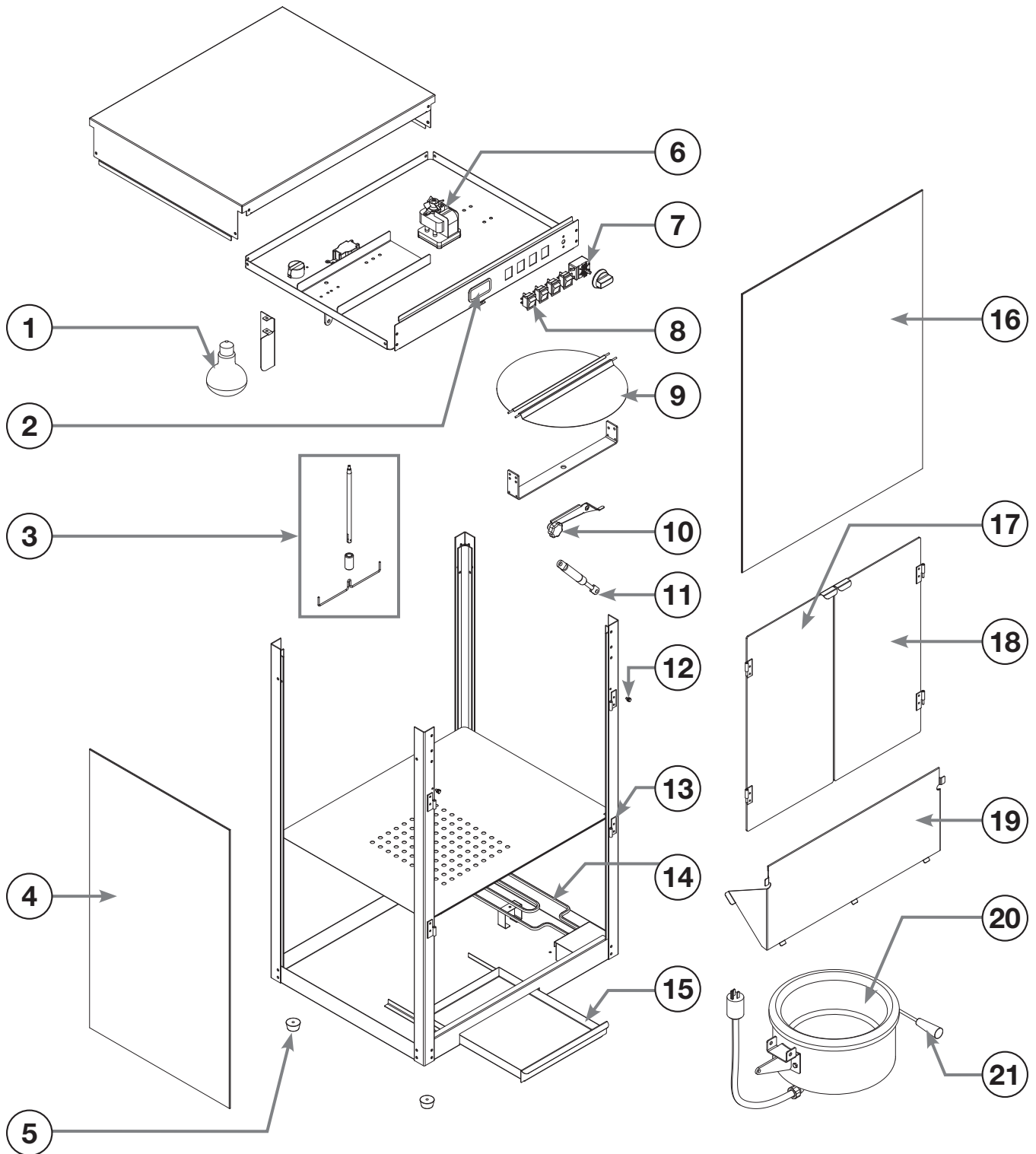

Parts List

		11147
No.	Description	Part #
1	45 Watt R20 Bulb	POP8-P7
2	Deck Temperature Indicator	47007
3	Mixer Assembly	47025
4	Side Glass	47012
5	Rubber Foot (1 pc)	1234
6	120V (50/60Hz) Gear Motor	2018
7	Deck Warmer Thermostat	47006
8	Power Switch	2001
9	Kettle Lid	47024
10	Lid Lift Handle	47027
11	Kettle Gas Spring	47028
12	Thumb Screw (1 pc)	5028
13	Door Hinge Set	4020
14	100 Watt Cabinet Heater	1011
15	Kernal Drawer	47016
16	Front Glass	47013
17	Left Door	47019
18	Right Door	47020
19	Stainless Drop Door	47018
20	Kettle (Kettle & Handle Assembly)	47024
21	Handle Assembly (Handle/Spring/Release Tab)	47026

Please contact factory for special order parts not listed.

Electrical Circuit Diagram

Models: 11087 and 11147

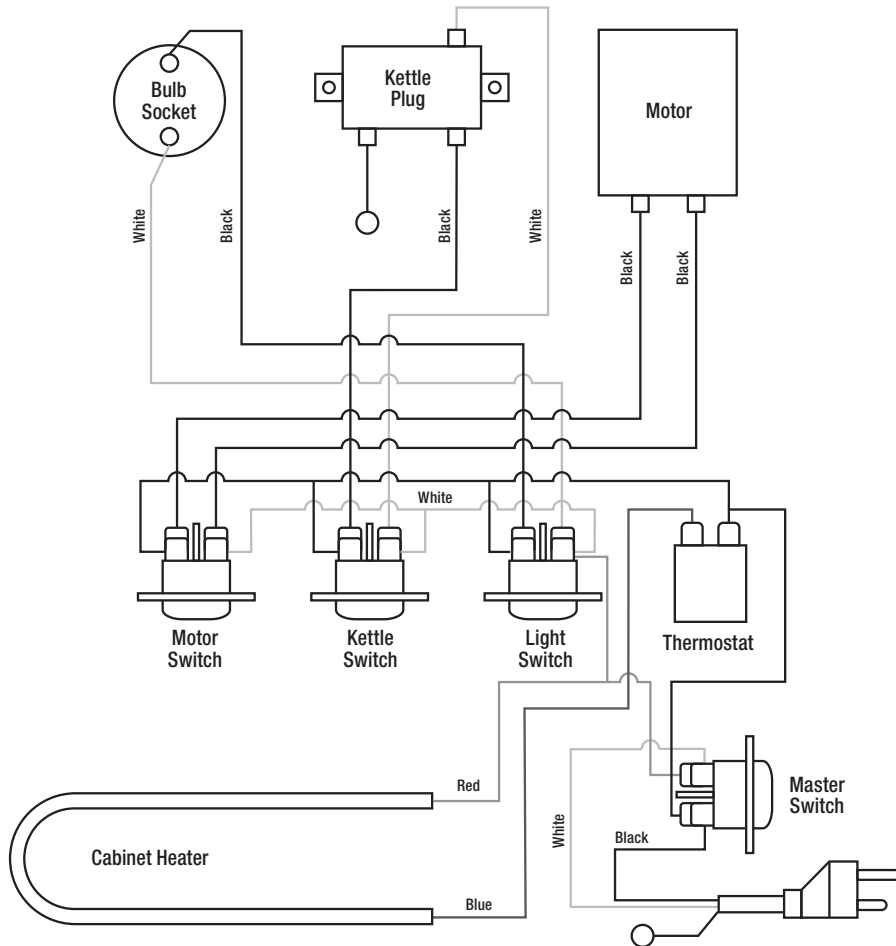

Limited Warranty & Equipment Warranty Registration

WINCO® warrants to the original purchaser of new equipment that said equipment, when installed in accordance with our instructions within North America and subjected to normal use, is free from defects in material or workmanship for a period of 1 year. The labor warranty is one year from original purchase date or 18 months from actual factory shipment date, whichever date occurs first.

THIS WARRANTY IS IN LIEU OF ALL OTHER WARRANTIES, WHETHER EXPRESSED OR IMPLIED. WINCO EXPRESSLY DISCLAIMS ANY IMPLIED WARRANTY OF MERCHANTABILITY OR EXPRESSED OR IMPLIED WARRANTY OF FITNESS FOR A PARTICULAR PURPOSE.

WINCO'S OBLIGATION AND LIABILITY UNDER THIS WARRANTY IS EXPRESSLY LIMITED TO REPAIRING AND REPLACING EQUIPMENT THAT PROVES TO BE DEFECTIVE IN MATERIAL OR WORKMANSHIP WITHIN THE APPLICABLE WARRANTY PERIOD.

IN NO EVENT SHALL WINCO BE LIABLE FOR INCIDENTAL OR CONSEQUENTIAL DAMAGES TO BUYER OR ANY THIRD PARTY, INCLUDING, WITHOUT LIMITATION, LOSS OF PROPERTY, PERSONAL INJURY, LOSS OF BUSINESS OR PROFITS OR OTHER ECONOMIC LOSSES, OR STATUTORY OR EXEMPLARY DAMAGES, WHETHER IN NEGLIGENCE, WARRANTY, STRICT LIABILITY, OR OTHERWISE.

This warranty is given only to the first purchaser from a retail dealer. No warranty is given to subsequent transferees.

Warranty does not cover product failures caused by: failure to maintain, neglect, abuse, damage due to excess water, fire, normal wear, improper set up and use. Periodic maintenance is not covered.

This warranty is not in force until such time as a properly completed and digitally signed Installation/Warranty Registration has been received by WINCO within 30 days from the date of installation.

WARRANTY SERVICE

DO NOT send unit to WINCO® without first contacting our customer service department: 973-295-3899.

To initiate warranty service please visit our online portal:
<https://www.winco.us.com/equipment-portal/>

SCAN FOR ONLINE PORTAL

If having trouble or unable to scan, enter the web address listed above to access the online portal.



Please provide or have the following information available:

- Contact Name, E-mail, and Phone Number
- Company/Organization Name
- Model Number
- Serial Number
- Pictures or Supporting Documentation

Proof of purchase is required to extend warranty more than 1 year from date of shipment from the factory.

THE FOREGOING WARRANTY PROVISIONS ARE A COMPLETE AND EXCLUSIVE STATEMENT BETWEEN THE BUYER AND SELLER. WINCO® NEITHER ASSUMES NOR AUTHORIZES ANY PERSONS TO ASSUME FOR IT ANY OTHER OBLIGATION OR LIABILITY IN CONNECTION WITH SAID EQUIPMENT.

Examples of items not covered under warranty, but not limited to just these items:

1. Natural disasters (ie: earthquakes, tornadoes, hurricanes, etc.), fire, water damage, burglary, accident, theft.
2. Freight damage.
3. Improper installation or alteration of equipment.
4. Use of generic or after-market parts.
5. Repairs made by anyone other than a WINCO® designated service provider.
6. Lubrication.
7. Expendable wear parts, adjustable feet, blown fuses, lamps, etc.
8. Normal product maintenance.
9. Misuse or abuse.
10. Normal wear and tear items such as light bulbs, fuses, and exterior finishes.

Warranty voided if:

1. Product is altered by user
2. Serial number plate is removed
3. Product is installed in a prison or any correctional facility.

Please keep this manual in a safe place for future use!



winco[®]
BENCH
MARK **USA**[™]

Models: 11087 and 11147

www.wincous.com