

winco® SPECTRUM™

ELECTRIC COUNTERTOP GRIDDLES

Installation and Operating Instruction Manual



EGD-16M



EGD-24M



EGD-36M



For California Customers

WARNING: Cancer and Reproductive Harm - www.P65Warnings.ca.gov

Model	Voltage	Power	Amperage see pg9 for 3-phase	Plug Type	Overall Dimensions			Temp Range	Weight
					Length	Depth	Height		
EGD-16M	120V ~50/60 Hz	1750W	14.6A	NEMA 5-15P	16" (406mm)	19-1/8" (486mm)	12-7/8" (327mm)	150°F - 480°F (65°C - 250°C)	53 lbs (24 kgs)
				NEMA 5-20P (Canada)					
EGD-24M	208/ 240V ~50/60 Hz	4200/ 5600W	20.2/23.4A 1-phase	NEMA L6-30P	24" (609mm)	21-3/4" (551mm)	12-7/8" (327mm)		
EGD-36M		6300/ 8400W	30.29/35A 1-phase	Field-wired by others				36" (914mm)	21-3/4" (551mm)

BEFORE OPERATING ANY EQUIPMENT, READ AND FAMILIARIZE YOURSELF WITH THESE USE AND SAFETY INSTRUCTIONS

Congratulations on your purchase of this SPECTRUM commercial equipment. When used as intended, and with proper care and maintenance, you are sure to experience years of reliable operation from this equipment. To ensure best results, it is important that you read and follow the instructions in this manual carefully. **It is important to keep these instructions in a safe place for future reference.**

Electric Countertop Griddles

Important For Future Reference

Please complete this information and retain this manual for the life of the equipment. For Warranty Service and/or parts, this information is required.

Model Number

Serial Number

Date Purchased



WARNING: For your safety, do not store or use gasoline or other flammable vapors or liquids in the vicinity of this or any other appliances. Keep the area free and clear of combustibles. (See ANSI Z83. 14B, 1991).

AVERTISSEMENT: Pour votre sécurité, ne pas stocker ni utiliser d'essence ou d'autres vapeurs ou liquides inflammables à proximité de cet appareil ou d'autres appareils. Garder la zone libre de combustible. (Voir la norme ANSI Z83. 14B, 1991).



WARNING: Improper installation, adjustment, alteration, service or maintenance can cause property damage, injury, or death. Read the installation operating and maintenance instructions thoroughly before installing, or servicing this equipment.

AVERTISSEMENT: Une installation, un réglage, une modification, un entretien ou peut causer des dommages matériels, des blessures ou la mort. Lisez les instructions d' exploitation et de maintenance d'installation avant d'installer, ou sauvegarder cet équipement.



WARNING: Instructions must be posted in a prominent location. All safety precautions must be taken in the event the user smells gas. Safety information can be obtained from your local gas supplier.

AVERTISSEMENT: Les instructions doit être affichées dans un endroit bien en vue. Toutes les mesures de sécurité doit être prises en cas d'odeur de gaz. Les consignes de sécurité peut être obtenue auprès de votre fournisseur de gaz local.



CAUTION: These models are designed, built, and sold for commercial use only. If these models are positioned so the general public can use the equipment, make sure that cautions, warnings, and operating instructions are clearly posted near each unit so that anyone using the equipment will use it correctly and not injure themselves or harm the equipment.

ATTENTION: Ces modèles sont conçus, fabriqués et vendus pour un usage commercial seulement. Si ces modèles sont positionnés de sorte que le grand public peut utiliser l'équipement, assurez-vous que mises en garde, les avertissements et les instructions sont clairement affichés unité de sorte que toute personne utilisant l'équipement va l'utiliser correctement et de ne pas nuire à injurethemselves ou l'équipement.



WARNING: A factory authorized agent should handle all maintenance and repair. Before doing any maintenance or repair, contact your authorized service representative.

AVERTISSEMENT: Un agent autorisé de l'usine doit traiter tout l'entretien et la réparation. Avant de faire tout entretien ou réparation, contactez votre représentant de service autorisé.



Electric Countertop Griddles

Table of Contents

Specifications 1

Warnings 2

Introduction 3

Packaging 4

Installation 5

Operation 6

Cleaning, Care & Maintenance 7

Exploded View & Parts List 8

Electrical Diagram 9

Troubleshooting 11

Service & Repair 11

Limited Warranty 12

Introduction

Congratulations on the purchase of your SPECTRUM™ equipment. Please take time to carefully read through this manual for proper operation and maintenance to ensure the best possible performance from the product for many years.

SPECTRUM will not accept liability for the following if:

- The instructions in this manual have not been followed correctly.
- Non-authorized personnel have tampered with the equipment.
- Non-original spare parts are used.
- The equipment has not been handled and cleaned correctly.
- There is any use damage to the unit.

LOCATION OF DATA PLATE

The data plate is located on the rear or side panel.

IMMEDIATELY INSPECT FOR SHIPPING DAMAGE

All containers should be examined for damage before and during unloading. The freight carrier has assumed responsibility for its safe transit and delivery. If equipment is received damaged, either apparent or concealed, a claim must be made with the delivering carrier.

- A. Apparent damage or loss must be noted on the freight bill at the time of delivery. It must then be signed by the carrier representative (Driver). If this is not done, the carrier may refuse the claim. The carrier can supply the necessary forms.
- B. If concealed damage or loss is not apparent until after equipment is uncrated, a request for inspection must be made to the carrier within 15 days. The carrier should arrange an inspection. Be certain to keep all contents and packaging material.

Installation should be performed by a qualified installer who thoroughly read, understands and follows these instructions.

If you have questions concerning the installation, operation, maintenance or service of this product, please contact WINCO®.

Please keep this manual in a safe place for future use!

Safety Precautions



DANGER: This symbol warns of imminent hazard which will result in serious injury or death.

Risque: Ce symbole avertit du danger imminent qui peut entraîner des blessures graves ou la mort.



WARNING: This symbol refers to a potential hazard or unsafe practice, which could result in serious injury or death.

AVERTISSEMENT: Ce symbole indique un danger potentiel ou une pratique dangereuse, qui peut entraîner des blessures graves ou la mort.



CAUTION: This symbol refers to a potential hazard or unsafe practice, which could result in minor or moderate injury or product or property damage.

ATTENTION: Ce symbole indique un danger potentiel ou une pratique dangereuse, qui peut entraîner des blessures mineures ou modérées ou des dommages matériels.



NOTICE: This symbol refers to information that needs special attention or must be fully understood even though not dangerous.

AVIS: Ce symbole renvoie à des informations qui nécessite une attention particulière ou doit être pleinement compris, même si pas dangereux.



NOTICE: This product is intended for commercial use only. Not for household use.

AVIS: Ce produit est destiné à un usage commercial. Pas pour usage domestique.



NOTICE: Local codes regarding installation vary greatly from one area to another. The National Fire Protection Association, Inc., states in its NFPA 96 latest edition that local codes are "Authority Having Jurisdiction" when it comes to requirement for installation of equipment. Therefore, installation should comply with all local codes.

AVIS: Les codes locaux concernant l'installation varient grandement d'une région à l'autre. La National Fire Protection Association, Inc., déclare dans sa dernière édition que NFPA 96 codes locaux sont "Autorité Compétente" lors de l'exigence pour l'installation d'équipements. Par conséquent, l'installation doit être conforme à tous les codes locaux.



Package Contents

All units come with Installation & Operating Instructions Manual and the following:

- (1) Griddle Unit
- (1) Catch Tray
- (4) Adjustable Legs

SPECTRUM prides itself on quality and service, ensuring that at the time of packing, all products are supplied fully functional and free of damage. Should you find any damage as a result of freight, please contact your SPECTRUM dealer immediately.

Installation and start-up must be performed by a qualified installer who has thoroughly read, understands and follows these instructions.

NOTE

Please remember that this manual and the warning labels do not replace the need to be alert, to properly train and supervise operators, and to use common sense when using this equipment.

Unpacking the Equipment

DISPOSE OF ALL PACKAGING MATERIALS IN AN ENVIRONMENTALLY RESPONSIBLE MANNER.

1. Remove all packing materials and tape, as well as any protective plastic and cardboard, from the unit.
2. Clean any glue residue left over from the plastic or tape.
3. Place the unit in the desired position and height.

SAVE THE ORIGINAL BOX AND PACKAGING FOR USE IN PACKAGING AND SHIPPING THE EQUIPMENT IF SERVICES ARE NEEDED.

Installation

These instructions should be followed at all times. Failure to follow these instructions could result in injury to yourself and others.

TO REDUCE RISK OF INJURY OR DAMAGE TO THE UNIT:



1. Read this manual thoroughly before installation and operation. **DO NOT** proceed with installation and operation if you have any questions or do not understand anything in this manual. Contact your representative or the manufacturer first.

WARNING  AVERTISSEMENT		
	<p>Fire Hazard. Correct installation precautions, procedures and regulations must be followed. Operation and safety training is necessary for all users of this equipment.</p>	<p>Risque d'incendie La surchauffe des vapeurs d'huile ou de l'huile peut s'enflammer et provoquer un incendie. Surveillez la température, la qualité et le niveau d'huile. Utilisez et entretenez le système d'élimination des vapeurs d'huile.</p>
	<p>The equipment must be installed by qualified personnel only. Correct installation precautions, procedures and regulations must be followed in order to reduce the risk of fire. Hood and fire suppression systems must be maintained per manufacturer's guidelines. Only qualified and trained personnel are to use this equipment.</p>	<p>Faire chauffer l'huile avec précaution. Si l'huile fume, réduire le feu. Ne pas laisser l'appareil sans surveillance. Si le feu se produit, éteindre l'appareil, couvrir jusqu'à refroidissement. Ne pas mettre l'eau dans l'huile chaude ou enflammée. Ne faites pas fonctionner avec de l'huile sous la barre d'huile. L'huile sale a un point d'éclair plus bas. Remplacer l'huile sur une base régulière. Maintenir le niveau d'huile correct. Utiliser un système d'évacuation de la vapeur d'huile (capot) pour réduire l'accumulation de graisse et d'huile sur les surfaces de paroi ou de plafond.</p>

NOTE

IF CERTIFIED RECEPTACLE IS REQUIRED, IT MUST BE INSTALLED BY A QUALIFIED ELECTRICIAN WHO IS FAMILIAR WITH ELECTRICAL PROCEDURES AND CODES. DO NOT ATTEMPT TO WIRE THIS GRIDDLE YOURSELF.

2. Remove the SPECTRUM Electric Griddle from the packaging. Be certain that all protective plastics and residues are thoroughly cleaned from its surface.
3. Place the SPECTRUM Electric Griddle on a firm level surface. Local standards and regulations should be consulted in order to abide by standards set in relation to positioning, spacing and ventilation.
4. Proper connections and power supply are necessary for satisfactory performance.
5. The external wiring must be in conduit or an approved type of flexible cable suitable for operation at temperature indicated at the conduit hole, and in a proper size to carry the load.
6. The supply circuit must be correctly fused and equipped with a means of disconnecting, as required by the local electrical code. For griddle with plugs and leads set, simply provide a suitable power point and connect.

WARNING  AVERTISSEMENT		
	<p>Burn Hazard. When in operation, the appliance will be hot. <i>Please take extreme caution.</i></p>	<p>Risque de brûlure. Ne touchez pas les surfaces chaudes ou chauffées liquid tout appareil chauffe ou en fonctionnement.</p>
	<p>USE CAUTION WHEN TOUCHING THE UNIT.</p>	<p>Ne touchez pas le liquide chaud ou les surfaces de chauffage lorsque l'appareil chauffe ou en fonctionnement.</p>

Leg Installation:

The Griddle must not be operated without the legs attached.

Install by screwing each leg post into each corner of unit frame. Level unit by turning lower foot clockwise or counter clockwise as required.

Leveling:

Turn the feet at the bottom of the legs (after legs are installed on unit) up or down to level the Griddle in the final installed location.

Assembly:

Slide the catch tray into the runners below the heating elements and place into the rack. Once in position, the catch tray will catch crumbs, grease or drippings from food product.

Seasoning the Griddle:

Heat to low temperature (300° - 350°F / 150° - 180°C) and pour a small amount of cooking oil onto the griddle plate (about one ounce { 30cc } per square foot of surface). Spread the oil over the entire griddle surface with a cloth to create a thin film. Wipe off any excess oil with a cloth. Repeat this procedure 2 to 3 times until the griddle has a slick, mirror-like surface. See "Operation" section for further step-by-step instructions.

Combustible clearances:

6" sides (152 mm) 6" rear (152 mm) 4" floor (102 mm)

Noncombustible clearances:

0" sides (0 mm) 6" rear (152 mm) 4" floor (102 mm)

THIS EQUIPMENT GETS EXTREMELY HOT!

DO NOT POSITION AND/OR OPERATE NEAR COMBUSTIBLE MATERIALS/FLAMMABLE OBJECTS.

Do not obstruct the flow of combustion and ventilation air, under the unit by the legs or behind the unit by the flue.

Ne pas obstruer le flux de combustion et de ventilation, sous l'unité par les jambes ou derrière l'appareil par la cheminée.

Adequate clearance for air openings into the combustion chamber is required. Do not place objects between the bottom of the unit and the counter top.

Un dégagement adéquat pour des ouvertures d'air dans la chambre de combustion est nécessaire. Ne pas placer d'objets entre le bas de l'appareil et le comptoir.

There must be adequate clearance for removal of the front panel. All major parts except the burners are removable through the front if the gas line is disconnected.

Il doit y avoir un espace suffisant pour le retrait de la face avant. Toutes les parties principales à l'exception des brûleurs sont amovibles à travers l'avant si la conduite de gaz est coupée.

TO AVOID SERIOUS PERSONAL INJURY:

- ALWAYS install equipment in an area with adequate light and space.
- ONLY operate on a solid, level, nonskid surface that is nonflammable and away from sinks and water hazards.
- NEVER bypass, alter or modify this equipment in any way from its original condition. Doing so can create hazards and will void warranty.
- NEVER operate the griddle without all warnings attached to it.

Operation

Before operating the griddle, it must be checked to see that it is sitting level. Adjust the feet to level the griddle. Be sure the catch tray has been assembled correctly (see image below).

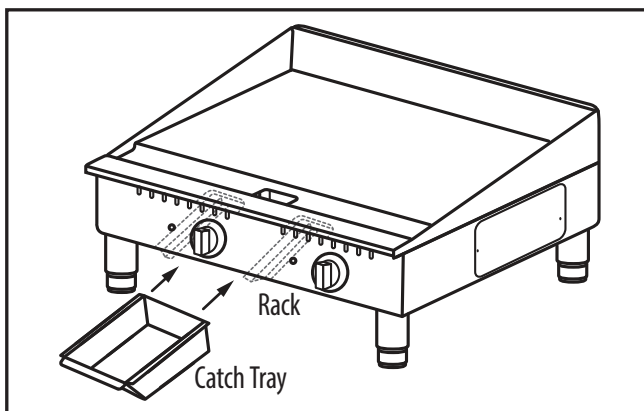

NOTE

Upon first use, griddle can produce a burning metal smell. This is normal. The smell will decrease with use.

Season the surface

1. Clean the griddle surface thoroughly. Once clean, it must be seasoned to prevent food from sticking. Follow the steps below for the correct heating method to season the griddle before use and after scouring.
2. Switch to ON and adjust the thermostat dial knob to 350°F.
3. Use a clean cloth (not a spatula), to spread a thick film of cooking oil or fat over the griddle cooking surface. Film must remain on hot griddle for 30 minutes.
4. Remove the excess fat and wipe clean.
5. Apply another film of cooking oil over hot cooking surface for another 30 minutes.
6. Remove the excess fat, wipe clean - the griddle surface is ready.



**CAUTION
 GRIDDLE SURFACE WILL BE HOT
 PLAQUE SURFACE SERA CHAUD**

NOTE

EVEN WITH CAREFUL SEASONING, FOOD CAN STICK TO THE GRIDDLE COOKING SURFACE UNTIL GRIDDLE PLATE IS "BROKEN IN".

Temperature Control

Your griddle should be turned on prior to usage to allow the cooking surface to warm up; 5-7 minutes is sufficient.

To get efficient use from this unit, it is recommended that for intermittent use that the thermostat be turned down when not cooking. This will assist in reducing power consumption and also allow for quicker heat response when needed.

It is recommended that the cooking surface is lightly greased before each use.

The temperature is thermostatically controlled.

The set point of each thermostat is marked on the front panel with "TEMP ▶" in the 9 o'clock position. Griddle is equipped with one thermostat per various cooking surface segments.

Cooking

Switch griddle to ON and adjust the thermostat dial knob to the desired temperature. After a short pre-heating period, the thermostat will automatically maintain the selected temperature. When the set temperature is reached, the signal light will go OFF.

A temperature setting of between 375°F and 430°F will be sufficient for general cooking. This may vary for particular food types, individual needs, or experience.

Simply place the food products on the grilling surface and cook to manufacturer's specifications.

Cleaning, Care & Maintenance

To maintain the appearance and increase the service life, clean your unit daily. The Electric Griddle should be cleaned after each day's operation - the unit may require more frequent cleaning depending on the volume of production.

WARNING ⚠ AVERTISSEMENT		
	Burn Hazard. When in operation, the appliance will be hot. <i>Please take extreme caution.</i>	Risque de brûlure. Ne touchez pas les surfaces chaudes ou chauffées liquid tout appareil chauffe ou en fonctionnement.
	USE CAUTION WHEN TOUCHING THE UNIT.	Ne touchez pas le liquide chaud ou les surfaces de chauffage lorsque l'appareil chauffe ou en fonctionnement.

1. Switch power off and disconnect from the outlet before cleaning.
2. Allow the Electric Griddle to cool down after use before dismantling for cleaning; the unit will still be too hot to handle immediately after use. Regular cleaning will result in easier cleaning, as the build up will be less. Correct preparation of the cooking surface when first used will assist in keeping the plates clean.
3. For best results clean the plate while still warm using warm soapy water. A nylon cleaning cloth may be used. It is recommended that

you avoid scrapers made of steel wool, as they will damage the plate. Do not use cold water on warm plates, as buckling effect may occur.

4. When scrubbing the plates, do not clean too thoroughly; if you do, you must prepare the cooking surface again before use.
5. Remove catch tray from unit and discard waste; clean with hot soapy water.
6. The remainder of the Electric Griddle can be cleaned with a damp cloth using warm, soapy water. Prolonged use of cleaning agents may cause damage to stainless steel.
7. Do not immerse completely in water or use hose to clean. *Ne pas immerger l'appareil dans l'eau ni utilisez un jet d'eau pour le nettoyer.*

WARNING ⚠ AVERTISSEMENT		
	Electrical Shock Hazard Keep water and other liquids from entering the inside of the unit. Liquid inside the unit could cause an electrical shock.	Risque de choc électrique Conserver l'eau et d'autres liquides de pénétrer à l'intérieur de l'appareil. Liquide à l'intérieur de l'appareil pourrait provoquer un choc électrique.
	Do not spray water or cleaning products. Liquid could contact the electrical components and cause a short circuit or an electrical shock. Do not use unit if power cord is damaged or has been modified.	Ne pas pulvériser de l'eau ou des produits de nettoyage. Le liquide pourrait contacter avec les composants électriques et causer un court-circuit ou un choc électrique. Ne pas utiliser l'appareil si le cordon d'alimentation est endommagé ou a été modifié.

RECOMMENDED CLEANING

A little effort goes a long way to keeping the griddle attractive and performing at top efficiency. If grease accumulates, it will build up and carbonize into a hard substance that is Extremely difficult to remove. Prevent this condition and follow the following cleaning steps:

PART	REQUIRED ACTION	FREQUENCY
Scraping	Scrape the griddle with a scraper / flexible spatula to remove excess fat & food. A catch tray is provided for the scrapings. If there is an accumulation of burned fat and food, griddle must be thoroughly scoured and re-seasoned. While the griddle is warm, use pumice or griddle stone to remove excess fat and food. Do not use steel wool because of the danger of steel slivers getting into the food.	After each use
Body	Use a clean cloth and a non-abrasive cleanser to clean the stainless steel griddle body. Wipe the polished areas with a soft cloth.	Daily
Controls	Griddle must be turned OFF when not in use. Switch griddle to OFF and disconnect power supply to griddle. Use a clean cloth to wipe down switches and thermostat dial knobs.	Daily
Catch tray	Once griddle has cooled, remove catch tray from griddle and discard the waste, debris and crumbs. CAUTION: <i>If catch tray is permitted to fill too high, the excess grease will run out of the overflow hole at the front of catch tray.</i> Remove the catch tray by pulling it forward. USE CAUTION WHEN FILLED WITH HOT GREASE!	Per use, or at least daily

Exploded View

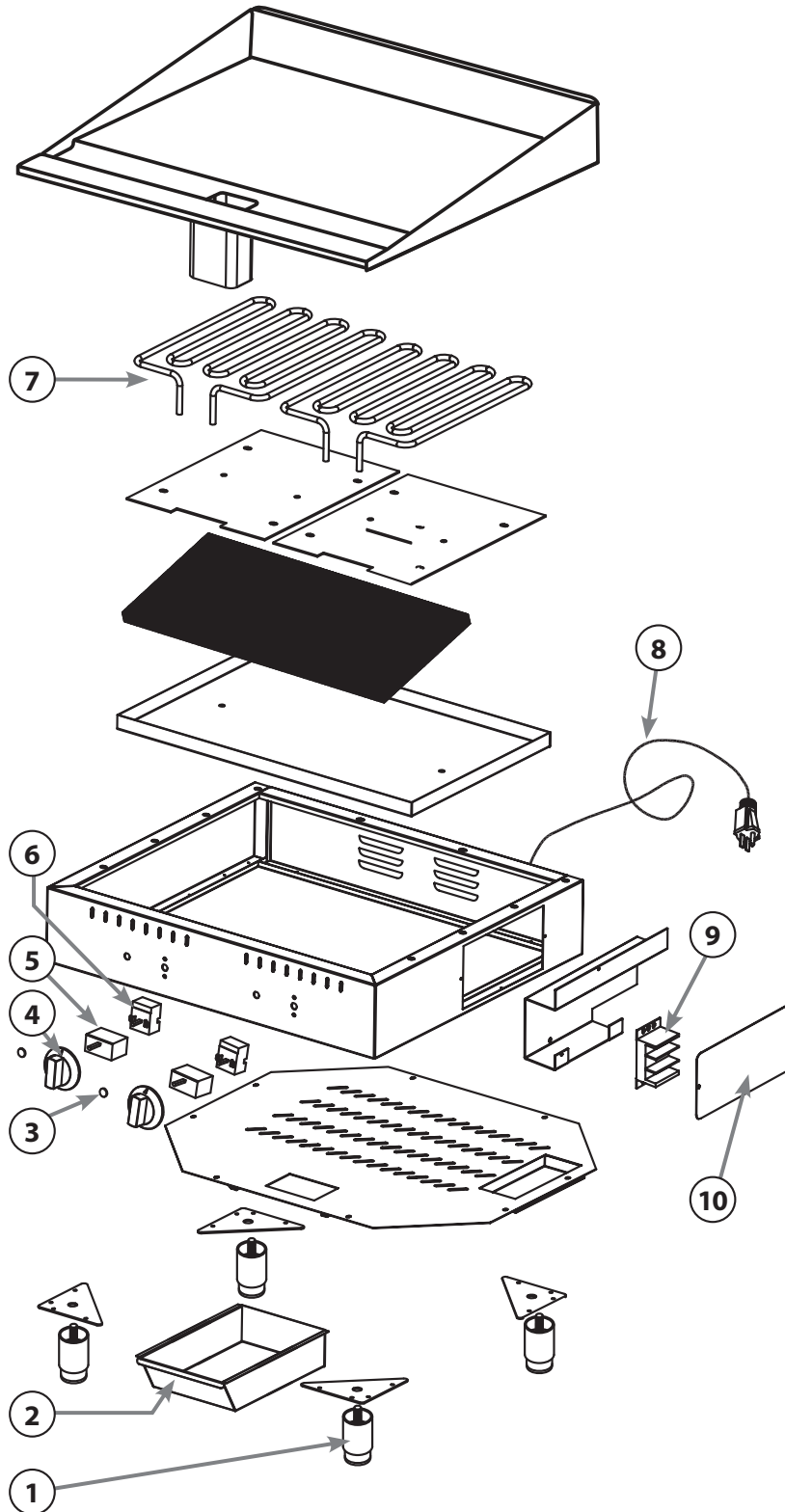

Parts List

		EGD-16M	EGD-24M	EGD-36M
No.	Description	Part #	Part #	Part#
1	Foot	EGD-MP1	EGD-MP1	EGD-MP1
2	Drip Tray	EGD-MP3	EGD-MP3	EGD-MP3
3	Indicator light	EGD-MP5	EGD-MP5	EGD-MP5
4	Dial	EGD-MP6	EGD-MP6	EGD-MP6
5	Switch	N/A	EGD-MP7	EGD-MP7
6	Thermostat	EGD-MP8	EGD-MP8	EGD-MP8
7	Heating Element	EGD-MP12	EGD-MP13	EGD-MP13
8	Plug & Lead	EGD-MP15-1	EGD-MP15-2	N/A
9	Terminal Block	EGD-MP16	EGD-MP17	EGD-MP17
10	Connection Box Cover	N/A	EGD-MP18	EGD-MP18
	Optional Power Cord with 5-20P Plug	EGD-MP19	N/A	N/A

Please contact factory for special order parts not listed.

Electrical Diagrams

The circuit diagrams are provided to assist qualified technicians. Only SPECTRUM agents or Recommended Qualified Technicians should carry out repairs if needed. (Refer to page 11 for service arrangements)

DO NOT remove any components or service panels on this product.

EGD-16M

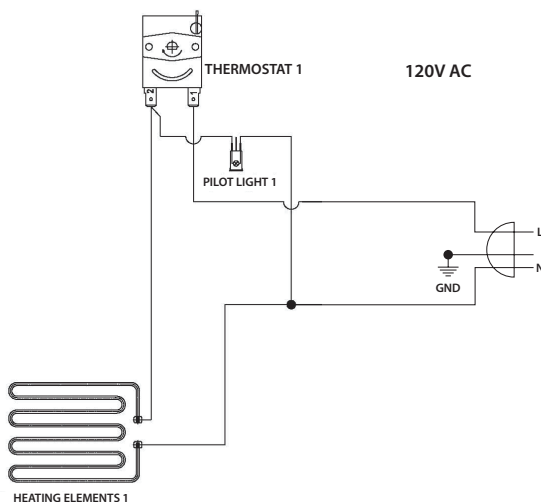

Electrical Diagrams

The circuit diagrams are provided to assist qualified technicians. Only SPECTRUM agents or Recommended Qualified Technicians should carry out repairs if needed. (Refer to page 11 for service arrangements)

DO NOT remove any components or service panels on this product.

EGD-24M

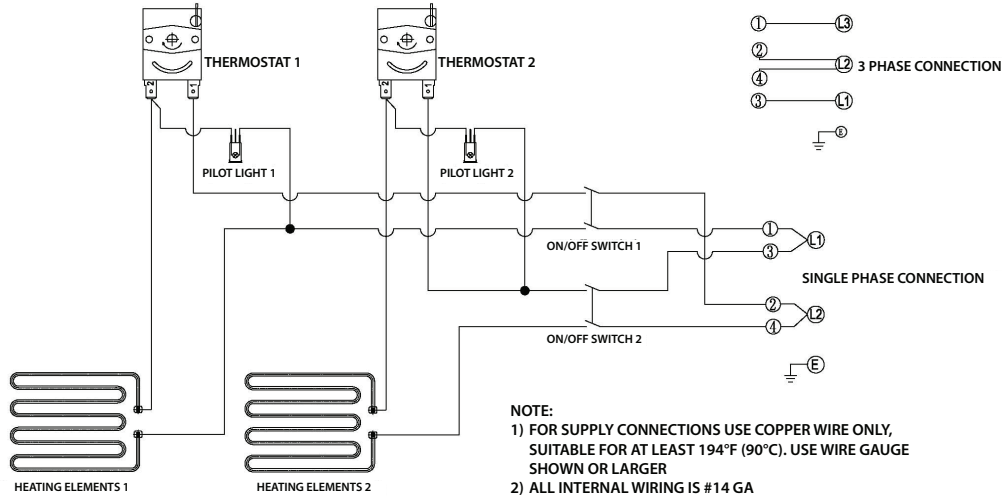

NOMINAL AMPS PER LINE							
208V ~ 3-PHASE			240V ~ 3-PHASE			208V	240V
4200 WATTS			5600 WATTS			1-PH	1-PH
L1	L2	L3	L1	L2	L3		
11.6	11.6	11.6	15.5	15.5	15.5	20.2	23.4
AWG #10	AWG #10	AWG #10	AWG #10	AWG #10	AWG #10	AWG #8	AWG #6

EGD-36M

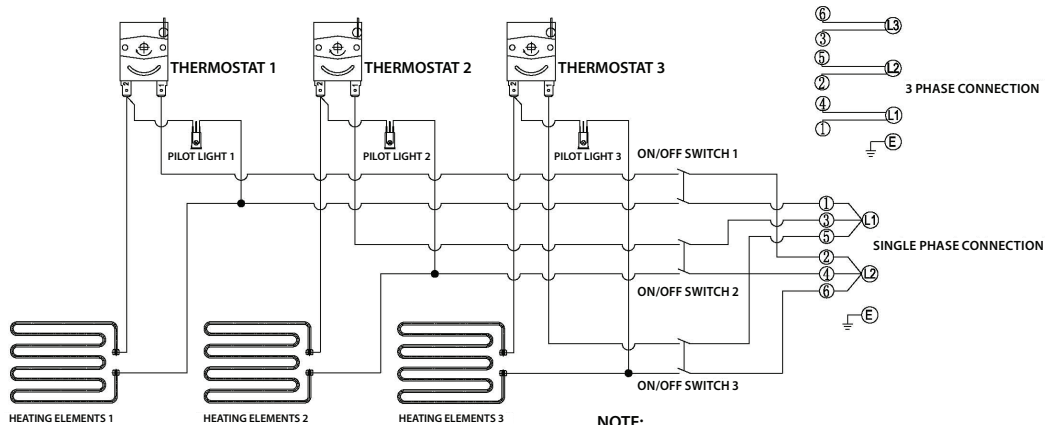

NOMINAL AMPS PER LINE							
208V ~ 3-PHASE			240V ~ 3-PHASE			208V	240V
6300 WATTS			8400 WATTS			1-PH	1-PH
L1	L2	L3	L1	L2	L3		
17.49	17.49	17.49	20.21	20.21	20.21	30.29	35
AWG #10	AWG #10	AWG #10	AWG #10	AWG #10	AWG #10	AWG #8	AWG #6

Troubleshooting

If your SPECTRUM Electric Griddle does not operate, please check the following before placing a service call:

ISSUE	MIGHT BE CAUSED BY	RECOMMENDED SOLUTION
The unit is not working	Power supply	Check power source
	Power switch has not been turned on	Check that the unit is correctly plugged in and turned on
	Plug/cord, set or external wiring is damaged	Remove and replace power cord - <i>Replacement must be done by an authorized service provider.</i>
	Internal wiring fault	Inspect that all connections are terminated and secure - <i>Replacement must be done by an authorized service provider</i>
The indicator light is on, but griddle is not heating up	Faulty heating elements	Remove & replace - <i>Replacement must be done by an authorized service provider.</i>
	Operation of thermostat All thermostats are not turned on	Make sure thermostat is set correctly and make sure dial is not spinning on the thermostat, giving the wrong reading
	Faulty thermostat	Check thermostat connections. Remove and replace if found faulty - <i>Replacement must be done by an authorized service provider.</i>
The indicator light is NOT on, but the griddle IS heating up	Faulty indicator light	Remove and replace - <i>Replacement must be done by an authorized service provider.</i>
Cooking Surface is heating up slowly	Carbon build up	Make sure that the plates are kept clean and free from carbon build up/debris
	Thermostat setting	Make sure thermostat is set correctly, & dial is not spinning on thermostat giving the wrong reading.
	Insufficient power	Check incoming power for correct voltage.
	Faulty heating elements	Remove & replace - <i>Replacement must be done by an authorized service provider.</i>
Food Sticking	Carbon build up	Make sure that the plates are kept clean and free from carbon build up/debris
	Not seasoned	Season grill, see Operating Instructions, page 5

Service and Repair

THIS EQUIPMENT MUST ONLY BE SERVICED BY AN AUTHORIZED AGENT.

There are no user serviceable parts within this appliance. To avoid serious injury or damage, do not remove any components or service panels on the product, never attempt to repair the unit, or replace a damaged power cord yourself. A WINCO Approved Qualified Service Technician should carry out repairs if they're necessary.

DO NOT send unit to WINCO without first contacting our customer service department. See "Limited Warranty" section on page 10 for details.

NOTE

Parts protected by the manufacturer or its agent are not to be adjusted by the installer unless the installer is an authorized service agent. If you have any questions or problems DO NOT send unit to WINCO® without first contacting our customer service department. See "Limited Warranty" section on page 11 for details.

Limited Warranty

WINCO® warrants to the original purchaser of new equipment that said equipment, when installed in accordance with our instructions within North America and subjected to normal use, is free from defects in material or workmanship for a period of 1 year. The labor warranty is one year from original installation or 18 months from actual factory shipment date, whichever date occurs first.

THIS WARRANTY IS IN LIEU OF ALL OTHER WARRANTIES, WHETHER EXPRESSED OR IMPLIED. WINCO EXPRESSLY DISCLAIMS ANY IMPLIED WARRANTY OF MERCHANTABILITY OR EXPRESSED OR IMPLIED WARRANTY OF FITNESS FOR A PARTICULAR PURPOSE.

WINCO'S OBLIGATION AND LIABILITY UNDER THIS WARRANTY IS EXPRESSLY LIMITED TO REPAIRING AND REPLACING EQUIPMENT THAT PROVES TO BE DEFECTIVE IN MATERIAL OR WORKMANSHIP WITHIN THE APPLICABLE WARRANTY PERIOD.

IN NO EVENT SHALL WINCO BE LIABLE FOR INCIDENTAL OR CONSEQUENTIAL DAMAGES TO BUYER OR ANY THIRD PARTY, INCLUDING, WITHOUT LIMITATION, LOSS OF PROPERTY, PERSONAL INJURY, LOSS OF BUSINESS OR PROFITS OR OTHER ECONOMIC LOSSES, OR STATUTORY OR EXEMPLARY DAMAGES, WHETHER IN NEGLIGENCE, WARRANTY, STRICT LIABILITY, OR OTHERWISE.

This warranty is given only to the first purchaser from a retail dealer. No warranty is given to subsequent transferees.

Warranty does not cover product failures caused by: failure to maintain, neglect, abuse, damage due to excess water, fire, normal wear, improper set up and use. Periodic maintenance is not covered.

This warranty is not in force until such time as a properly completed and digitally signed Installation/Warranty Registration has been received by WINCO within 30 days from the date of installation.

WARRANTY SERVICE

To initiate warranty service contact: EquipService@wincous.com or call: 973-295-3899

DO NOT send unit to WINCO® without first contacting our customer service department.

Please provide or have the following information available:

- Model & Serial Number
- Date of Purchase
- Purchase Dealer
- Operator / Installation Contact Information
- Business Name & Business Address
- Contact Name & Contact Telephone Number

REGISTER ONLINE AT: <http://www.wincous.com>

Proof of purchase is required to extend warranty more than 1 year from date of shipment from the factory.

THE FOREGOING WARRANTY PROVISIONS ARE A COMPLETE AND EXCLUSIVE STATEMENT BETWEEN THE BUYER AND SELLER. WINCO® NEITHER ASSUMES NOR AUTHORIZES ANY PERSONS TO ASSUME FOR IT ANY OTHER OBLIGATION OR LIABILITY IN CONNECTION WITH SAID EQUIPMENT.

Examples of items not covered under warranty, but not limited to just these items:

1. Natural disasters (ie: earthquakes, tornadoes, hurricanes, etc.), fire, water damage, burglary, accident, theft.
2. Freight damage.
3. Improper installation or alteration of equipment.
4. Use of generic or after-market parts.
5. Repairs made by anyone other than a WINCO® designated service provider.
6. Lubrication.
7. Expendable wear parts, adjustable feet, blown fuses, lamps, etc.
8. Cleaning of equipment.
9. Misuse or abuse.

Warranty voided if:

1. Product is altered by user
2. Serial number plate is removed
3. Product is installed in a prison or any correctional facility.

Please keep this manual in a safe place for future use!

Models: EGD-16M, EGD-24M, EGD-36M

www.wincous.com