

SPECTRUM

winco®

ROLLSRIGHT™ ELECTRIC COUNTERTOP COMMERCIAL HOT DOG ROLLER GRILL

Installation and Operating Instruction Manual



EHDG-5R



EHDG-7R



EHDG-11R

Optional curved glass
sneeze guards available
(sold separately)



Model	Voltage	Frequency	Power	Amperage	Plug Type	Overall Dimensions			Weight
						Length	Depth	Height	
EHDG-5R	110V	60Hz	700W	6.3A	NEMA 5-15P	23" (585mm)	10-1/2" (270mm)	7" (180mm)	16.3 lbs 7.4 kgs
EHDG-7R			900W	8.1A			13-1/2" (345mm)	7" (180mm)	20.2 lbs 9.2 kgs
EHDG-11R			1400W	12.7A			19-3/4" (505mm)	7" (180mm)	29 lbs 13.2 kgs

BEFORE OPERATING ANY EQUIPMENT, READ AND FAMILIARIZE YOURSELF WITH THESE USE AND SAFETY INSTRUCTIONS

Congratulations on your purchase of this SPECTRUM commercial roller grill. When used as intended, and with proper care and maintenance, you are sure to experience years of reliable operation from this equipment. To ensure best results, it is important that you read and follow the instructions in this manual carefully. It is important to keep these instructions in a safe place for future reference.

Electric Countertop Roller Grill

Important For Future Reference

Please complete this information and retain this manual for the life of the equipment. For Warranty Service and/or parts, this information is required.

Model Number

Serial Number

Date Purchased



WARNING: IMPROPER INSTALLATION, ADJUSTMENT, ALTERATION, SERVICE OR MAINTENANCE CAN CAUSE PROPERTY DAMAGE, INJURY, OR DEATH. READ THE INSTALLATION, OPERATION, AND MAINTENANCE INSTRUCTIONS THOROUGHLY BEFORE INSTALLING OR SERVICING THIS EQUIPMENT.

AVERTISSEMENT: TOUTE INSTALLATION, RÉGLAGE, MODIFICATION, RÉPARATION OU ENTRETIEN INCORRECT PEUT OCCASIONNER DES DOMMAGES MATÉRIELS, DES BLESSURES GRAVES OU LA MORT. LIRE LES INTRUCTIONS D'INSTALLATION, D'UTILISATION ET D'ENTRETIEN ATTENTIVEMENT AVANT D'INSTALLER OU DE RÉPARER CET APPAREIL.



CAUTION: THESE MODELS ARE DESIGNED, BUILT, AND SOLD FOR COMMERCIAL USE ONLY. IF THESE MODELS ARE POSITIONED SO THE GENERAL PUBLIC CAN USE THE EQUIPMENT, MAKE SURE THAT CAUTION SIGNS, WARNINGS, AND OPERATING INSTRUCTIONS ARE CLEARLY POSTED NEAR EACH UNIT SO THAT ANYONE USING THE EQUIPMENT WILL USE IT CORRECTLY AND NOT INJURE THEMSELVES OR HARM THE EQUIPMENT.

ATTENTION: CES MODÈLES SONT CONÇUS, FABRIQUÉS, ET VENDUS POUR UN USAGE COMMERCIAL SEULEMENT. SI CES MODÈLES SONT PLACÉS POUR QUE LE GRAND PUBLIC PUISSE LES UTILISER, ASSUREZ-VOUS QUE LES CONSIGNES D'ATTENTION, D'AVERTISSEMENT, ET LES INSTRUCTIONS D'UTILISATION SOIENT CLAIREMENT AFFICHÉES PRÈS DE CHAQUE UNITÉ DE SORTE QUE N'IMPORTE QUEL UTILISATEUR DE L'APPAREIL L'EMPLOIE CORRECTEMENT ET NE SE BLESSE PAS OU N'ENDOMMAGE PAS L'APPAREIL.



WARNING: A FACTORY AUTHORIZED SERVICE PROVIDER SHOULD HANDLE ALL MAINTENANCE AND REPAIR. BEFORE DOING ANY MAINTENANCE OR REPAIR, FOLLOW SERVICE SET UP ARRANGEMENT ON PAGE 11.

AVERTISSEMENT: UN TECHNICIEN AUTORISÉ PAR L'USINE DEVRA EFFECTUER TOUT L'ENTRETIEN ET LES RÉPARATIONS. AVANT DE FAIRE TOUT ENTRETIEN OU RÉPARATION, VEUILLEZ CONTACTER WINCO.



Introduction

Congratulations on the purchase of the SPECTRUM™ RollsRight™ Commercial Hot Dog Roller Grill. Please take time to carefully read through this manual to ensure the machine is operated and maintained properly, to ensure the best possible performance from the product for many years.

SPECTRUM will not accept liability for the following if:

- The instructions in this manual have not been followed correctly.
- Non-authorized personnel have tampered with the machine.
- Non-original spare parts are used.
- The machine has not been handled and cleaned correctly.
- There is any use damage to the unit.

Immediately Inspect for Shipping Damage

All containers should be examined for damage before and during unloading. The freight carrier has assumed responsibility for its safe transit and delivery. If equipment is received damaged, either apparent or concealed, a claim must be made with the delivering carrier.

- A. Apparent damage or loss must be noted on the freight bill at the time of delivery. It must then be signed by the carrier representative (Driver). If this is not done, the carrier may refuse the claim. The carrier can supply the necessary forms.
- B. If concealed damage or loss is not apparent until after equipment is uncrated, a request for inspection must be made to the carrier within 15 days. The carrier should arrange an inspection. Be certain to keep all contents and packaging material.

Electric Countertop Roller Grill

Table of Contents

Specifications.....	1
Warnings	2
Introduction	2
Packaging	3
Installation	4
Operation	5
Optional Accessories	5
Cleaning, Care & Maintenance	6
Safety	6
Troubleshooting	7
Service & Repair	7
Exploded View	8
Spare Parts List	9
Electrical Diagram	10
Assembly Instructions - sneeze guards	11
Limited Warranty	12

Package Contents

All units come with an Operating Instruction Manual and the following:

- SPECTRUM™ RollsRight™ Commercial Hot Dog Roller Grill
- Drip Tray

SPECTRUM prides itself on quality and service, ensuring that at the time of packing, all products are supplied fully functional and free of damage. Should you find any damage as a result of freight, please contact your SPECTRUM dealer immediately.

Unpacking the Equipment

DISPOSE OF ALL PACKAGING MATERIALS IN AN ENVIRONMENTALLY RESPONSIBLE MANNER.

1. Remove all packing materials and tape, as well as any protective plastic and cardboard, from the unit.
2. Clean any glue residue left over from the plastic or tape.
3. Place the unit in the desired position and height.

Installation and start-up must be performed by a qualified installer who has thoroughly read, understands and follows these instructions.

Please keep this manual in a safe place for future use!

NOTE

Please remember that this manual and the warning labels do not replace the need to be alert, to properly train and supervise operators, and to use common sense when using this equipment.

Installation

These instructions should be followed at all times. Failure to follow these instructions could result in injury to yourself and others.

TO REDUCE RISK OF INJURY OR DAMAGE TO THE UNIT:

1. Read this manual thoroughly before installation and operation. DO NOT proceed with installation and operation if you have any questions or do not understand anything in this manual. Contact your representative or the manufacturer first.

WARNING ⚠️ AVERTISSEMENT	
	<p>Fire Hazard. Correct installation precautions, procedures and regulations must be followed. Operation and safety training is necessary for all users of this equipment.</p> <p>The equipment must be installed by qualified personnel only. Correct installation precautions, procedures and regulations must be followed in order to reduce the risk of fire. Hood and fire suppression systems must be maintained per manufacturer's guidelines. Only qualified and trained personnel are to use this equipment.</p>
	<p>Risque d'incendie La surchauffe des vapeurs d'huile ou de l'huile peut s'enflammer et provoquer un incendie. Surveillez la température, la qualité et le niveau d'huile. Utilisez et entretenez le système d'élimination des vapeurs d'huile.</p> <p>Faire chauffer l'huile avec précaution. Si l'huile fume, réduire le feu. Ne pas laisser l'appareil sans surveillance. Si le feu se produit, éteindre l'appareil, couvrir jusqu'à refroidissement. Ne pas mettre l'eau dans l'huile chaude ou enflammée. Ne faites pas fonctionner avec de l'huile sous la barre d'huile. L'huile sale a un point d'éclair plus bas. Remplacer l'huile sur une base régulière. Maintenir le niveau d'huile correct. Utiliser un système d'évacuation de la vapeur d'huile (capot) pour réduire l'accumulation de graisse et d'huile sur les surfaces de paroi ou de plafond.</p>

2. Remove the SPECTRUM™ Commercial Hot Dog Roller Grill from the packaging. Be certain that all protective plastics and residues are thoroughly cleaned from its surface.
3. Place Roller Grill on a firm level surface; the adjustable feet can assist in leveling.
Local standards and regulations should be consulted in order to abide by standards set in relation to positioning, spacing, and ventilation. SPECTRUM recommends that you allow no less than 4" for a ventilation gap around the perimeter of this unit. Common sense should be used when choosing position and operation of this product.



CAUTION



ATTENTION

Do not position or operate near combustible materials/flammable objects.

Ne pas placer ni faire fonctionner l'appareil près de matériels combustibles ou d'objets inflammables.

Once your Hot Dog Roller has been placed in position, be sure that the stainless steel drip tray is correctly positioned.

Une fois que votre Machine à Hot-Dog à Rouleau est mise en place, veillez à ce que le bac à déchets en acier inoxydable soit correctement placé.

WARNING ⚠️ AVERTISSEMENT	
	<p>Electrical Shock Hazard Keep water and other liquids from entering the inside of the unit. Liquid inside the unit could cause an electrical shock.</p> <p>Do not spray water or cleaning products. Liquid could contact the electrical components and cause a short circuit or an electrical shock. Do not use unit if power cord is damaged or has been modified.</p>
	<p>Risque de choc électrique Conserver l'eau et d'autres liquides de pénétrer à l'intérieur de l'appareil. Liquide à l'intérieur de l'appareil pourrait provoquer un choc électrique.</p> <p>Ne pas pulvériser de l'eau ou des produits de nettoyage. Le liquide pourrait contacter avec les composants électriques et causer un court-circuit ou un choc électrique. Ne pas utiliser l'appareil si le cordon d'alimentation est endommagé, ou a été modifié.</p>

4. Once the Roller Grill has been placed in position, be sure that the stainless steel drip tray is correctly positioned.
5. **Proper connections and power supply are essential for efficient performance.** Supply the appropriate power and connect to source; your Roller Grill is now ready to turn on and operate. (For power supply please see technical specification on page 1).
Fournir l'alimentation secteur appropriée et brancher l'appareil à la source d'alimentation ; votre Machine à Hot-Dog à Rouleau est maintenant prête à être allumée et à fonctionner. (Pour l'alimentation, veuillez voir la fiche technique, page 1).
6. The units are wired to be used with a standard 110V/AC receptacle and may be plugged into any convenient outlet.

Proper Grounding · Mise à la terre correcte

This machine is provided with a three-pronged grounding plug. The outlet to which this plug is connected must be properly grounded. If the receptacle is not the proper grounding type, contact an electrician. DO NOT, under any circumstances, cut or remove the third ground prong from the power cord or use any adapter plug.

Cette machine est équipée d'une fiche à trois broches. La prise sur laquelle cette fiche est branchée doit être correctement mise à la terre. Si la prise n'est pas le type de mise à la terre, contactez avec un électricien. NE PAS, en aucun cas couper ou enlever la troisième broche de terre à partir du cordon d'alimentation ou utiliser un adaptateur.

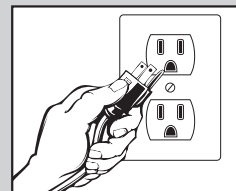

**USE A GROUNDED OUTLET
DO NOT ADD AN ADAPTOR
TO THE PLUG**

**UTILISER UNE PRISE AVEC MISE
À LA TERRE NE PAS AJOUTER UN
ADAPTEUR SUR LA FICHE**

7. The installation of the unit must conform to the NATIONAL ELECTRIC CODE, ALL LOCAL ELECTRIC CODES AND ORDINANCES, AND ALL THE LOCAL ELECTRICAL COMPANY RULES AND REGULATIONS. Additionally, we recommend a 4" spacing surrounding the unit in order to provide adequate ventilation.

Operation

Preparing the rollers

The rollers are coated with Teflon™, a superior fluoropolymer coating. It has excellent resistance to wear and to all forms of abrasion. To clean, simply use a damp cloth and soapy water.

During the manufacturing process oils are used to prevent rusting. During final processing the rollers are coated with food safe oil. However, it is strongly recommended the rollers are thoroughly cleaned before first use.

Be sure the cooking surface is clean; using a damp cloth and soapy water, turn gently while wiping down the rollers, then allow to dry.

It is recommended that the cooking surface be lightly greased before every use.

Operating the roller grill



The SPECTRUM™ Commercial Roller Grill should be turned on and preheated prior to using, to allow the cooking surface to warm up - 5 to 7 minutes should be sufficient.

For more efficient use, it is recommended that when using the unit intermittently, the energy control should be turned to low when not cooking or powered off. This will assist in reducing power consumption and also allow for quicker heat response when needed.

The unit is equipped with one rocker switch for On/Off POWER. This switch activates main power to the unit and rollers movement. When POWER switch is on, rollers will turn with or without heat.

- **The POWER switch does not activate heat, only turns unit On or Off.**
- **When POWER switch is On, rollers will turn with or without heat.**
- **Heat is controlled by the Temperature dials (C in diagram).**
- Each temperature control dial controls either the FRONT or BACK section of the unit, as indicated on the control panel:
 - A. On/Off Switch Main power switch and roller activation
 - B. Heat Lights Indicates heating up to reach temperature
 - C. Dial Controls Temperature adjustment

The HEAT indicator lights on the front panel indicate that the roller is heating, either one section, or both front and back. If the heat lights are off, this indicates the rollers have reached desired temperature, or have been turned off from the power switch.

 HOT	WARNING  AVERTISSEMENT			
	<table border="1" style="width: 100%;"> <tr> <td style="width: 50%; vertical-align: top;"> Burn Hazard. When in operation, the appliance surfaces will be HOT! <i>Please take extreme caution.</i> </td> <td style="width: 50%; vertical-align: top;"> Risque de brûlure. En fonctionnement, les surfaces de l'appareil seront CHAUDES! <i>S'il vous plaît prendre une extrême prudence.</i> </td> </tr> <tr> <td style="vertical-align: top;"> USE CAUTION WHEN TOUCHING THE UNIT. </td> <td style="vertical-align: top;"> Ne touchez pas le liquide chaud ou les surfaces de chauffage lorsque l'appareil chauffe ou en fonctionnement. </td> </tr> </table>	Burn Hazard. When in operation, the appliance surfaces will be HOT! <i>Please take extreme caution.</i>	Risque de brûlure. En fonctionnement, les surfaces de l'appareil seront CHAUDES! <i>S'il vous plaît prendre une extrême prudence.</i>	USE CAUTION WHEN TOUCHING THE UNIT.
Burn Hazard. When in operation, the appliance surfaces will be HOT! <i>Please take extreme caution.</i>	Risque de brûlure. En fonctionnement, les surfaces de l'appareil seront CHAUDES! <i>S'il vous plaît prendre une extrême prudence.</i>			
USE CAUTION WHEN TOUCHING THE UNIT.	Ne touchez pas le liquide chaud ou les surfaces de chauffage lorsque l'appareil chauffe ou en fonctionnement.			

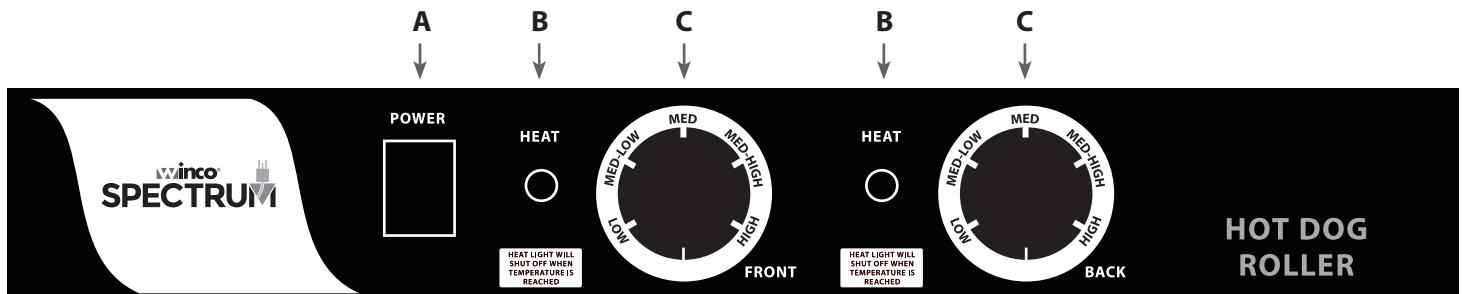

Optional Accessories

Curved glass sneeze guards are available sized to fit each roller grill unit.

See assembly instructions on page 11

Sneeze guards sold separately:

EHDG-5SG / EHDG-7SG / EHDG-11SG



EHDG-7SG sneeze guard shown on EHDG-7R roller grill

Cleaning, Care & Maintenance

To maintain the appearance and increase the service life, clean your unit daily.

The SPECTRUM™ Commercial Hot Dog Roller Grill should be cleaned after each day's operation; however, the unit may require more frequent cleaning, depending on the volume of production.

WARNING  AVERTISSEMENT	
 HOT	Burn Hazard. When in operation, the appliance surfaces will be HOT! <i>Please take extreme caution.</i>
	Risque de brûlure. En fonctionnement, les surfaces de l'appareil seront CHAUDES! <i>S'il vous plaît prendre une extrême prudence.</i>
USE CAUTION WHEN TOUCHING THE UNIT.	Ne touchez pas le liquide chaud ou les surfaces de chauffage lorsque l'appareil chauffe ou en fonctionnement.

1. Switch power off and disconnect from the outlet before cleaning.
2. The Roller Grill should be cleaned regularly throughout use, and thoroughly cleaned after each meal period.
3. For best results clean the rollers while still warm using warm soapy water. A nylon cleaning cloth may be used, but it is recommended that you avoid scrapers made from steel or wool, as they will damage the cooking surface of the rollers. Do not use cold water. Leave the catch trays in while cleaning.
4. Using a moist cloth filled with crushed or flaked ice, wipe each tube. Wipe the tubes from each end to the center. This will keep as much of the loosened particles out of the bearings as possible. Extend the cloth as far as possible between the rollers.
5. Wipe clean with another clean cloth. Continue to wipe from the end of the rollers to the center. This will reduce the grease and particles getting into the bearings and drive mechanism. This will also extend the life of the unit and the period between routine maintenance of the drive mechanism.

WARNING  AVERTISSEMENT	
	Electrical Shock Hazard Keep water and other liquids from entering the inside of the unit. Liquid inside the unit could cause an electrical shock.
	Risque de choc électrique Conserver l'eau et d'autres liquides de pénétrer à l'intérieur de l'appareil. Liquide à l'intérieur de l'appareil pourrait provoquer un choc électrique.
Do not spray water or cleaning products. Liquid could contact the electrical components and cause a short circuit or an electrical shock. Do not use unit if power cord is damaged or has been modified.	Ne pas pulvériser de l'eau ou des produits de nettoyage. Le liquide pourrait contacter avec les composants électriques et causer un court-circuit ou un choc électrique. Ne pas utiliser l'appareil si le cordon d'alimentation est endommagé ou a été modifié.

CAUTION

NEVER use abrasive powders or pads; these cleaners may damage the roller finish. Also, the particles may get into the drive mechanism, shortening the life of the unit.

6. Remove catch tray from unit and discard waste; clean with hot soapy water.
7. The remainder of the Roller Grill can be cleaned with a damp cloth using warm, soapy water. Warm, soapy water is recommended for cleaning; prolonged use of cleaning agents may damage stainless steel.
8. **Do not immerse in water.**
Ne jamais immerger dans l'eau.
9. Do not use a hose to clean.
10. Replace the cleaned catch tray when completely dry.

Safety

SAFETY PRECAUTIONS

Before installing and operating this equipment be sure everyone involved in its operation are fully trained and aware of all precautions. Accidents and problems can result from a failure to follow fundamental rules and precautions.

- A WINCO® Approved Recommended Qualified Service Technician should carry out repairs if necessary. Do not remove any components or service panels on this product.
- Allow the Roller Grill to cool down after use before dismantling for cleaning; the unit will be too hot to handle immediately after use.
- Before cleaning, switch off power and disconnect power cord from the outlet.
- **Do not immerse unit in water or use hose to clean.**
Ne jamais immerger l'appareil dans l'eau ni utilisez un jet d'eau pour le nettoyer.
- If the power cord is damaged, it must be replaced by a WINCO® Approved Recommended Qualified Service Technician in order to avoid a hazard.

Troubleshooting

If the SPECTRUM™ Commercial Hot Dog Roller Grill does not operate, please check the following before placing a service call:

ISSUE	MIGHT BE CAUSED BY	RECOMMENDED SOLUTION
The unit is not working and the indicator light is not on	Main power supply	Check main power supply
	Power switch has not been turned on	Check that unit is correctly plugged in and turned on
	Wrong operating procedure	Refer to operating instructions
	Damaged power cable	Replace damaged power cable - <i>Replacement must be done by an authorized service provider</i>
The unit is heating but the indicator light is not on	Built-in resettable fuse is tripped	Resettable fuse located at rear of unit - remove cap and push red plunger to reset
	The indicator light bulb has blown	Replace the indicator light - <i>Replacement must be done by an authorized service provider</i>
Indicator light is on but the unit is not heating	The unit has reached temperature	The unit is operating correctly
	Faulty element(s)	Replace faulty element(s) - <i>Replacement must be done by an authorized service provider</i>
Slow heat up of the roller surfaces	Faulty thermostat	Replace faulty thermostat - <i>Replacement must be done by an authorized service provider</i>
	Allow time to heat up	Refer to operating instructions
	Thermostat setting	Ensure that the thermostat is set correctly, also ensure the dial is not spinning on the thermostat shaft and at the wrong setting
Rollers are not rotating	Faulty element(s)	Replace faulty thermostat - <i>Replacement must be done by an authorized service provider</i>
	The unit is not on	Refer to operating instructions
	Motor fault	Check main power and motor connections - <i>Must be done by an authorized service provider</i>
	Chain fault	Check chain for misalignment - <i>Must be done by an authorized service provider</i>

Service and Repair

THIS EQUIPMENT MUST ONLY BE SERVICED BY AN AUTHORIZED AGENT.

NOTE

Parts protected by the manufacturer or its agent are not to be adjusted by the installer unless the installer is an authorized service agent.

If you have any questions or problems DO NOT send unit to WINCO® without first contacting our customer service department.

See "Limited Warranty" section on page 11 for details.

Exploded Views

MODELS: EHDG-5R / -7R / -11R

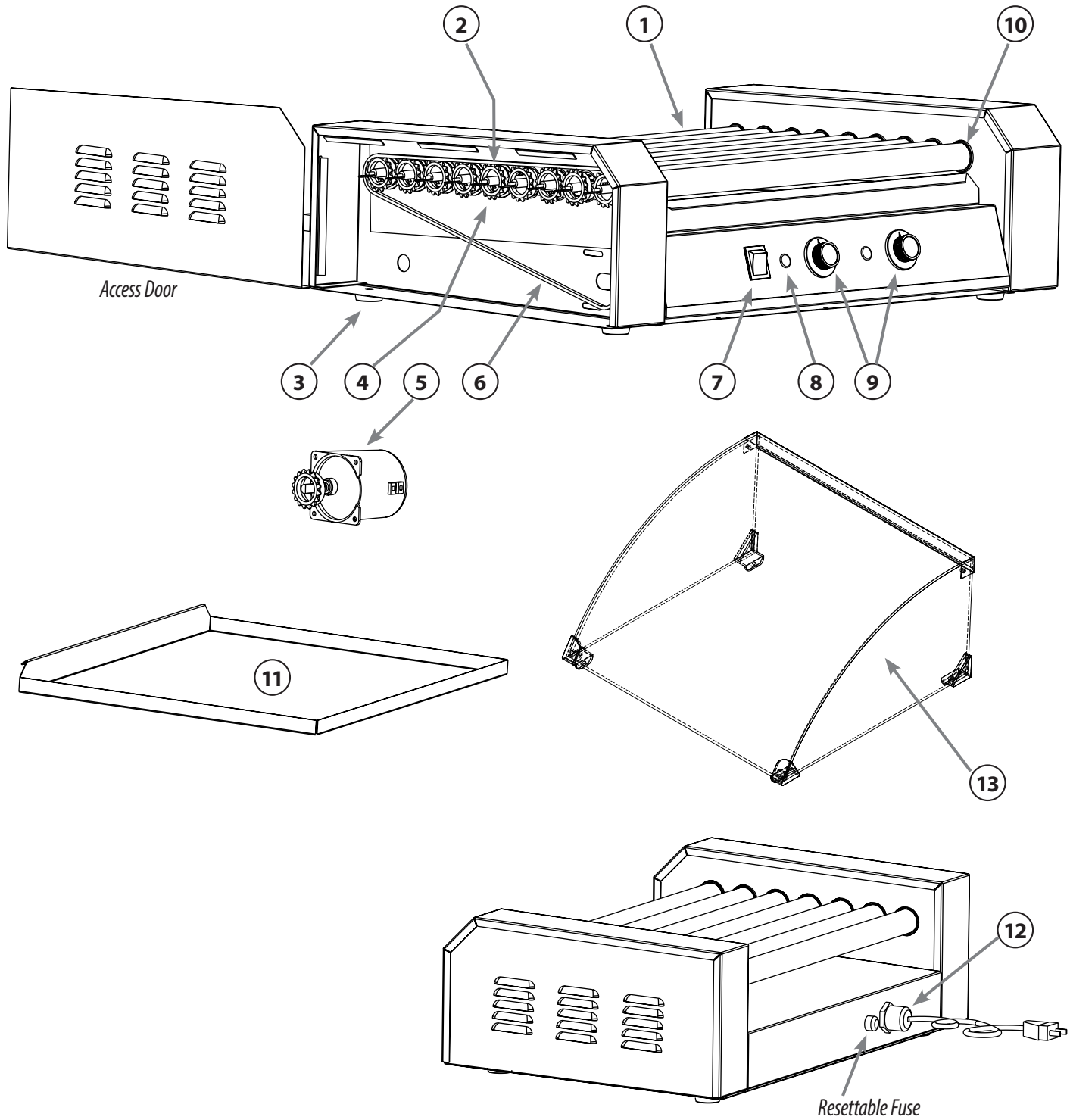

Parts List

MODELS: **EHDG-5R** / -7R / -11R

#	Description	EHDG-5R	EHDG-7R	EHDG-11R
1	Roller - Non-Stick with Teflon™ Coating	EHDG-P4	EHDG-P4	EHDG-P4
2	Gear -16 teeth	EHDG-P3	EHDG-P3	EHDG-P3
3	Rubber Foot	EHDG-P1	EHDG-P1	EHDG-P1
4	Heating Element	EHDG-P2	EHDG-P2	EHDG-P2
5	Motor	EHDG-P5	EHDG-P5	EHDG-P5
6	Chain for EHDG-5R	EHDG-P21		
	Chain for EHDG-7R		EHDG-P22	
	Chain for EHDG-11R , #1			EHDG-P25
	Chain for EHDG-11R , #2			EHDG-P26
	Grease Seal	EHDG-P7	EHDG-P7	EHDG-P7
7	Power Switch	EHDG-P11	EHDG-P11	EHDG-P11
8	Heat Indicator Light	EHDG-P8	EHDG-P8	EHDG-P8
	Thermostat	EHDG-P9	EHDG-P9	EHDG-P9
9	Knob	EHDG-P10	EHDG-P10	EHDG-P10
10	Wear-Proof O-Ring Seal	EHDG-P6	EHDG-P6	EHDG-P6
11	Drip Tray	EHDG-P27	EHDG-P28	EHDG-P30
12	Strain Relief Connector	EHDG-P12	EHDG-P12	EHDG-P12
13	Sneeze Guard Kit	EHDG-5SG	EHDG-7SG	EHDG-11SG

Please contact factory for special order parts not listed.

Electrical Circuit Diagram

MODELS: EHDG-5R / -7R / -11R

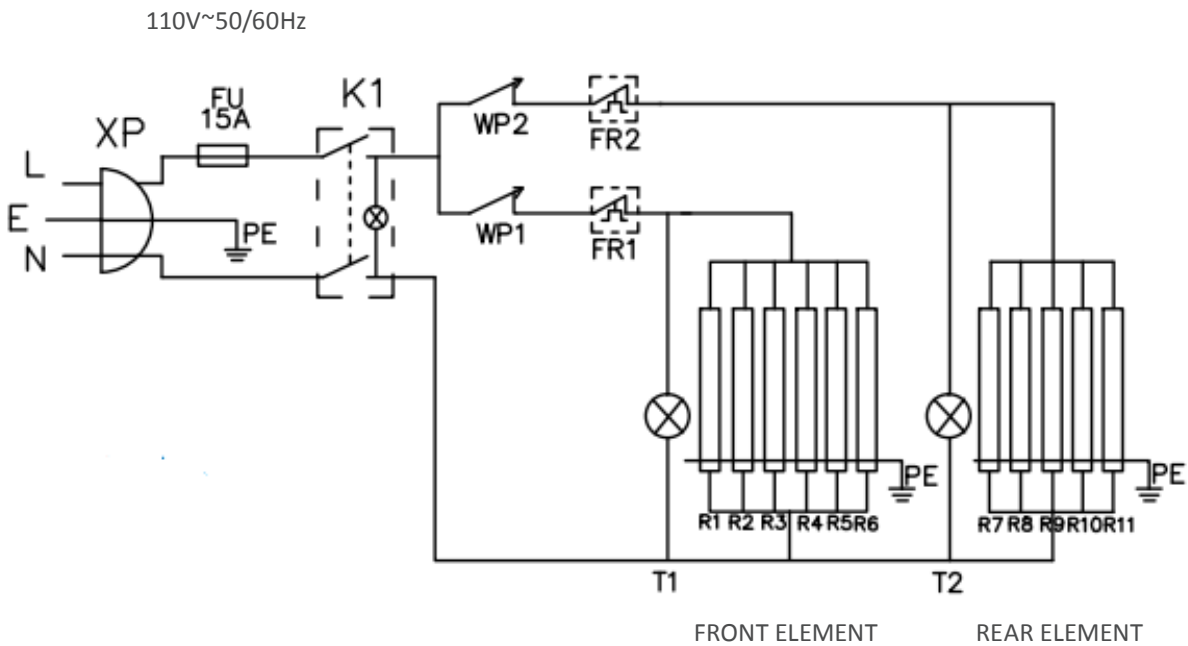

This circuit diagram has been provided to assist qualified electricians; only SPECTRUM™ service agents or qualified electricians should carry out repairs if required.

Do not remove any components or service panels on this product.

Assembly Instructions - Sneeze Guards (sold separately)

MODELS: **EHDG-5SG** / -7SG / -11SG

Sneeze guard must be assembled on top of roller grill.

a) Loosen the frame screws located on inner sides of roller grill above rollers. Use these to mount the sneeze guard brackets to the top of roller grill.

b) Slide sneeze guard side panels into front bracket and slot on rear bracket. Repeat on other side.

c) Slide the curved shield into slot on rear bracket.

d) Attach cross-brace to top of curved shield and at corners of side panels. Secure with screws and nuts provided.

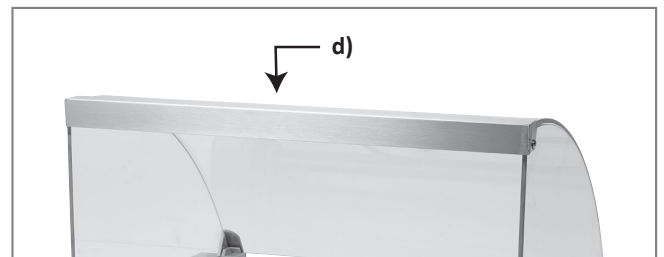
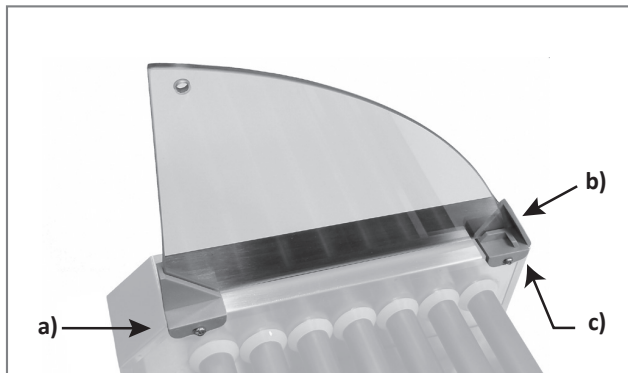

DO NOT OVERTIGHTEN SCREWS.

Overtightening causes stress points in the glass, leading to cracking/breaking.

SNEEZE GUARD ASSEMBLED ON ROLLER GRILL



- **EHDG-5SG** Fits **EHDG-5R**
- **EHDG-7SG** Fits **EHDG-7R**
- **EHDG-11SG** Fits **EHDG-11R**

EHDG-11SG sneeze guard shown on EHDG-11R roller grill

Limited Warranty

WINCO® warrants to the original purchaser of new equipment that said equipment, when installed in accordance with our instructions within North America and subjected to normal use, is free from defects in material or workmanship for a period of 1 year. The labor warranty is one year from original installation or 18 months from actual factory shipment date, whichever date occurs first.

THIS WARRANTY IS IN LIEU OF ALL OTHER WARRANTIES, WHETHER EXPRESSED OR IMPLIED. WINCO EXPRESSLY DISCLAIMS ANY IMPLIED WARRANTY OF MERCHANTABILITY OR EXPRESSED OR IMPLIED WARRANTY OF FITNESS FOR A PARTICULAR PURPOSE.

WINCO'S OBLIGATION AND LIABILITY UNDER THIS WARRANTY IS EXPRESSLY LIMITED TO REPAIRING AND REPLACING EQUIPMENT THAT PROVES TO BE DEFECTIVE IN MATERIAL OR WORKMANSHIP WITHIN THE APPLICABLE WARRANTY PERIOD.

IN NO EVENT SHALL WINCO BE LIABLE FOR INCIDENTAL OR CONSEQUENTIAL DAMAGES TO BUYER OR ANY THIRD PARTY, INCLUDING, WITHOUT LIMITATION, LOSS OF PROPERTY, PERSONAL INJURY, LOSS OF BUSINESS OR PROFITS OR OTHER ECONOMIC LOSSES, OR STATUTORY OR EXEMPLARY DAMAGES, WHETHER IN NEGLIGENCE, WARRANTY, STRICT LIABILITY, OR OTHERWISE.

This warranty is given only to the first purchaser from a retail dealer. No warranty is given to subsequent transferees.

Warranty does not cover product failures caused by: failure to maintain, neglect, abuse, damage due to excess water, fire, normal wear, improper set up and use. Periodic maintenance is not covered.

This warranty is not in force until such time as a properly completed and digitally signed Installation/Warranty Registration has been received by WINCO within 30 days from the date of installation.

WARRANTY SERVICE

To initiate warranty service contact: EquipService@winco.us or call: 973-295-3899

DO NOT send unit to WINCO® without first contacting our customer service department.

REGISTER ONLINE AT:

<http://support.winco.us>

Proof of purchase is required to extend warranty more than 1 year from date of shipment from the factory.

THE FOREGOING WARRANTY PROVISIONS ARE A COMPLETE AND EXCLUSIVE STATEMENT BETWEEN THE BUYER AND SELLER. WINCO® NEITHER ASSUMES NOR AUTHORIZES ANY PERSONS TO ASSUME FOR IT ANY OTHER OBLIGATION OR LIABILITY IN CONNECTION WITH SAID EQUIPMENT.

Examples of items not covered under warranty, but not limited to just these items:

1. Natural disasters (ie: earthquakes, tornadoes, hurricanes, etc.), fire, water damage, burglary, accident, theft.
2. Freight damage.
3. Improper installation or alteration of equipment.
4. Use of generic or after-market parts.
5. Repairs made by anyone other than a WINCO® designated service provider.
6. Lubrication.
7. Expendable wear parts, adjustable feet, blown fuses, lamps, etc.
8. Cleaning of equipment.
9. Misuse or abuse.

Please keep this manual in a safe place for future use!

Models: [EHDG-5R](#) / [EHDG-7R](#) / [EHDG-11R](#)

www.winco.us