



COMMERCIAL PANINI / SANDWICH GRILL

Operating Instruction Manual



EPG-1

Panini/Ribbed Plates



EPG-2



ESG-1

Sandwich/Flat Plates



ESG-2

Model	Description - Electric Grills	Grill Plates	Voltage ~ Hz	kW	Amperage	Grill Surface
EPG-1	Single Panini Grill	(1) Ribbed	120V ~ 60Hz	1.75	15A*	(1) 14"W x 12"D
EPG-2	Double Panini Grill	(2) Ribbed			30A** (15A per grill)	(2) 9"W x 12"D
ESG-1	Single Sandwich Grill	(1) Flat			15A*	(1) 14"W x 12"D
ESG-2	Double Sandwich Grill	(2) Flat			30A** (15A per grill)	(2) 9"W x 12"D

* One (1) dedicated 20 Amp circuit with a single outlet is required for each grill head.

** Two separate dedicated 20 Amp circuits with a single outlet for each grill head is required.

BEFORE OPERATING ANY EQUIPMENT, READ AND FAMILIARIZE YOURSELF WITH THESE USE AND SAFETY INSTRUCTIONS

Congratulations on your purchase of this WINCO® commercial equipment. WINCO takes pride in the quality of its products. When used as intended and with proper care and maintenance, you will experience years of reliable operation from this equipment. To ensure best results, it is important that you read and follow the instructions in this manual carefully. **It's important to save these instructions for future reference.**

Commercial Panini / Sandwich Grill

Package Contents	2
Unpacking the Equipment	3
Function and Purpose	3
Warning Labels	3
Installation Guidelines	4
Safety Precautions.....	4
Features and Controls	6
Operation.....	8
Cleaning the Unit.....	9
Troubleshooting	10
Wiring Diagram.....	11
Warranty.....	12

Package Contents

All units come with an Operating Instruction Manual and the following as noted:

EPG-1

- EPG-1 unit
- Removable catch tray

EPG-2

- EPG-2 unit
- Removable catch tray

ESG-1

- ESG-1 unit
- Removable catch tray

ESG-2

- ESG-2 unit
- Removable catch tray

Commercial Panini / Sandwich Grill

To ensure safe installation and operation, please carefully read and understand the following statements.

Unless the operator is adequately trained and supervised there is a possibility of injury. Owners of this equipment are responsible to make certain that this equipment is used properly and safely, and that all of the instructions contained in this manual are followed. Adherence to the requirements of local, state or federal law is required.

Owners should not permit anyone to use this equipment unless they are over 18 years old, adequately trained, supervised, and have read and understood this manual.

Owners should also ensure that no customers, visitors or other unauthorized personnel come in contact with this equipment. It is the responsibility of the owner and the operator to remain alert to any hazards posed by the function of this equipment.

If an operator is ever uncertain about a particular task or the proper method of using this equipment, they should ask an experienced supervisor.

Unpacking the Equipment

DISPOSE OF ALL PACKAGING MATERIALS IN AN ENVIRONMENTALLY RESPONSIBLE MANNER.

1. Remove all packing materials and tape, as well as any protective plastic and cardboard, from the unit.
2. Clean any glue residue left over from the plastic or tape.
3. Place the unit in the desired position and height.

SAVE THE ORIGINAL BOX AND PACKAGING FOR USE IN PACKAGING AND SHIPPING THE EQUIPMENT IF SERVICES ARE NEEDED.

Function and Purpose

This unit is intended to be used for grilling in commercial food-service operations only. It is not intended for household, industrial or laboratory use.

Before using this equipment all surfaces should be cleaned and **dried thoroughly** (see "Cleaning" section on page 9). Failure to clean surfaces before using the unit could cause food contamination.

This unit is a medium duty appliance capable of a wide variety of grilling applications.

Warning Labels

This manual contains a number of precautions to follow to help promote safe use of this equipment. Throughout the manual you will see additional warnings to help alert you to potential hazards.

Warnings affecting your personal safety are indicated by:



WARNING



CAUTION



 CAUTION Hot surface. Do not touch. Disconnect power supply and allow surface to cool before servicing.		 ATTENTION Surface chaude. Ne pas toucher. La puissance de déconnexion électrique et laisser refroidir la surface avant l'entretien.
------------------------------------------------------------------------------------------------------------------------------------------	--	-----------------------------------------------------------------------------------------------------------------------------------------------------------------------

Warnings related to possible damage to equipment are indicated by:



WARNING



CAUTION



NOTE

Note is used to notify users of installation, operation, or maintenance information that is important but not hazard-related.

Please remember that this manual and the warning labels do not replace the need to be alert, to properly train and supervise operators, and to use common sense when using this equipment.

Installation Guidelines

These precautions should be followed at all times. Failure to follow these precautions could result in injury to yourself and others.

TO REDUCE RISK OF INJURY OR DAMAGE TO THE UNIT:

1. Read this manual thoroughly before installation and operation. DO NOT proceed with installation and operation if you have any questions or do not understand anything in this manual. Contact your representative or the manufacturer first.
2. Remove the grill from the box. Once your grill has been removed from the packaging, be certain that all protective plastics and residues are removed from all surfaces.
3. Select a location for the grill that has a level, solid, non-skid surface that is nonflammable and away from water hazards or sinks, and is in a well-lit ventilated work area away from children and visitors.
4. Inspect the grill to ensure all parts have been provided.

NOTE

Local codes regarding installation vary greatly by area. The National Fire Protection Association, Inc, states in its NFPA 96 latest edition that local codes are "authority having jurisdiction" when it comes to requirements for installation of equipment. Therefore, installation should comply with all local codes.

5. The installation of the grill must conform to the NATIONAL ELECTRIC CODE AND ALL LOCAL ELECTRIC CODES AND ORDINANCES AND ALL THE LOCAL ELECTRICAL COMPANY RULES AND REGULATIONS. Additionally, we recommend that the grill is allowed a 4" spacing surrounding the unit in order to provide adequate ventilation.
6. Model EPG-1, EPG-2, ESG-1 and ESG-2 ---- 120V
These panini/sandwich grills are wired to be used with a standard 120V/AC receptacle and may be plugged in any convenient outlet. This unit requires 15 amps to produce 1800 watts and should be used on a dedicated circuit.
7. Proper connections and power supply are essential for efficient performance.



WARNING

These electric panini/sandwich grills are equipped for the voltage indicated on the nameplate mounted on the rear of the unit. The panini/sandwich grill is designed for use on alternating current (AC) only.

8. Any external wiring should be in a conduit or an approved type of flexible cable suitable for operation at temperature indicated at the conduit hole, and in a proper size to carry the load.
9. The supply circuit should be properly fused and equipped with a means of disconnecting, as required by the local electrical code. For a grill with plugs and leads set, simply provide a suitable power outlet and connect.
10. CAUTION: Use supply wire suitable for 167°F (75°C)
11. CAUTION: A suitable grease-collecting means must be in place before operating appliance.
12. Use copper aluminum wire for power supply connections.



CAUTION

This equipment gets EXTREMELY HOT so make sure all flammable/combustible materials are set away from this equipment.

Safety Precautions

This unit is intended to be used in commercial food-service operations only. It is not intended for household, industrial or laboratory use.

Before using this equipment it must be cleaned and **dried thoroughly**. Clean all surfaces before use. Failure to clean surfaces before using the unit could cause food contamination.

Proper Grounding

This machine is provided with a three-pronged grounding plug. The outlet to which this plug is connected must be properly grounded. If the receptacle is not the proper grounding type, contact an electrician. DO NOT, under any circumstances, cut or remove the third ground prong from the power cord or use any adaptor plug.



CAUTION	⚠ WARNING
 HOT	Burn Hazard. The grill plate surfaces and outside covering/containment unit may become HOT after use.
USE CAUTION WHEN TOUCHING THE UNIT.	

TO AVOID SERIOUS PERSONAL INJURY

- DO NOT** operate the grill before reading the instruction manual first.
- ALWAYS** disconnect or unplug electrical power before cleaning, servicing or adjusting any parts or attachments.
- NEVER** bypass, alter or modify this equipment in any way from its original condition. Doing so may create hazards and will void warranty.
- NEVER** operate the grill with a damaged power cord or plug.
- NEVER** leave the grill on overnight.
- NEVER** use grill as a heating source for your kitchen, space, or room.
- ALWAYS** keep hands, hair and clothing away from heating plates.



CAUTION

IMPORTANT SAFEGUARDS & SAFETY INSTRUCTIONS
When using electrical food equipment, basic safety precautions should always be followed. INCLUDING THE FOLLOWING:

- DO NOT** touch hot surfaces. Use handles or knobs.
- CAUTION:** To protect against risk of electrical shock, do not immerse in water, dishwasher or any other liquid.

	⚠ WARNING
	Electrical Shock Hazard. Keep water and other liquids from entering the inside of the unit. Liquid inside the unit could cause an electrical shock.
Do not spray water or cleaning products. Liquid could contact the electrical components and cause a short circuit or an electrical shock. Do not use unit if power cord is damaged or has been modified.	

- NEVER** touch the heating plates while the grill is on.
- ALWAYS** unplug unit when not in use, before putting on or taking off parts, and before cleaning.
- DO NOT** operate any equipment with a damaged cord or plug or after the appliance malfunctions or is dropped or damaged in any manner. Call for service.
- CAUTION:** The use of attachments not recommended or sold by the manufacturer may cause fire, electrical shock or injury.
- DO NOT** use outdoors.

- DO NOT** let power cord or the extension cord hang over edge of table or counter or to touch hot surfaces.
- DO NOT** place on or near a hot gas or electric burner, or in a heated oven.
- DO NOT** use this equipment for any use other than the use intended by the manufacturer.
- DO NOT** pull by the cord to disconnect.
- NEVER** plug equipment in where water floods the area.
- ALWAYS** place the appliance on a firm, stable surface.

CAUTION	⚠ WARNING
 HOT	Burn Hazard. The grill plate surfaces and outside covering/containment unit may become HOT after use.
USE CAUTION WHEN TOUCHING THE UNIT.	

- CAUTION:** During operation the grill reaches high temperatures, in turn, heating any stainless steel surfaces. Take extreme care when operating. Only handle the grill by its' handles to eliminate accidents.
- ALWAYS** switch off the power and unplug the unit for cleaning.
- ALWAYS** allow the grill to cool down to room temperature after use and before dismantling for cleaning; the unit will be too hot to handle immediately after use.
- CAUTION:** A SUITABLE GREASE-COLLECTING MEANS MUST BE IN PLACE BEFORE OPERATING APPLIANCE.

WARNING for EPG-2 and EFG-2 ONLY

CAUTION – This product has two power supply cords. Connect each plug to a receptacle that is connected to an individual branch circuit. Unplug both cords before moving or servicing this appliance.

CAUTION – This unit has more than one disconnect switch

CAUTION – Individual branch circuits are to be employed to supply the product and indicate what actions are required for a proper installation.

ATTENTION UNIQUEMENT POUR EPG-2 et EFG-2

ATTENTION: UN NOYEAU D'AMAS DE GRAISSE CONFONABLE DOIT ETRE PLACE AVANT D'OPERER L'APPAREIL

ATTENTION - Ce produit dispose de deux cordons d'alimentation. Connecter chaque fiche à une prise qui est connectée à un circuit indépendant. Débranchez les deux câbles avant de déplacer ou de réparer cet appareil.

ATTENTION - Cet appareil a plus d'un sectionneur.

ATTENTION - circuits de dérivation individuels doivent être utilisés pour fournir le produit et indiquer quelles actions sont nécessaires pour une installation correcte.

Features and Controls: EPG-1, EPG-2 Panini Grills



Figure 1. Features and Controls of EPG-1 & EPG-2



Figure 2. Removable catch tray

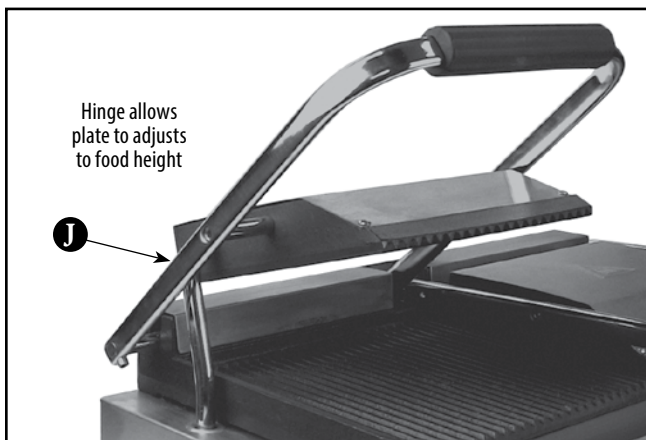

Figure 3. Hinged top plate

- A UPPER GRILL HANDLE BAR** (Figure 1) Used to lower and raise the grill plate(s).
- B THERMOSTAT CONTROL DIALS** (Figure 1) Used to set or adjust the temperature of the corresponding right or left side of grill plate. The numbers on the dial correspond with the grill plate temperature. The "0" position is off.
- C POWER ON/OFF SWITCHES** (Figure 1) Separate switches turns power to the unit on/off for corresponding left or right side.
- D TEMPERATURE READY LIGHTS** (Figure 1) This light indicates that the element is heating. Once the temperature has been reached the light will go out. Unit will continue to maintain heat and temperature with light cycling on and off. **This is not an "ON/OFF" light.**
- E BOTTOM (RIBBED) GRILL PLATE** (Figure 1)
- F TOP (RIBBED) GRILL PLATE** (Figure 4)
- G REMOVABLE CATCH TRAY** (Figure 2) Catches grease / crumbs
- H SIDE VENTS** (Figure 1)
- I FEET** (Figure 1)
- J HINGE** (Figure 3) Allows plate to adjust to the height of the food being grilled.

Features and Controls: ESG-1, ESG-2 Sandwich Grills



Figure 4. Features and Controls of ESG-1 & ESG-2

- A UPPER GRILL HANDLE BAR** (Figure 4) Used to lower and raise the grill plate(s)
- B THERMOSTAT CONTROL DIALS** (Figure 4) Used to set or adjust the temperature of the corresponding right or left side of grill plate. The numbers on the dial correspond with the grill plate temperature. The "0" position is off.
- C POWER ON/OFF SWITCHES** (Figure 4) Separate switches turns power to the unit on/off for corresponding left or right side..
- D TEMPERATURE READY LIGHTS** (Figure 4) This light indicates that the element is heating. Once the temperature has been reached the light will go out. Unit will continue to maintain heat and temperature with light cycling on and off. **This is not an "ON/OFF" light.**
- E BOTTOM (FLAT) GRILL PLATE** (Figure 4)
- F TOP (FLAT) GRILL PLATE** (Figure 4)
- G REMOVABLE CATCH TRAY** (Figure 5) Catches grease / crumbs
- H SIDE VENTS** (Figure 4)
- I FEET** (Figure 4)
- J HINGE** (Figure 6) Allows plate to adjust to the height of the food being grilled.



Figure 5. Removable catch tray



Figure 6. Hinged top plate

Operation

BEFORE OPERATING GRILL, IT SHOULD BE CHECKED TO SEE THAT IT IS SITTING LEVEL. BE SURE THE CATCH TRAY HAS BEEN PROPERLY PLACED.

Follow these same instructions for each grill of a two grill unit. Each grill operates independently and may be operated at different temperatures.

Both the EPG-2 and ESG-2 require the use of two cords. Be sure to unplug both cords prior to moving, testing or repairing this product.

Using a soft cloth, wipe away any oil that is covering the grill plates. This is only to protect parts during shipping. Turn heat to high to burn off the remaining oil.

ALLOW APPROXIMATELY 30 MINUTES FOR GRILLING PLATES TO HEAT UP.

Once the excess oil is burned away, use a grill stone or stainless steel brush to remove the burnt oil.

NOTE

Upon first use, grill may omit a metallic burning odor. This is normal and the odor will regress with use.

Season the Surface

All panini/sandwich grills have a cast iron cooking surface.

Clean the cooking surface thoroughly. After the cooking surface has been thoroughly cleaned, it should be seasoned with vegetable oil to prevent food from sticking. Before each use, and after each use, thoroughly clean and season the cooking surface by heating the surface in the following manner:

1. Turn the ON/OFF switch to the "ON" position and adjust the Temperature Control Dial (B) halfway between the 300° F and 400° F marks.



CAUTION

The grill surface will be HOT!

2. Using a clean cloth, not a spatula, spread a thin film of vegetable oil over the grill cooking surface. This film should remain on the hot grill for 30 minutes.
3. Carefully remove the excess oil and wipe clean.
4. Repeat steps 2 and 3.



CAUTION

The grill surface will be HOT!

THE GRILL SURFACE IS NOW READY FOR USE.

EVEN WITH PROPER SEASONING, FOOD MAY STICK TO THE GRILL COOKING SURFACE UNTIL THE GRILL PLATE IS "BROKEN IN". USE A MEDIUM-HARD STAINLESS STEEL BRUSH TO REMOVE REMAINING FOOD PIECES.

COOKING

1. Turn the Power ON/OFF Switch (C) to the "ON" position.
2. Set the Thermostat Control Dial (B) at the desired temperature.
3. Temperature Ready Light (D) will remain on while heating to desired temperature.
4. When the desired temperature is reached, the Temperature Ready Light (D) will go off.
5. Using the Upper Grill Handle Bar (A), raise the top of the grill to expose the top of the grill plate.
6. Place the food product onto the grill. Using the Upper Grill Handle Bar (A), lower the Top Grill Plate (F) down onto the food product.
7. Grill to required doneness.
8. Raise the Top Grill Plate (F) using the Upper Grill Handle Bar (A) and remove the food item. Prepare as desired.
9. After each time the grill is loaded, it is recommended that excess grease and food particles are pushed into the Catch Tray (G) using a nylon bristle brush or coarse rag (DO NOT use steel bristle brush). If necessary, empty the grease from the Catch Tray (G) before you resume grilling.

USDA® Recommended Internal Temperatures

Food	°F
Ground Meat and Meat Mixtures	
Beef, Pork, Veal, Lamb	160
Turkey, Chicken	165
Fresh Beef, Veal, Lamb	
Medium Rare	145
Medium	165
Well Done	170
Poultry	
Chicken and Turkey, whole	165
Poultry breasts, roasts	165
Poultry thighs, wings	165
Duck and Goose	165
Stuffing (cooked alone or in bird)	165
Fresh Pork	160
Ham	
Fresh (raw)	160
Pre-cooked (to reheat)	140
Eggs and Egg Dishes	
Eggs	Cook until yolk & white are firm
Egg dishes	160

CAUTION

The grill surface and grease will be HOT!

Cleaning Instructions

1. **ALWAYS** unplug the grill before cleaning
2. **DO NOT** use any cleaning fluids that can be harmful to humans.
3. **DO NOT** hose down, immerse or pressure wash any part of the grill, excluding the catch tray.
4. **NEVER** use a scrubber pad, steel wool or abrasive material to clean the grill.
5. **NEVER** spray any type of cleaning solution directly onto unit. Spray on soft cloth and wipe unit clean.

Always disconnect or unplug the electrical power from the grill before cleaning.

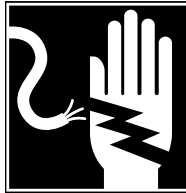

WARNING

Electrical Shock Hazard.

Keep water and other liquids from entering the inside of the unit. Liquid inside the unit could cause an electrical shock.

Do not spray water or cleaning products. Liquid could contact the electrical components and cause a short circuit or an electrical shock. Do not use unit if power cord is damaged or has been modified.

RECOMMENDED CLEANING

It takes very little time and effort to keep the grill clean and performing at top efficiency. If grease is permitted to accumulate, it will form a gummy cake and then carbonize into a hard substance that is extremely difficult to remove. To prevent this condition, please follow the cleaning steps below:

PART	REQUIRED ACTION	FREQUENCY
Cast Iron Plates	Scrape the grill with a scraper or flexible spatula to remove excess oil/fat and food. A catch tray is provided for the scrapping. If there is an accumulation of burned fats and food, the grill should be thoroughly scoured and re-seasoned. Use pumice or grill stone, while the grill is warm, to remove excess fat and food. Do not use steel wool because of the danger of steel slivers getting into the food.	After Each Use
Body	Use a clean cloth and a non-abrasive cleaner to clean the stainless steel body of the grill. Wipe the polished areas with a soft cloth. Avoid spraying any cleaner into the controls or switches of the unit.	Daily
Controls	Unit should be turned off when not in use. It is recommended that the unit also be unplugged. Use a clean cloth to wipe down any controls and/or knobs	Daily
Catch Tray	Once the unit has cooled, remove the catch tray and discard the waste, debris and crumbs. CAUTION: If the catch tray is permitted to fill too high, the excess grease will run out of the overflow hole at the front of it. The catch tray/drawer is removed by pulling forward. USE CAUTION WHEN FILLED WITH HOT GREASE! The catch tray is dishwasher safe.	Per Use or at least Daily

Troubleshooting

PROBLEM	MIGHT BE CAUSED BY	COURSE OF ACTION
Grill not working	Power supply	Check power source
	Power switch has not been turned on	Check that the unit is properly plugged in and turned on
	Plug/cord, set or external wiring is damaged	Contact Winco® Customer Service
	Internal wiring fault	Contact Winco® Customer Service
Indicator light is on, but unit is NOT heating up	Faulty elements	Contact Winco® Customer Service
	Operation of thermostat All thermostats are not turned on	Ensure thermostat is set correctly and that the temperature select knob is firmly secured to the thermostat shaft (not spinning independently)
	Faulty thermostat	Contact Winco® Customer Service
Indicator light is not on, but the unit IS heating up	The indicator bulb has burned out	Contact Winco® Customer Service
Cooking surface is heating up too slowly	Carbon build up	Ensure that the plates are kept clean and free from carbon build up / debris (see "Cleaning" section on page 9)
	Thermostat setting	Ensure thermostat is set correctly and that the temperature selection knob is firmly secured to the thermostat shaft (not spinning independently)
	Faulty elements	Contact Winco® Customer Service
Food sticking	Carbon build up	Ensure that the plates are kept clean and free from carbon build up/debris (see "Cleaning" section on page 9)
	Not seasoned	Season grill (see "Operation" page 8)

Safety

A WINCO® Approved Service Technician should carry out repairs if necessary. Do not remove any components or service panels on this product.

If the power cord is damaged, it must be replaced by a WINCO Approved Service Technician in order to avoid a hazard.

Wiring Diagram

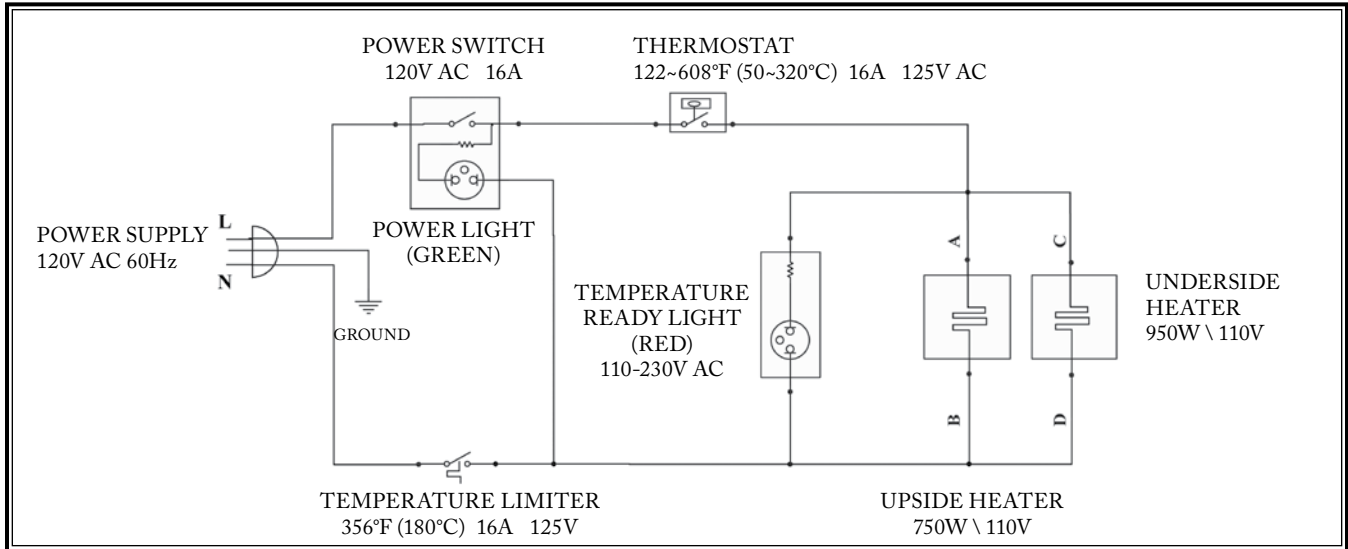

EPG-2 and ESG-2 have 4 circuits (2 sets of top and bottom heated plates)
 EPG-1 and ESG-1 have 2 circuits (1 top and one bottom heated plates)

Service and Repair

There are no user serviceable parts within this appliance. To avoid serious injury or damage, **NEVER** attempt to repair the unit yourself.

To initiate warranty service contact: support@wincous.com or call: **973-295-3899**.

DO NOT send unit to WINCO without first contacting our customer service department.

See "Limited Warranty" section on page 12 for details.

Limited Warranty

WINCO® warrants to the original purchaser of new equipment that said equipment, when installed in accordance with our instructions within North America and subjected to normal use, is free from defects in material or workmanship for a period of 1 year. The labor warranty is one year from original installation or 18 months from actual factory shipment date, whichever date occurs first.

THIS WARRANTY IS IN LIEU OF ALL OTHER WARRANTIES, WHETHER EXPRESSED OR IMPLIED. WINCO EXPRESSLY DISCLAIMS ANY IMPLIED WARRANTY OF MERCHANTABILITY OR EXPRESSED OR IMPLIED WARRANTY OF FITNESS FOR A PARTICULAR PURPOSE.

WINCO'S OBLIGATION AND LIABILITY UNDER THIS WARRANTY IS EXPRESSLY LIMITED TO REPAIRING AND REPLACING EQUIPMENT THAT PROVES TO BE DEFECTIVE IN MATERIAL OR WORKMANSHIP WITHIN THE APPLICABLE WARRANTY PERIOD.

IN NO EVENT SHALL WINCO BE LIABLE FOR INCIDENTAL OR CONSEQUENTIAL DAMAGES TO BUYER OR ANY THIRD PARTY, INCLUDING, WITHOUT LIMITATION, LOSS OF PROPERTY, PERSONAL INJURY, LOSS OF BUSINESS OR PROFITS OR OTHER ECONOMIC LOSSES, OR STATUTORY OR EXEMPLARY DAMAGES, WHETHER IN NEGLIGENCE, WARRANTY, STRICT LIABILITY, OR OTHERWISE.

This warranty is given only to the first purchaser from a retail dealer. No warranty is given to subsequent transferees.

Warranty does not cover product failures caused by: failure to maintain, neglect, abuse, damage due to excess water, fire, normal wear, improper set up and use. Periodic maintenance is not covered.

This warranty is not in force until such time as a properly completed and digitally signed Installation/Warranty Registration has been received by WINCO within 30 days from the date of installation.

WARRANTY SERVICE

To initiate warranty service contact: support@wincous.com
or call: 973-295-3899

DO NOT send unit to WINCO without first contacting our customer service department.

REGISTER ONLINE AT:

<http://support.wincous.com>

Proof of purchase is required to extend warranty more than 1 year from date of shipment from the factory.

THE FOREGOING WARRANTY PROVISIONS ARE A COMPLETE AND EXCLUSIVE STATEMENT BETWEEN THE BUYER AND SELLER. WINCO NEITHER ASSUMES NOR AUTHORIZES ANY PERSONS TO ASSUME FOR IT ANY OTHER OBLIGATION OR LIABILITY IN CONNECTION WITH SAID EQUIPMENT.

Examples of items not covered under warranty, but not limited to just these items:

1. Acts of God, fire, water damage, burglary, accident, theft.
2. Freight damage.
3. Improper installation or alteration of equipment.
4. Use of generic or aftermarket parts.
5. Repairs made by anyone other than a WINCO designated service provider.
6. Lubrication.
7. Expendable wear parts, adjustable feet, blown fuses, lamps, etc.
8. Cleaning of equipment.
9. Misuse or abuse.

WARRANTY REGISTRATION

SCAN THE QR CODE WITH YOUR MOBILE DEVICE

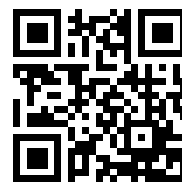

or go to

<http://support.wincous.com>

TO FILL OUT AND SUBMIT YOUR WARRANTY REGISTRATION.

Please keep this manual in a safe place for future reference.