

**KATTEX** by **winco**<sup>®</sup>  
www.wincous.com

## FRUIT WEDGER SLICER

**FWS-6**

**FWS-8**



### Warranty Service

To initiate warranty service contact:  
[equipservice@wincous.com](mailto:equipservice@wincous.com) or call: 973-295-3899

**DO NOT** send unit to WINCO without first contacting  
our customer service department.

# INTRODUCTION

**Congratulations on the purchase of your KATTEX machine. Please take the time to carefully read through this manual to ensure the machine is operated and maintained properly, to ensure the best possible performance from this product for many years.**

**WINCO will not accept liability if:**

- The instructions in this manual have not been followed correctly.
- Non-authorized personnel have tampered with the machine.
- Non-original spare parts are used.
- The machine has not been handled and cleaned correctly.
- There is any use damage to the unit.

## SAFETY



**WARNING: THE BLADES ARE VERY SHARP. PLEASE USE CAUTION WHEN HANDLING AND OPERATING THE MACHINE AND KEEP HANDS AWAY FROM ALL CUTTING EDGES.**



**AVERTISSEMENT: TRÈS COUPANTES TRÈS COUPANTES. VEUILLEZ FAIRE PREUVE DE PRUDENCE LORSQUE VOUS MANIPULEZ ET UTILISEZ LA MACHINE ET GARDEZ LES MAINS ÉLOIGNÉES DE TOUS LES BORDS DE COUPE.**



**WARNING: IMPROPER INSTALLATION, ADJUSTMENT, ALTERATION, SERVICE OR MAINTENANCE CAN CAUSE PROPERTY DAMAGE, INJURY, OR DEATH. READ THE INSTALLATION, OPERATION, AND MAINTENANCE INSTRUCTIONS THOROUGHLY BEFORE INSTALLING OR SERVICING THIS EQUIPMENT.**



**AVERTISSEMENT: TOUTE INSTALLATION, RÉGLAGE, MODIFICATION, RÉPARATION OU ENTRETIEN INCORRECT PEUT OCCASIONNER DES DOMMAGES MATÉRIELS, DES BLESSURES GRAVES OU LA MORT. LIRE LES INTRUCTIONS D'INSTALLATION, D'UTILISATION ET D'ENTRETIEN ATTENTIVEMENT AVANT D'INSTALLER OU DE RÉPARER CET APPAREIL.**



**CAUTION: THESE MODELS ARE DESIGNED, BUILT, AND SOLD FOR COMMERCIAL USE ONLY. IF THESE MODELS ARE POSITIONED SO THE GENERAL PUBLIC CAN USE THE EQUIPMENT, MAKE SURE THAT CAUTION SIGNS, WARNINGS, AND OPERATING INSTRUCTIONS ARE CLEARLY POSTED NEAR EACH UNIT SO THAT ANYONE USING THE EQUIPMENT WILL USE IT CORRECTLY AND NOT INJURE THEMSELVES OR HARM THE EQUIPMENT.**



**ATTENTION: CES MODÈLES SONT CONÇUS, FABRIQUÉS, ET VENDUS POUR UN USAGE COMMERCIAL SEULEMENT. SI CES MODÈLES SONT PLACÉS POUR QUE LE GRAND PUBLIC PUISSE LES UTILISER, ASSUREZ-VOUS QUE LES CONSIGNES D'ATTENTION, D'AVERTISSEMENT, ET LES INSTRUCTIONS D'UTILISATION SOIENT CLAIREMENT AFFICHÉES PRÈS DE CHAQUE UNITÉ DE SORTE QUE N'IMPORTE QUEL UTILISATEUR DE L'APPAREIL L'EMPLOIE CORRECTEMENT ET NE SE BLESSE PAS OU N'ENDOMMAGE PAS L'APPAREIL.**



**WARNING: A FACTORY AUTHORIZED SERVICE PROVIDER SHOULD HANDLE ALL MAINTENANCE AND REPAIR. BEFORE DOING ANY MAINTENANCE OR REPAIR, FOLLOW SERVICE SET UP ARRANGEMENT.**



**AVERTISSEMENT: UN TECHNICIEN AUTORISÉ PAR L'USINE DEVRA EFFECTUER TOUT L'ENTRETIEN ET LES RÉPARATIONS. AVANT DE FAIRE TOUT ENTRETIEN OU RÉPARATION, VEUILLEZ CONTACTER WINCO.**

## SAFETY (CONT.)

**To ensure safe installation and operation, please carefully read and understand the following statements.**

**Unless the operator is adequately trained and supervised there is a possibility of serious injury. Owners of this equipment bear the responsibility to make certain that this equipment is used properly and safely, and to strictly follow all of the instructions contained in this manual and the requirements of local, state or federal law.**

**Owners should not permit anyone to touch this equipment unless they are over 18 years old, are adequately trained and supervised, and have read and understood this manual.**

**Owners should also ensure that no customers, visitors or other unauthorized personnel come in contact with this equipment. It is the responsibility of the owner and the operator to remain alert to any hazards posed by the function of this equipment.**

**If there is ever uncertainty about a particular task or the proper method of operating this equipment, ask an experienced supervisor.**

*Note: Please remember that this manual and the warning labels do not replace the need to be alert, to properly train and supervise operators, and to use common sense when using this equipment.*

## PACKAGE CONTENTS

**All KATTEX Fruit Wedger Slicers come with the following:**

- Assembled Fruit Wedger Slicer (FWS-6/FWS-8)
- Operating Instruction Manual

**WINCO® prides itself on quality and service, ensuring that at the time of packing, all products are supplied fully functional and free of damage. Should you find any damage as result of freight, please contact your WINCO® dealer immediately.**

## UNPACKING THE EQUIPMENT

**Dispose of all packaging materials in an environmentally responsible manner.**

1. Remove all packing materials and tape, as well as any protective plastic and cardboard from the unit.
2. Clean any glue residue left over from the plastic or tape.
3. Place the unit in the desired position and height.

**SAVE THE ORIGINAL BOX AND PACKAGING FOR USE IN PACKAGING AND SHIPPING THE EQUIPMENT IF SERVICES ARE NEEDED.**

# PREPARATION

## Changing the Blade Assembly

1. Remove push block by lifting straight up off the guide rods.
2. Remove the screws from the base and remove the blade assembly.



**WARNING: THE BLADES ARE VERY SHARP.  
PLEASE USE CAUTION WHEN HANDLING.**

3. Replace with desired blade and secure the screws into the base.
4. Slide the push block onto guide rods and gently lower the push block onto the blade assembly to ensure that the push block rests on the bumpers. If it does not, adjustments need to be made prior to beginning the cutting procedure.

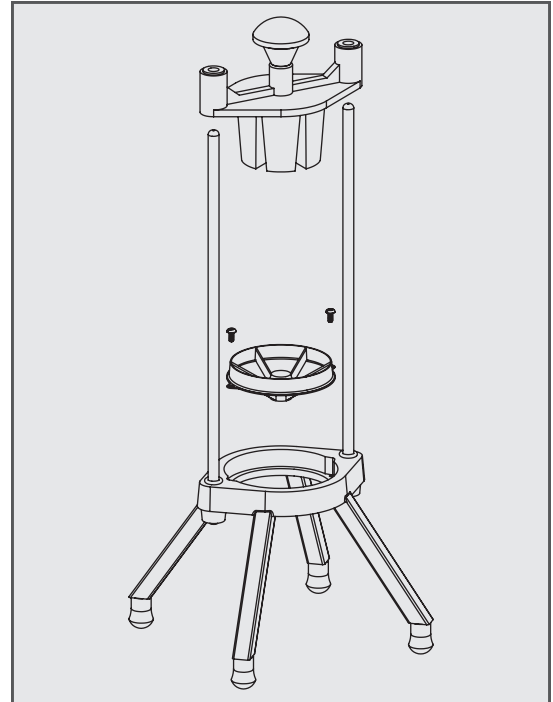

# OPERATION

Since the push block and blade assemblies for different sized cuts are interchangeable, you may have more than one set available for use. Before cutting, please ensure that the push block is the correct one to use for the desired cut size. Gently lower the push block onto the blade assembly to ensure that the push block rests on the bumpers. If it does not, adjustments need to be made prior to beginning the cutting procedure.

1. Place the fruit wedge slicer on a firm work surface or countertop.
2. Lift the handle and place the produce on the blades.



**WARNING: DO NOT ATTEMPT TO CHOP PRODUCE  
LARGER THAN THE OPENING IN THE BLADE HOLDER.**

4. Ensure that all hands and fingers are not in the cutting area. With a strong, quick thrust, bring the push block down to force the produce through the blades.
5. Clean the machine after slicing is completed in accordance with the cleaning instructions.

***If the unit fails to properly operate during its first use,  
call Winco customer service at 973-295-3899 or  
email at [equipservice@wincous.com](mailto:equipservice@wincous.com).***

***DO NOT send unit to WINCO without first contacting  
our customer service department.***

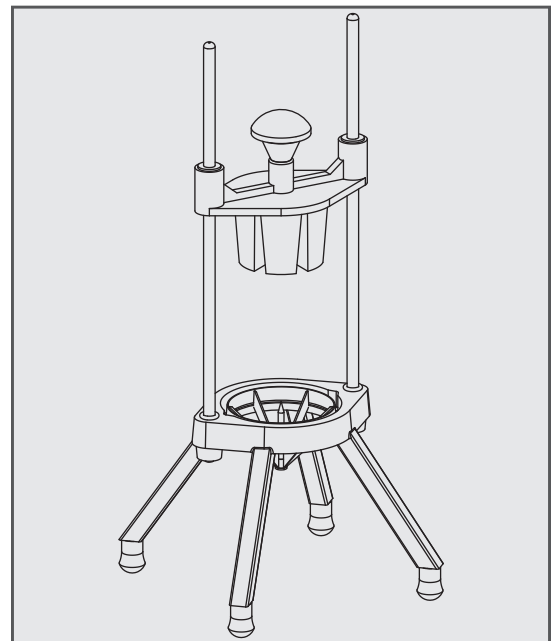

# CLEANING

Cleaning of the device is important to assuring optimal performance and longevity. Minimize the use of alkaline or acidic cleaners, as they may cause pitting and dulling of the finish.

1. Lift the handle and push block off the guide rods.
2. Remove screws from the base to release the blade assembly.



**WARNING: THE BLADES ARE VERY SHARP. PLEASE USE CAUTION WHEN HANDLING.**

3. Thoroughly wash/rinse/sanitize parts in warm soapy water, dry and carefully reassemble.

*Note: Hand washing unit is recommended as washing in a commercial dishwasher will cause the all aluminum parts to darken over time, this is normal, and does not effect the general operation of the unit.*

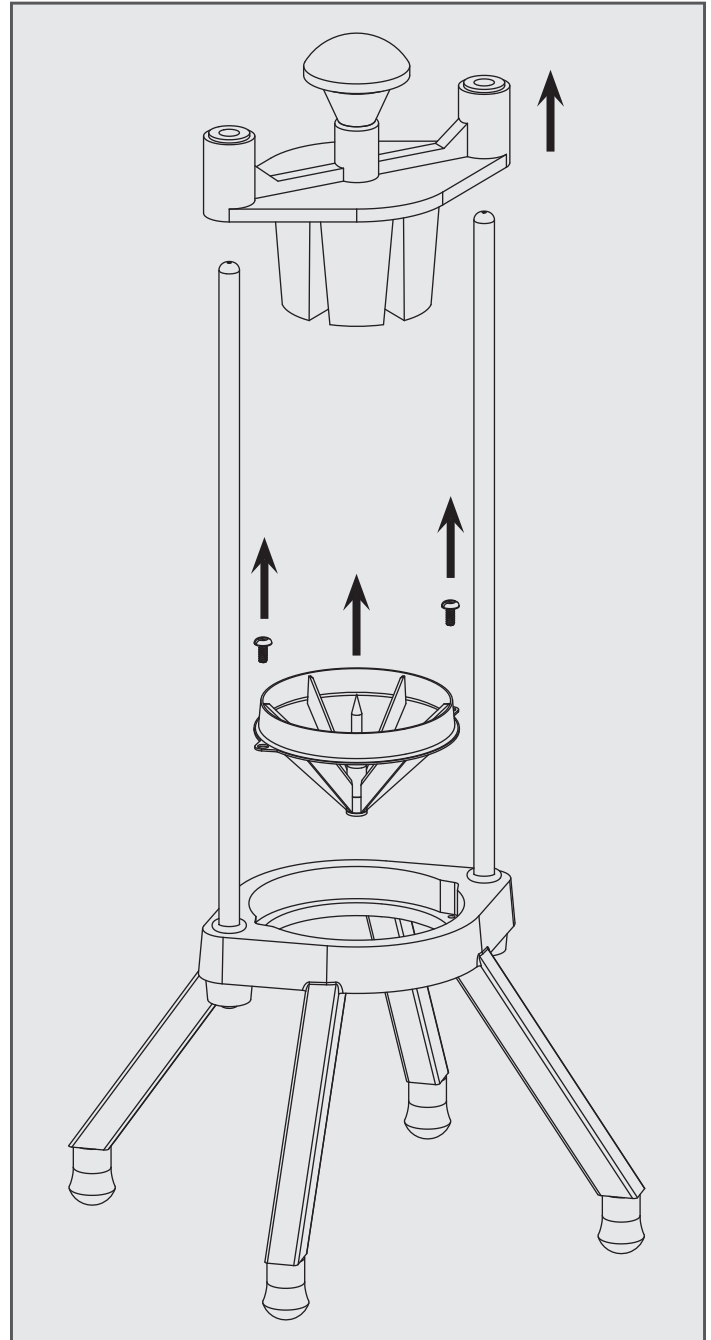

# MAINTENANCE

As needed, lubricate the guide rods with mineral oil, food grade grease, or rub them with Paraffin. Do not lubricate with cooking oil.

# PARTS LIST

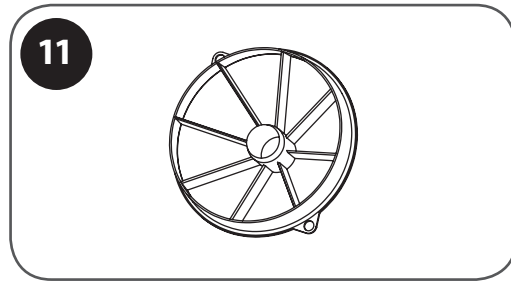
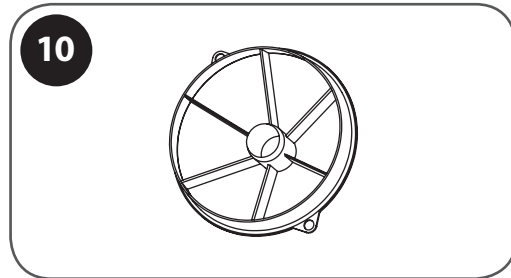
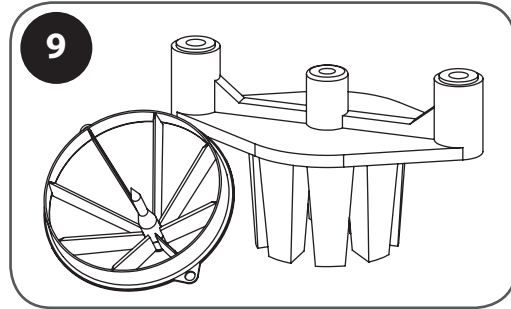
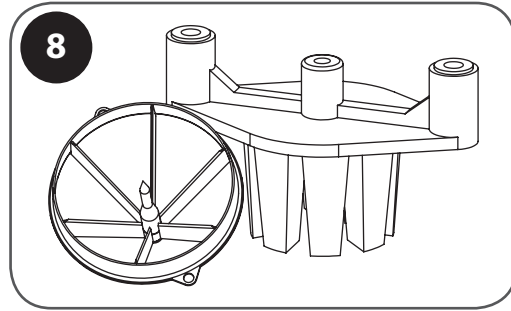
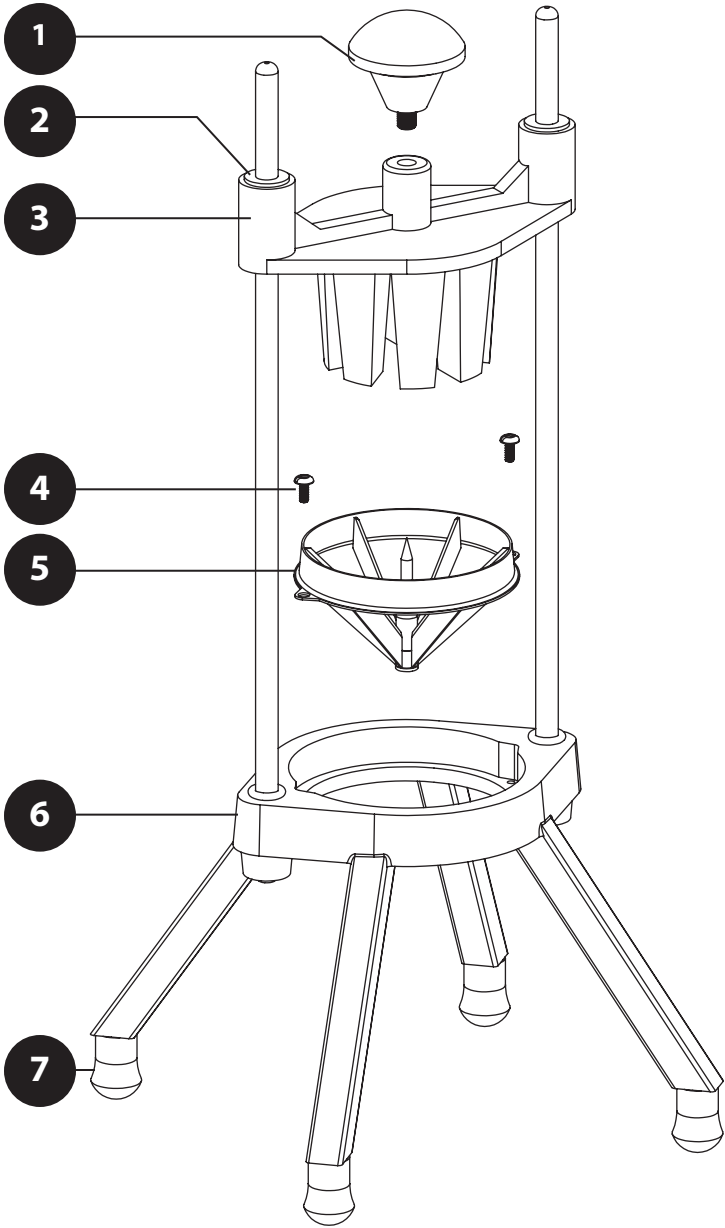

No.	Description	Part #	QTY
1	Knob		1
2	Plastic Bushing	<a href="#">KAT-BS-FH</a>	4
3	Wedger Push Block		1
4	Blade Screws		2
5	Blade Assembly		1
6	Base		1
7	Rubber Foot	<a href="#">KAT-FT</a>	4
8	6-Section Wedger & Blade Assembly	<a href="#">FWS-6BK</a>	1
9	8-Section Wedger & Blade Assembly	<a href="#">FWS-8BK</a>	1
10	6-Section Apple Corer Blade	<a href="#">FWS-6BC</a>	1
11	8-Section Apple Corer Blade	<a href="#">FWS-8BC</a>	1

# WARRANTY

**NOTE: WARRANTY DOES NOT COVER THE PUSHER BLOCKS AND BLADE ASSEMBLY BLOCKS (PLUS PARTS).**

***WINCO warrants to the original purchaser of new equipment and non-electrical food preparation products (other than blades), when installed in accordance with our instructions within North America and subjected to normal use, is free from defects in material or workmanship for a period of 1 year. The labor warranty is one year from original installation or 18 months from actual factory shipment date, whichever date occurs first.***

**THIS WARRANTY IS IN LIEU OF ALL OTHER WARRANTIES, WHETHER EXPRESSED OR IMPLIED. WINCO EXPRESSLY DISCLAIMS ANY IMPLIED WARRANTY OF MERCHANTABILITY OR EXPRESSED OR IMPLIED WARRANTY OF FITNESS FOR A PARTICULAR PURPOSE.**

**WINCO'S OBLIGATION AND LIABILITY UNDER THIS WARRANTY IS EXPRESSLY LIMITED TO REPAIRING AND REPLACING EQUIPMENT THAT PROVES TO BE DEFECTIVE IN MATERIAL OR WORKMANSHIP WITHIN THE APPLICABLE WARRANTY PERIOD.**

**IN NO EVENT SHALL WINCO BE LIABLE FOR INCIDENTAL OR CONSEQUENTIAL DAMAGES TO BUYER OR ANY THIRD PARTY, INCLUDING, WITHOUT LIMITATION, LOSS OF PROPERTY, PERSONAL INJURY, LOSS OF BUSINESS OR PROFITS OR OTHER ECONOMIC LOSSES, OR STATUTORY OR EXEMPLARY DAMAGES, WHETHER IN NEGLIGENCE, WARRANTY, STRICT LIABILITY, OR OTHERWISE.**

***This warranty is given only to the first purchaser from a retail dealer. No warranty is given to subsequent transferees. Warranty does not cover product failures caused by: failure to maintain, neglect, abuse, damage due to excess water, fire, normal wear, improper set up and use. Periodic maintenance is not covered.***

***This warranty is not in force until such time as a properly completed and digitally signed Installation/Warranty Registration has been received by WINCO within 30 days from the date of installation.***

## **WARRANTY SERVICE**

***To initiate warranty service contact: [equipservice@wincous.com](mailto:equipservice@wincous.com) or call: 973-295-3899  
DO NOT send unit to WINCO® without first contacting our customer service department.***

## **REGISTER ONLINE AT:**

***<http://www.wincous.com>***

***Proof of purchase is required to extend warranty more than 1 year from date of shipment from the factory.***

**THE FOREGOING WARRANTY PROVISIONS ARE A COMPLETE AND EXCLUSIVE STATEMENT BETWEEN THE BUYER AND SELLER. WINCO® NEITHER ASSUMES NOR AUTHORIZES ANY PERSONS TO ASSUME FOR IT ANY OTHER OBLIGATION OR LIABILITY IN CONNECTION WITH SAID EQUIPMENT.**

## ***Examples of items not covered under warranty, but not limited to just these items:***

1. Acts of God, fire, water damage, burglary, accident, theft.
2. Freight damage.
3. Improper installation or alteration of equipment.
4. Use of generic or after-market parts.
5. Repairs made by anyone other than a WINCO® designated service provider.
6. Lubrication.
7. Expendable wear parts, adjustable feet, blown fuses, lamps, etc.
8. Cleaning of equipment.
9. Misuse or abuse.

**KATTEX** **winco**<sup>®</sup>  
www.winco.us.com  
**FRUIT WEDGER SLICER**

