

Visite www.wincous.com para ver manuales en francés y español.
Visitez www.wincous.com pour les manuels en français et en espagnol.

KATTEX by **winco**[®]
www.wincous.com

QUICK-SLICE TOMATO SLICER

TTS-188
TTS-188-S
TTS-250
TTS-250-S



Warranty Service
To initiate warranty service contact:
equipservice@wincous.com or call: 973-295-3899

DO NOT send unit to WINCO without first contacting
our customer service department.

For California Customers

 **WARNING:** Cancer and Reproductive Harm - www.P65Warnings.ca.gov

20191118

INTRODUCTION

Congratulations on the purchase of your KATTEX machine. Please take the time to carefully read through this manual to ensure the machine is operated and maintained properly, to ensure the best possible performance from this product for many years.

WINCO will not accept liability if:

- The instructions in this manual have not been followed correctly.
- Non-authorized personnel have tampered with the machine.
- Non-original spare parts are used.
- The machine has not been handled and cleaned correctly.
- There is any use damage to the unit.

SAFETY



WARNING: THE BLADES ARE VERY SHARP. PLEASE USE CAUTION WHEN HANDLING AND OPERATING THE MACHINE AND KEEP HANDS AWAY FROM ALL CUTTING EDGES.



AVERTISSEMENT: TRÈS COUPANTES TRÈS COUPANTES. VEUILLEZ FAIRE PREUVE DE PRUDENCE LORSQUE VOUS MANIPULEZ ET UTILISEZ LA MACHINE ET GARDEZ LES MAINS ÉLOIGNÉES DE TOUS LES BORDS DE COUPE.



WARNING: IMPROPER INSTALLATION, ADJUSTMENT, ALTERATION, SERVICE OR MAINTENANCE CAN CAUSE PROPERTY DAMAGE, INJURY, OR DEATH. READ THE INSTALLATION, OPERATION, AND MAINTENANCE INSTRUCTIONS THOROUGHLY BEFORE INSTALLING OR SERVICING THIS EQUIPMENT.



AVERTISSEMENT: TOUTE INSTALLATION, RÉGLAGE, MODIFICATION, RÉPARATION OU ENTRETIEN INCORRECT PEUT OCCASIONNER DES DOMMAGES MATÉRIELS, DES BLESSURES GRAVES OU LA MORT. LIRE LES INTRUCTIONS D'INSTALLATION, D'UTILISATION ET D'ENTRETIEN ATTENTIVEMENT AVANT D'INSTALLER OU DE RÉPARER CET APPAREIL.



CAUTION: THESE MODELS ARE DESIGNED, BUILT, AND SOLD FOR COMMERCIAL USE ONLY. IF THESE MODELS ARE POSITIONED SO THE GENERAL PUBLIC CAN USE THE EQUIPMENT, MAKE SURE THAT CAUTION SIGNS, WARNINGS, AND OPERATING INSTRUCTIONS ARE CLEARLY POSTED NEAR EACH UNIT SO THAT ANYONE USING THE EQUIPMENT WILL USE IT CORRECTLY AND NOT INJURE THEMSELVES OR HARM THE EQUIPMENT.



ATTENTION: CES MODÈLES SONT CONÇUS, FABRIQUÉS, ET VENDUS POUR UN USAGE COMMERCIAL SEULEMENT. SI CES MODÈLES SONT PLACÉS POUR QUE LE GRAND PUBLIC PUISSE LES UTILISER, ASSUREZ-VOUS QUE LES CONSIGNES D'ATTENTION, D'AVERTISSEMENT, ET LES INSTRUCTIONS D'UTILISATION SOIENT CLAIREMENT AFFICHÉES PRÈS DE CHAQUE UNITÉ DE SORTE QUE N'IMPORTE QUEL UTILISATEUR DE L'APPAREIL L'EMPLOIE CORRECTEMENT ET NE SE BLESSE PAS OU N'ENDOMMAGE PAS L'APPAREIL.



WARNING: A FACTORY AUTHORIZED SERVICE PROVIDER SHOULD HANDLE ALL MAINTENANCE AND REPAIR. BEFORE DOING ANY MAINTENANCE OR REPAIR, FOLLOW SERVICE SET UP ARRANGEMENT.



AVERTISSEMENT: UN TECHNICIEN AUTORISÉ PAR L'USINE DEVRA EFFECTUER TOUT L'ENTRETIEN ET LES RÉPARATIONS. AVANT DE FAIRE TOUT ENTRETIEN OU RÉPARATION, VEUILLEZ CONTACTER WINCO.

SAFETY (CONT.)

To ensure safe installation and operation, please carefully read and understand the following statements.

Unless the operator is adequately trained and supervised there is a possibility of serious injury. Owners of this equipment bear the responsibility to make certain that this equipment is used properly and safely, and to strictly follow all of the instructions contained in this manual and the requirements of local, state or federal law.

Owners should not permit anyone to touch this equipment unless they are over 18 years old, are adequately trained and supervised, and have read and understood this manual.

Owners should also ensure that no customers, visitors or other unauthorized personnel come in contact with this equipment. It is the responsibility of the owner and the operator to remain alert to any hazards posed by the function of this equipment.

If there is ever uncertainty about a particular task or the proper method of operating this equipment, ask an experienced supervisor.

Note: Please remember that this manual and the warning labels do not replace the need to be alert, to properly train and supervise operators, and to use common sense when using this equipment.

PACKAGE CONTENTS

All KATTEX Quick Slice Tomato Slicer come with the following:

- Assembled Quick Slice Tomator Slicer ([TTS-188/TTS-188-S/TTS-250/TTS-250-S](#))
- Table Stop
- Operating Instruction Manual

WINCO® prides itself on quality and service, ensuring that at the time of packing, all products are supplied fully functional and free of damage. Should you find any damage as result of freight, please contact your WINCO® dealer immediately.

UNPACKING THE EQUIPMENT

Dispose of all packaging materials in an environmentally responsible manner.

1. Remove all packing materials and tape, as well as any protective plastic and cardboard from the unit.
2. Clean any glue residue left over from the plastic or tape.
3. Place the unit in the desired position and height.

SAVE THE ORIGINAL BOX AND PACKAGING FOR USE IN PACKAGING AND SHIPPING THE EQUIPMENT IF SERVICES ARE NEEDED.

PREPARATION

INSTALL TABLE STOP (OPTIONAL)

1. Remove the screw from base of the Tomato Slicer.
2. Attach the table stop to the base of the Tomator Slicer by reconnecting the screw.
3. Secure the table stop to table with another screw (not included).

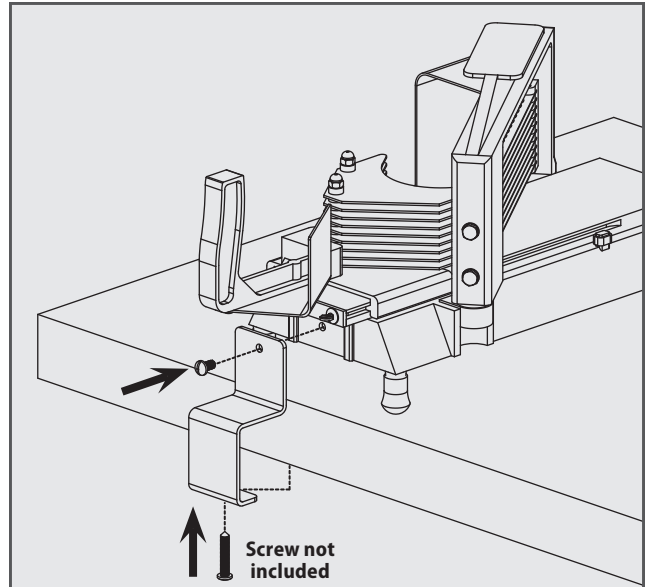

OPERATION

Note: Check the tension of the blades prior to each use to ensure they are tight.

1. Pull the handle towards you and carefully place the tomato or other produce onto the slide board between the pusher plates and the blades.



**WARNING: THE BLADES ARE VERY SHARP.
PLEASE USE CAUTION WHEN HANDLING**

2. Withdraw your hand. With one quick and seamless motion, push the handle towards the blades and catch the tomato in your hand or a container.
3. Remove the sliced tomato from the slide board and repeat the procedure as desired.

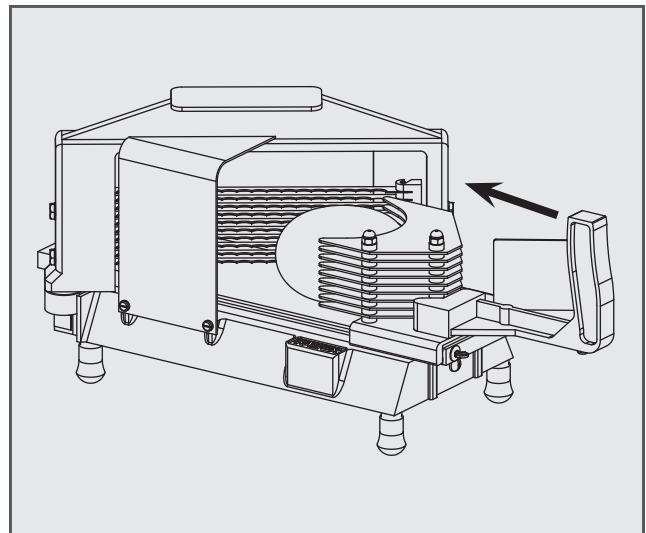

If the unit fails to properly operate during its first use, call Winco customer service at 973-295-3899 or email at equipservice@wincous.com.

DO NOT send unit to WINCO without first contacting our customer service department.

CLEANING

Should you wash the Tomato Slicer in hot water, make sure to always rinse in warm or cold water thereafter. Hot water may cause the slide board to expand, creating difficulty in pushing the pusher assembly until the slide board returns to room temperature.

Minimize the use of alkaline cleansers as they may cause pitting and dulling of the cast aluminum body finish.

1. To remove the pusher assembly for cleaning, remove the thumb screws and the slide stop. Then pull the pusher assembly off the end of the slide board.

Note: To fully disassemble for parts replacement or service, remove the acorn hex nuts and carefully remove the pusher plates and spacers.

Remove the other screws to disassemble the handle part from the guide plate.

2. The blade shield and blade assembly can be removed by removing the hex bolts and washers using the dual-sided wrench provided.

Tip: Loosen all hex nuts from hand blade shield before attempting to fully remove.

3. The slide board can be removed by removing the mounting screws underneath the tomato slicer.
4. Clean parts and reassemble.

Note: Hand washing unit is recommended as washing in a commercial dishwasher will cause the all aluminum parts to darken over time, this is normal, and does not effect the general operation of the unit.

Note: Blade assembly must be re-tensioned following reassembly.

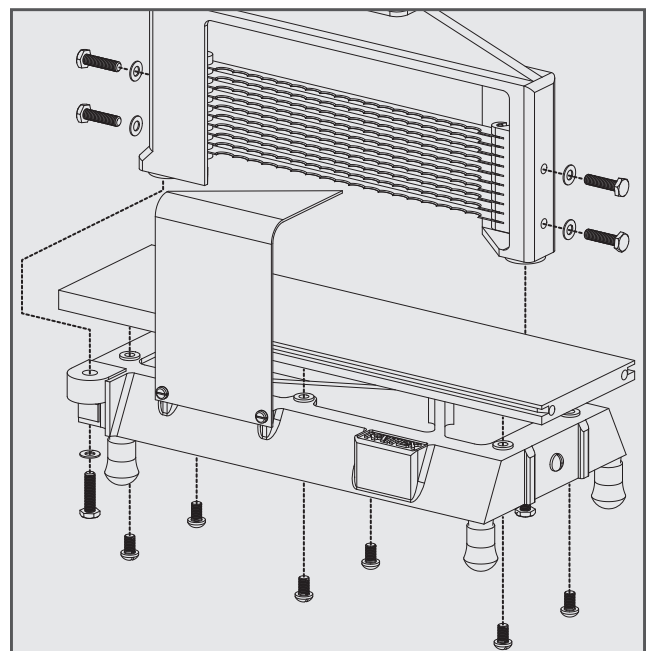
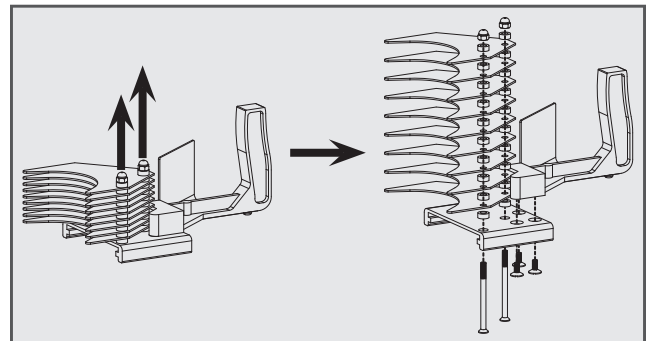
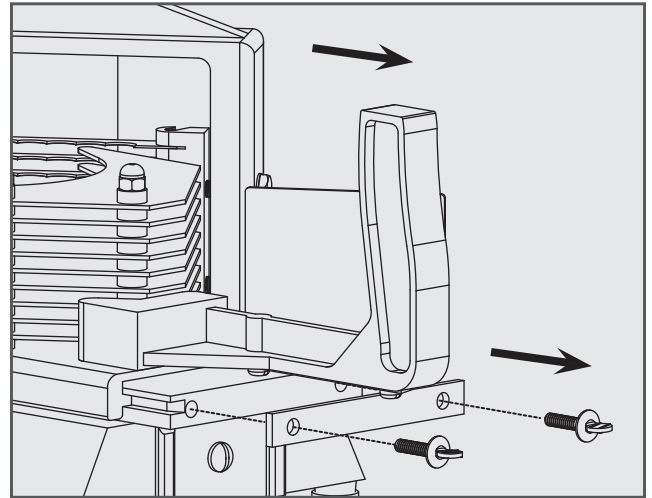

BLADE TENSIONING

Tension on the blades must be restored following each disassembly for cleaning or replacement of the blade assembly.



**WARNING: THE BLADES ARE VERY SHARP.
PLEASE USE CAUTION WHEN HANDLING**

Note: The blade assembly can be installed only one way with the longer offset facing up.

1. Be sure blade holder is firmly mounted on the Tomato Slicer base and the sharp side of the blades is facing toward the pusher assembly.
2. Attach hex screws and washers and tighten evenly using the dual-sided wrench.
3. To check the blade tightness, wear a thick protective glove and pluck or strum the back (unsharpened) side of the blades until the blades "hum". Gradually tighten the top and bottom hex screws until the top and bottom blades sound about the same when plucked or strummed.

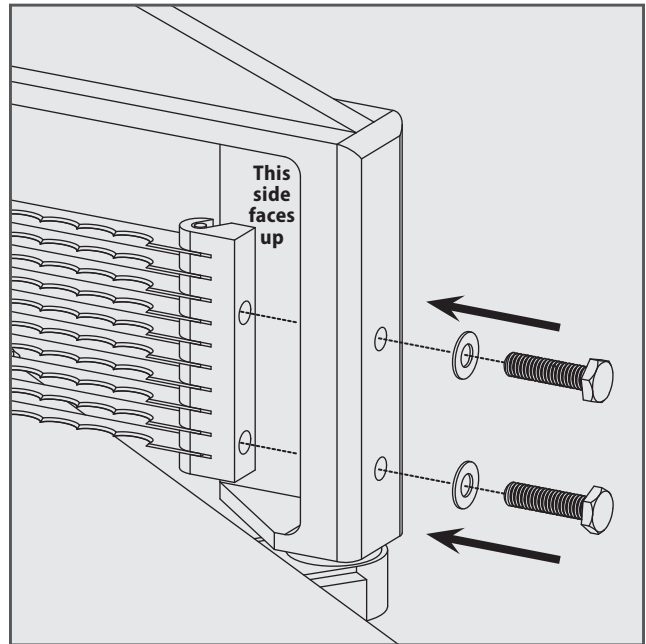

PARTS LIST

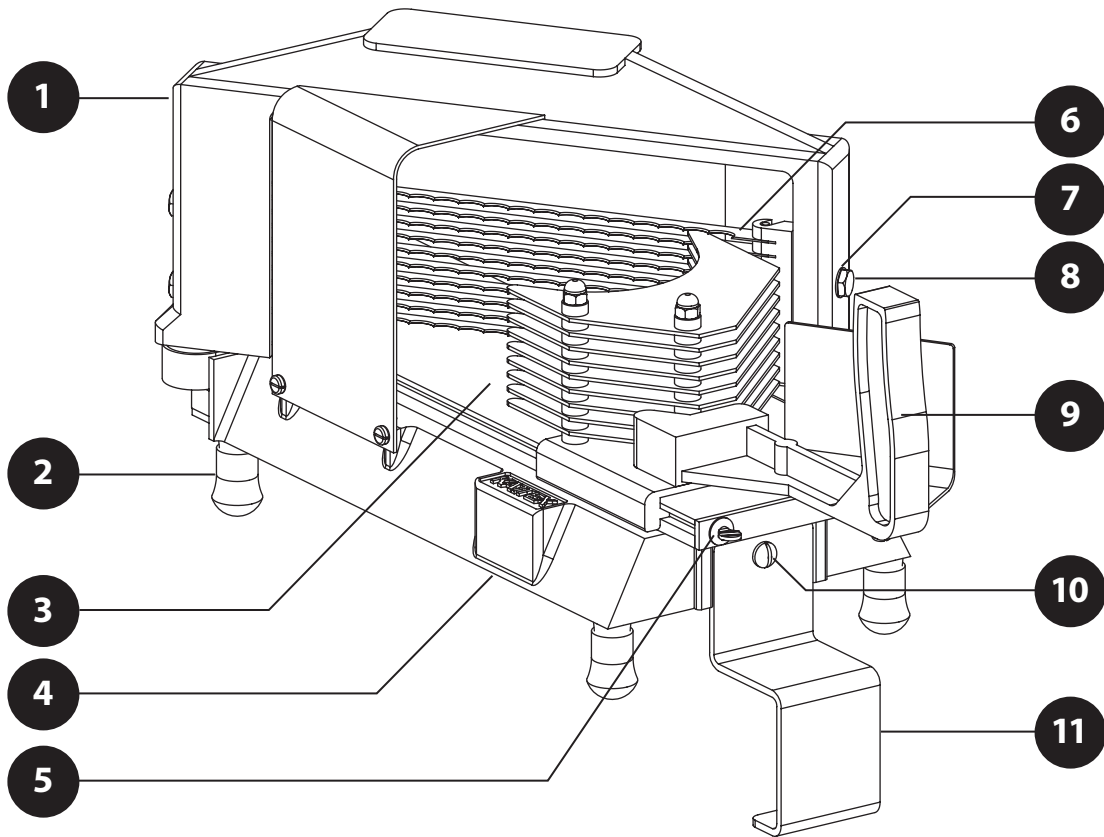

No.	Description	Part #	QTY
1	Blade Holder		1
2	Rubber Feet	KAT-FT	4
3	Slide Board		1
4	Base		1
5	Thumb Screws (2) & Slide Stop Set	TTS-SS	1
6	Blade Assembly		1
7	Blade Assembly Washer		4
8	Blade Assembly Hex Bolt		4
9	Pusher Assembly & Handle		1
10	Table Stop Screw		1
11	Table Stop		1
12	3/16" Straight Blade Assembly	TTS-188-B	1
13	3/16" Serrated Blade Assembly	TTS-188S-B	1
14	1/4" Straight Blade Assembly	TTS-250-B	1
15	1/4" Serrated Blade Assembly	TTS-250S-B	1
16	Dual-Sided Wrench	KAT-WR	1

Contact factory for parts not listed

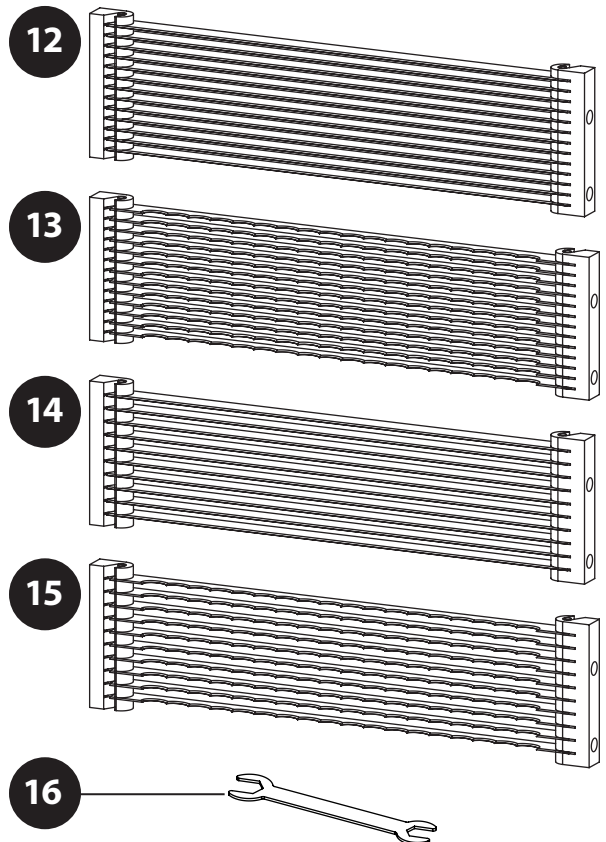

WARRANTY

NOTE: WARRANTY DOES NOT COVER THE PUSHER BLOCKS AND BLADE ASSEMBLY BLOCKS (PLUS PARTS).

WINCO warrants to the original purchaser of new equipment and non-electrical food preparation products (other than blades), when installed in accordance with our instructions within North America and subjected to normal use, is free from defects in material or workmanship for a period of 1 year. The labor warranty is one year from original installation or 18 months from actual factory shipment date, whichever date occurs first.

THIS WARRANTY IS IN LIEU OF ALL OTHER WARRANTIES, WHETHER EXPRESSED OR IMPLIED. WINCO EXPRESSLY DISCLAIMS ANY IMPLIED WARRANTY OF MERCHANTABILITY OR EXPRESSED OR IMPLIED WARRANTY OF FITNESS FOR A PARTICULAR PURPOSE.

WINCO'S OBLIGATION AND LIABILITY UNDER THIS WARRANTY IS EXPRESSLY LIMITED TO REPAIRING AND REPLACING EQUIPMENT THAT PROVES TO BE DEFECTIVE IN MATERIAL OR WORKMANSHIP WITHIN THE APPLICABLE WARRANTY PERIOD.

IN NO EVENT SHALL WINCO BE LIABLE FOR INCIDENTAL OR CONSEQUENTIAL DAMAGES TO BUYER OR ANY THIRD PARTY, INCLUDING, WITHOUT LIMITATION, LOSS OF PROPERTY, PERSONAL INJURY, LOSS OF BUSINESS OR PROFITS OR OTHER ECONOMIC LOSSES, OR STATUTORY OR EXEMPLARY DAMAGES, WHETHER IN NEGLIGENCE, WARRANTY, STRICT LIABILITY, OR OTHERWISE.

This warranty is given only to the first purchaser from a retail dealer. No warranty is given to subsequent transferees. Warranty does not cover product failures caused by: failure to maintain, neglect, abuse, damage due to excess water, fire, normal wear, improper set up and use. Periodic maintenance is not covered.

This warranty is not in force until such time as a properly completed and digitally signed Installation/Warranty Registration has been received by WINCO within 30 days from the date of installation.

WARRANTY SERVICE

***To initiate warranty service contact: equipservice@wincous.com or call: 973-295-3899
DO NOT send unit to WINCO® without first contacting our customer service department.***

REGISTER ONLINE AT:

<http://www.wincous.com>

Proof of purchase is required to extend warranty more than 1 year from date of shipment from the factory.

THE FOREGOING WARRANTY PROVISIONS ARE A COMPLETE AND EXCLUSIVE STATEMENT BETWEEN THE BUYER AND SELLER. WINCO® NEITHER ASSUMES NOR AUTHORIZES ANY PERSONS TO ASSUME FOR IT ANY OTHER OBLIGATION OR LIABILITY IN CONNECTION WITH SAID EQUIPMENT.

Examples of items not covered under warranty, but not limited to just these items:

1. Acts of God, fire, water damage, burglary, accident, theft.
2. Freight damage.
3. Improper installation or alteration of equipment.
4. Use of generic or after-market parts.
5. Repairs made by anyone other than a WINCO® designated service provider.
6. Lubrication.
7. Expendable wear parts, adjustable feet, blown fuses, lamps, etc.
8. Cleaning of equipment.
9. Misuse or abuse.