

OWNER'S , SERVICE & INSTRUCTION MANUAL

ZESTO

GAS CONVEYOR OVEN MODELS

CG 3018
CG 3624
CG 4824
CG 6024
CG 4032DD

CG 4018
CG 3632
CG 4832
CG 6032
CG 6532DD

IMPORTANT INSTRUCTIONS FOR OVEN INSTALLATION, OPERATION AND MAINTENANCE

GAS: MINIMUM PRESSURE AT THE OVEN, NATURAL GAS SHOULD BE 6" W.C. PROPANE GAS SHOULD BE 11.5" W.C. OVENS ARE EQUIPPED WITH 3/4" NPT SUPPLY LINE. **RECOMMENDATION:** FLEXIBLE 3/4" GAS CONNECTOR WITH RESTRAINING DEVICE (SUPPLIED BY OTHERS).

ELECTRICAL:

CG 3018 & CG 4018
120v 15 AMP NEMA 5-15R WALL RECEPTICLE REQUIRED

CG 3624, CG 3632, CG 4824, CG 4832, CG 6024, CG 6032
120v 20 AMP NEMA 5-20R WALL RECEPTICLE REQUIRED



CG 4032DD & CG 6532DD
208v / 240v SINGLE PHASE 15 AMP. DIRECT LINE

ZESTO

FOOD EQUIPMENT MANUFACTURING INC.
MANUFACTURIER D'EQUIPEMENT EN ALIMENTATION INC.

6450 HUTCHISON, MONTREAL, QUEBEC, H2V 4C8 TEL(514)278-4621 FAX(514)278-4622

e-mail: info@zesto.ca

www.zesto.ca

NOTICE: WHEN THIS APPLIANCE IS INSTALLED WITH CASTERS, IT MUST BE INSTALLED WITH THE CASTERS SUPPLIED, A CONNECTOR COMPLYING WITH EITHER ANSI Z21.69 OR CAN/CGA-6.16. AND A QUICK-DISCONNECT DEVICE COMPLYING WITH EITHER ANSI Z21.41 OR CAN 1-6.9. IT MUST ALSO BE INSTALLED WITH A RESTRAINING MEANS TO GUARD AGAINST TRANSMISSION OF STRAIN TO THE CONNECTOR , AS SPECIFIED IN THE APPLIANCE MANUFACTURER'S INSTALLATION INSTRUCTIONS.

IN THE COMMONWEALTH OF MASSACHUSETTS THIS APPLIANCES MUST BE INSTALLED UNDER AN EXHAUST HOOD AND MUST BE INTERLOCKED WITH THE GAS SYSTEM AND COMPLY WITH STATE PLUMBING CODES AND INSTALLED BY A LICENSED PLUMBER OR GAS FITTER.

IMPORTANT FOR YOUR SAFETY

Installation and service must be performed by a qualified installer, service agency or the gas supplier.

WARNING

This appliance is only for professional use and shall be used only by qualified people. All parts that have been protected by the manufacturer or his agent must not be adjusted by the end user.

Improper installation, adjustment, service or maintenance can cause property damage, injury or death. Read the installation, operating and maintenance instructions thoroughly before installing this equipment.

WHAT TO DO IF YOU SMELL GAS

- Do not try to light any appliance.
- Do not touch any electrical switch; do not use any phone in your building.
- Immediately call your gas supplier from a neighbor's phone. Follow the gas supplier's instructions.
- If you cannot reach your gas supplier, call the fire department.

FOR YOUR SAFETY

Do not store or use gasoline or flammable vapors or liquids in the vicinity of this or any other appliance.

IN THE EVENT OF A POWER FAILURE DO NOT ATTEMPT TO OPERATE THIS DEVICE. SHUT OFF POWER.

TABLE OF CONTENTS

GENERAL	4
Purchaser's Responsibility	4
INSTALLATION.....	4 - 7
Ventilation	4
Receiving	5
Location	5
Installation Codes and Standards	5
Gas Piping	5
Stacking Ovens	5
Installing Basic Oven	6 - 7
OPERATION	8 - 9
Temperature Control	8
Speed Control	9
MAINTENANCE	10 - 12
Cleaning	10 - 11
Belt removal for cleaning	12
ADJUSTMENTS - AIR & THERMOCOUPLE	13 - 16
Adjustment of Air Distribution	13 - 16
Thermocouple	16
TECHNICAL SERVICE	17 - 26
Gas Burner system	17 - 21
Burner Trouble Chart	22 - 23
Gear Motor	24
Heat Circulating Blower Motor	25
Cooling Fan (Axial)	26
WIRING DIAGRAMS	27a - 27b
TROUBLESHOOTING	28
COOKING CHART	29
WARRANTY	30

SAVE THESE INSTRUCTIONS FOR FUTURE USE

GENERAL

Read these instructions and keep them for future reference. Before installing the oven, consult your local building authority and obtain a building permit if necessary. Do not modify or alter the construction of the oven or any of its components. Install the oven as described in these instructions. Use only **ZESTO** components. Failure to do so will void the Certification approvals and the warranty of this oven.

PURCHASER'S RESPONSIBILITY

1. To see that the electric services for the oven are installed on site in accordance with the manufacturer's specifications.
2. To unload, uncrate and install the oven in its proper location in accordance with the Installation Operation Manual.
3. To see that the electric services are connected properly by a qualified installer of your choice. All such connections must be in accordance with applicable Code requirements.
4. To arrange for **inspection** and **operation check-out** by an authorized service technician as described below.
5. **Do not** attempt to operate the oven until connection of utility service has been fully inspected by an authorized service technician or a Zesto service representative.
6. The warranty shall not apply if the ovens are started up and operated prior to the utilities and oven being inspected and checked out by an authorized service technician or a Zesto service representative.

INSTALLATION

WARNING:

- * **INSTALLATION AND REPAIR SHOULD BE DONE BY A QUALIFIED SERVICE PERSON. THE APPLIANCE SHOULD BE INSPECTED BEFORE USE AND AT LEAST ANNUALLY BY A QUALIFIED SERVICE TECHNICIAN. MORE FREQUENT CLEANING MAY BE REQUIRED DUE TO OVEN GREASE VAPORS, DUST, ETC. IT IS IMPERATIVE THAT CONTROL COMPARTMENTS, BURNERS AND CIRCULATING AIR PASSAGEWAYS OF THE OVEN BE KEPT CLEAN.**
- * **DO NOT MODIFY THIS APPLIANCE.**
- * **DO NOT BLOCK THE AIR REGISTERS ON THE OVEN AS THIS WILL CAUSE THE OVEN TO OVERHEAT.**

WARNING: DO NOT USE THIS APPLIANCE IF ITS CONTROL HAS BEEN UNDER WATER. IMMEDIATELY CALL A QUALIFIED SERVICE TECHNICIAN TO INSPECT THE APPLIANCE AND TO REPLACE ANY PART OF THE CONTROL SYSTEM WHICH HAS BEEN UNDER WATER.

WARNING: ADEQUATE MEANS MUST BE PROVIDED TO LIMIT THE MOVEMENT OF CASTERED APPLIANCES. A RESTRAINING DEVICE IS REQUIRED FOR ALL TYPES OF MOVEABLE APPLIANCES.

VENTILATION:

1. Ventilation hood should extend 6" (15cm) minimum past the oven on the front and back and 6" (15cm) minimum past each side of the conveyor belt and hung 6'6" (198cm) above the floor surface.
2. Exhaust - Approximately 2000 CFM required for double stacked ovens.
Approximately 1500 CFM required for single oven.
Make-up air should be 65% - 80% of the exhaust air rating.

RECEIVING:

Immediately after receiving the oven, check for possible shipping damages. If this oven is found to be damaged, save the packaging material and contact the carrier within 15 days of delivery. Prior to installation, verify that the electrical service and type of gas (natural or propane) agree with the specifications on the oven data plate, located on right front side service panel. Do not use the door or the handle to lift oven.

LOCATION:

Verify that the doors and access routes into kitchen area are checked for clearance. (When crate is turned on its side, the oven will pass through a 864mm [34"] door opening). The equipment area must be kept free and clear of combustibles. Maintain clearances from combustible or noncombustible construction of at least 76mm (3") from the side and 76mm (3") from the back of the oven. The installation location must allow adequate clearances for servicing and proper operation.

INSTALLATION CODES AND STANDARDS:

This oven complies with the National Standards of Canada and the United States and is certified by the Warnock Hersey Inchcape Services and ETL under the standards of (CGA) Canadian Gas Association, (AGA) American Gas Association and National Sanitation Foundation (NSF). In Canada the installation must conform with local codes or, in the absence of local codes, with the current CAN/CGA B149 Installation Code. The oven, when installed, must be electrically grounded in accordance with the local codes or, in the absence of local codes, with the current Canadian Electrical Code: CSA C22.1. In the United States, installations must conform with local codes or, in the absence of local codes, with the National Fuel Gas Code; ANSI Z223.1 (latest edition).

The oven, when installed, must be electrically grounded in accordance with local codes or, in the absence of local codes, with the National Electrical Code; ANSI/NFPA 70 (latest edition). A separate 20 amps/110v wall receptacle must be provided for each oven. For stacked ovens, each oven must be considered as a separate oven.

GAS PIPING:

CAUTION: The available gas pressure should be within the limits shown in the SPECIFICATIONS section. Excessive pressure will damage Combination Valve and Regulator. If the supply pressure exceeds the 14.0" w.c. maximum, a suitable intermediate main regulator must be installed ahead of the Main Manual Shut-Off Valve.

- The burner gas supply piping should branch off from the main line as close to the gas meter as possible. Do not connect to the bottom of an horizontal section. Use new black pipe and malleable fittings free of cutting and threading burrs or defects.
- Provide a sediment trap, a union and 3/8" pressure tap in piping close to the burner.
- Use pipe joint compound approved for use with Liquid Petroleum Gases.
- Piping must comply with local codes.
- To obtain the maximum firing rate of 300 MBH, the NATURAL and PROPANE gas supply piping must be sized to provide a minimum of 4.0" W.C. pressure to the inlet of the combination valve when the burner and all other gas utilization equipment are on. For a firing rate of 225 MBH or less, 3.5" w.c. inlet pressure is sufficient.
- When selecting the burner supply pipe size per Table 2, the permissible pressure drop must be based on the pressure available at the inlet to the supply pipe branch line when **all other** gas utilization equipment is on.
- If the burner piping must be rearranged because of space limitations, be sure to carry out the general arrangement. Install the Combination valve in any position except up-side down.
- When the burner is installed in jacketed equipment, it is recommended that the combination valve be left adjacent to the burner within the vestibule and the Main Manual Shut-Off Valve be installed outside.

NOTE: *If there is more than 1.0" w.c. differential in the inlet pressure to the burner compared to when all other gas utilization equipment is off, refer to **COMBINATION GAS VALVE** last paragraph.*

CAUTION: Because it is difficult to accurately control pressure during supply pipe leak test, it is recommended that the Combination Valve be disconnected. Exposing the combination valve to a pressure over ½ psig (14.0" w.c.) will damage the valve and void all warranties.

DANGER! Explosion hazard.
Do not use oxygen for pressure testing.
An explosion could occur during initial start-up.

INSTALLING BASIC OVEN:

- 1) Tilt oven on back side
- 2) Place oven on 4 wheel dolly
- 3) Direct oven to location
- 4) Remove oven from dolly and place on 2 pieces of 4" (100mm) x 4" (100mm) wood
- 5) Undo crate
- 6) Fasten front legs to oven
- 7) Tilt oven forward resting on front legs
- 8) Lift oven from rear
- 9) Once oven is lifted fasten back legs to oven
- 10) Oven is now ready to be placed in operating location



STACKING OVENS:

Follow same procedure as above to uncrate and then lift and place oven on top of bottom one. No fasteners are required, the weight of the oven will keep it in place.

MODELLE CG/CE 3018, 3018HD, 4018

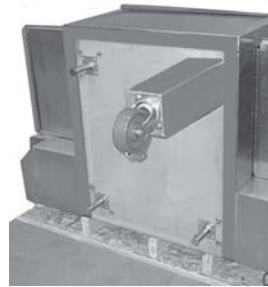
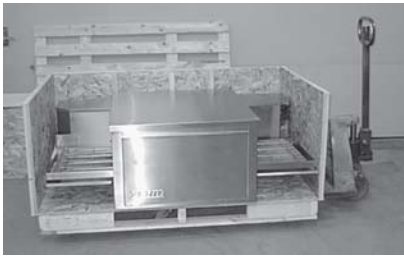

MODELLE CG/CE 3624, 3632, 4824, 4832, 6024, 6032



1)



2)



3)



4)



5)



6)



7)



8)



9)



10)



TEMPERATURE CONTROLLER:

REF #0908w-53

NOTE: * DON'T TOUCH THESE ADJUSTMENTS, IT'S ALREADY CALIBRATED

#VD 2001 / 2601 INITIAL POWER-UP: (Part #ZDIVD2001TRIDNA) When power is applied to the control it will begin operating using the factory set point. The process temperature as measured by the thermocouple will appear in the digital display and the **LOAD (PV)** will indicate if the control output (load) is on.











































Key-pad:

-  - Parameter display / set-point programming.
-  - Press to Raise Temperature of Oven.
-  - Press to Lower Temperature of Oven.



WARNING:

To program Controller follow the following steps:(adjustments to be done only by qualified technician)

- 1) Press and hold  for 5 seconds till *Pb* appears, then keep pressing toggling  till *LoLl* appears. Press  till you find 0 100 this unlocks the program.
- 2) Press  till *Pb* appears press  or  till you find 0.0.
- 3) Press  till *HYSL* appears press  or  till you find 2.
- 4) Press  till *RiHY* appears press  or  till you find 0.
- 5) Press and hold  for 5 seconds till *Pb* appears, then keep pressing toggling  till *LYPE* appears press  or  till you find *L* (K thermocouple)
- 6) Press  till *Unit* appears press  or  till you find F° or C°
- 7) Press  till *dP* appears press  or  till you find 0000.
- 8) Press  till *RcL* appears press  or  till you find *rEL*
- 9) Press  till *LoLl* appears press  or  till you find 0.
- 10) Press  till *H,LL* appears press  or  till you find $625F^{\circ}$ or $330C^{\circ}$.
- 11) Press  till *F,LL* appears press  or  till you find 5.0.
- 12) Press  and  holding both to exit program.
- 13) Press and hold  for 5 seconds till *Pb* appears, then keep pressing toggling  till *LoLl* appears. Press  or  till you find 0 001 this locks the program.
- 14) Press  and  holding both to exit program.

WIRING CONNECTION

- #11 Input Power
- #12 Output to selenoid or SSR
- #13 110v black
- #14 110v white

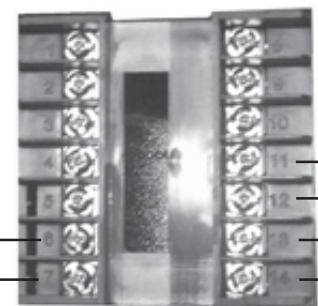

- #6 Thermocouple negative
- #7 Thermocouple positive

SPEED CONTROL: Model [ZRA620](#)

Speed control is made of three different parts: a digital time panel, a reverse switch for belt direction (for use by serviceman only) and an electronic pcb board.

This control is conected to a tachometer on the back of the gear drive motor which controls the amount of pulses to regulate the the speed. This is a closed loop system.

TO REGULATE SPEED OF BELT (1 - 20 minutes)



Press for slower rotation of belt (time)



Press for faster rotation of belt (time)

REVERSAL OF ROTATION:

You can reverse the rotation of the belt simply by removing the back panel on the control side of oven, locate the tippette switch and push the switch to the desired rotation (to be done by serviceman only).

NOTE: IF DIRECTION IS CHANGED BE SURE THAT BELT LINKS ARE CHANGED, LINKS SHOULD ALWAYS BE IN PULLING DIRECTION (see page 12)

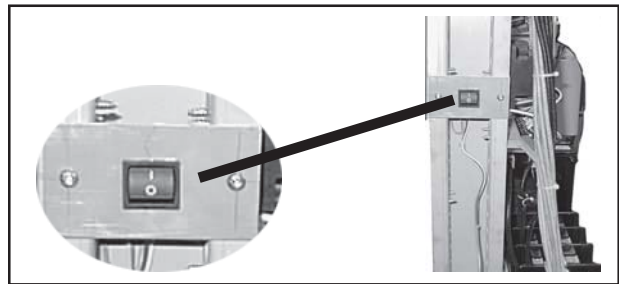

CAUTION:

In case of breakage of the electronic board do not touch any component; do not attempt to repair it. Service and calibration of the electronic board require special instruments and must be performed by the factory only. Failure to do so would void the warranty and the replacement of the defective electronic board.

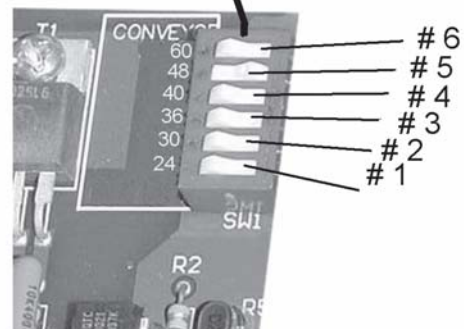
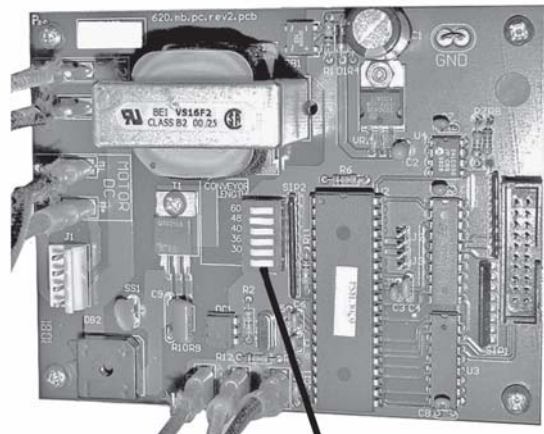

Settings to program different models

Models	Length of belt	Dip switch setting
CE 2416, 2418	48"	#1 (24" chamber)
CG & CE 3018	56"	#2 (30" chamber)
CG & CE 4018	66"	#4 (40" chamber)
CG & CE 3624, 3632	72"	#3 (36" chamber)
CG & CE 4824, 4832	84"	#5 (48" chamber)
CG & CE 6024, 6032	96"	#6 (60" chamber)
CG 4032 DD	72"	#4 (40" chamber)
CG 6532 DD	96"	#6 (60" chamber)

Periodically, depending on the amount of use and product you are cooking, the oven belt and cavity of the oven must be cleaned.

STEP # 1 Remove both exterior crumb trays daily and wash with soap & water.



STEP # 2 Remove chain cover panel.



STEP # 3 Lift belt and move forward thus loosening chain from belt shaft sprocket.

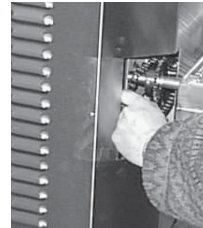

STEP # 4 Now you can remove the belt by carefully pulling back towards you.



STEP # 5 Remove bottom crumb tray first, then bottom air distribution panel and then the top air distribution panel. Cavity is now empty.



To clean interior of oven cavity wash with soap and water. If residue is hard or difficult to clean use a degreaser or abrasive cloth.

STEP # 6

It is imperative that the wire netting be kept clean and free of obstructions as this could cause the fan to stop which would result in serious damages to the air circulating motor inside the oven and would void the warranty of this product.

CLEAN WEEKLY THIS SHOULD BE DONE BY PASSING A DAMP CLOTH OVER WIRE NETTING.

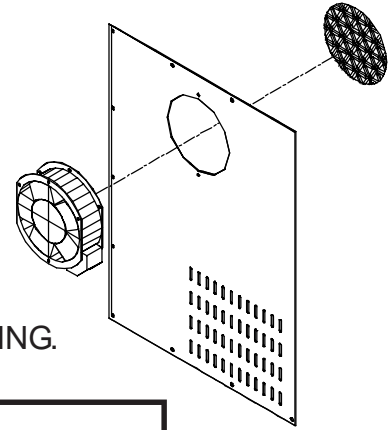

ATTENTION

Never use pressure water hose (Jet Spay) to clean oven to prevent any electrical hazards

REMOVING AND CLEANING WIRE BELT & FRAME:

STEP # 1

Rotate belt until you find chain link fasteners.

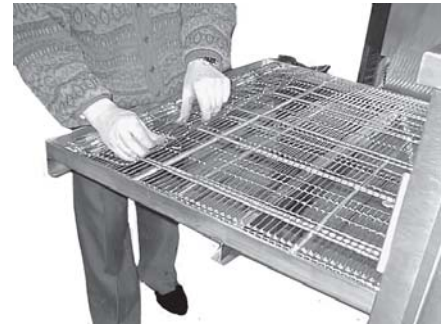
**STEP # 2**

Undo chain link fasteners.

**STEP # 3**

Roll belt and clean. Now you may clean stainless steel frame with soap and water, if residue is hard you may use a degreaser or abrasive cloth.

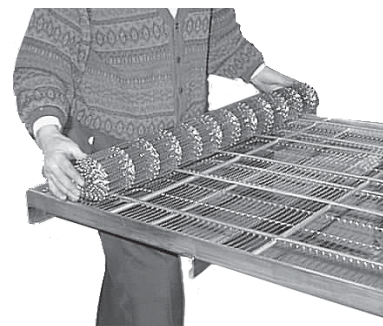

CONVEYOR BELT ASSEMBLING AND DISASSEMBLING INSTRUCTIONS:

Install belt so it always runs in the direction indicated by this arrow.
Closed end of loop towards direction of travel.

The arrows in the belt illustrate the movement of the splicing strand between steps.

When bending the splicing strand, try to limit bending to straight portions of the strand rather than in the "Z" bend area.

Splice one side completely before starting the other side.

After completely splicing the belt, it is advisable to go along the width of the belt straightening the spliced-in strand.

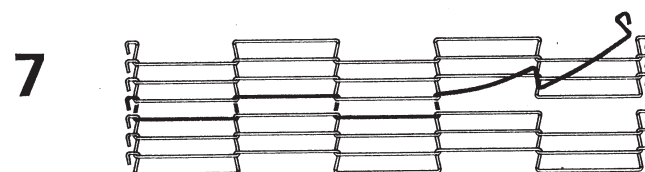
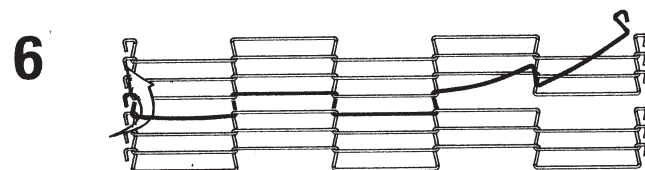
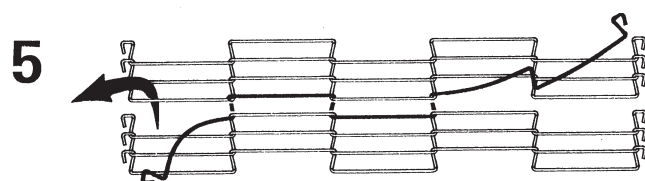
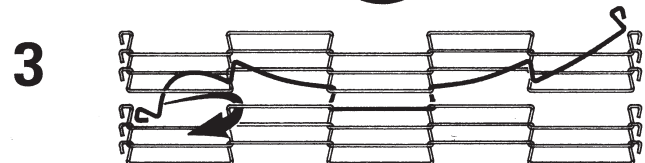
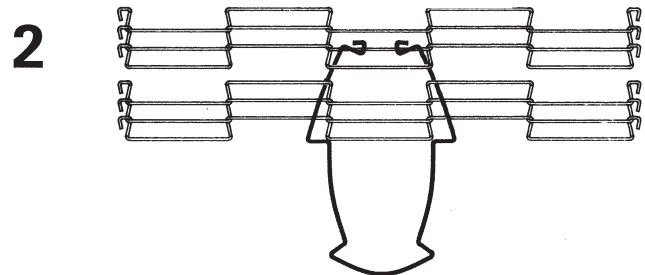
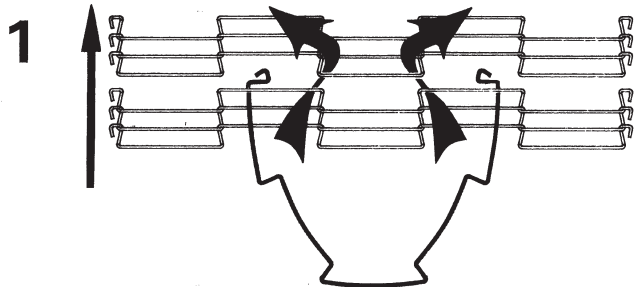

NOTE: DEPENDING ON WIDTH OF BELT THERE MIGHT BE ONE, TWO OR THREE SPLICING STRANDS.



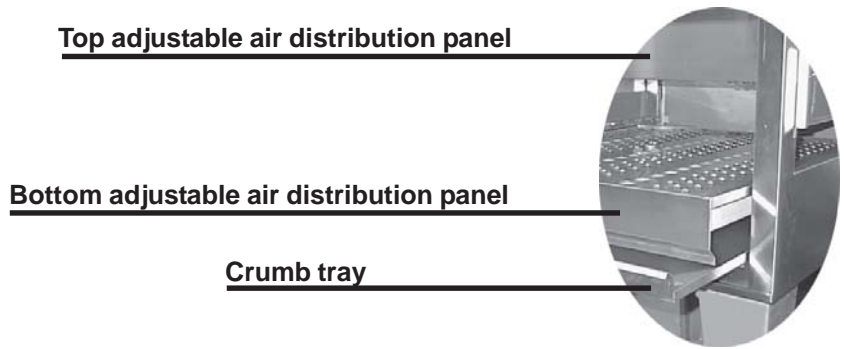

Ovens have a top adjustable air distribution panel, bottom adjustable air distribution panel and crumb tray.



TOP AIR DISTRIBUTION PANEL

 <p>Top</p>	MODEL	NUMBER OF CONDUITS	 <p>Top underside</p>
	3018	2	
	4018	2	
	3632 / 3624	2	
	4832 / 4824	3	
	6032 / 6024	4	
	4032 DD	4	
	6532 DD	6	

BOTTOM AIR DISTRIBUTION PANEL

 <p>Bottom</p>	MODEL	NUMBER OF CONDUITS	 <p>Bottom underside</p>
	3018	3	
	4018	4	
	3632 / 3624	4	
	4832 / 4824	5	
	6032 / 6024	6	
	4032 DD	4	
6532 DD	6		

TO ADJUST AIR FLOW:



- 1) Lift and pull out front panel with access door.
- 2) Pull out crumb tray.
- 3) Pull out bottom air distribution panel.
- 4) Pull out top air distribution panel.



AIR DISTRIBUTION PANEL ADJUSTMENT:

IMPORTANT NOTICE: All adjustments on conduits must be set to the same opening. Failing to set the same openings on all conduits will result in uneven cooking and air flow distribution.

Top Air Distribution panel has two adjustments, one for the quantity of air over product and the other to control the distribution of air front to back for even cooking.

To increase or decrease quantity of air (heat flow) on top of product:

- (1) Loosen bolts on top of conduits.
 Pushing top large lever towards the front of the conduit increases the quantity of air on top.
 Pushing top large lever towards the back of the conduit decreases the quantity of air on top.

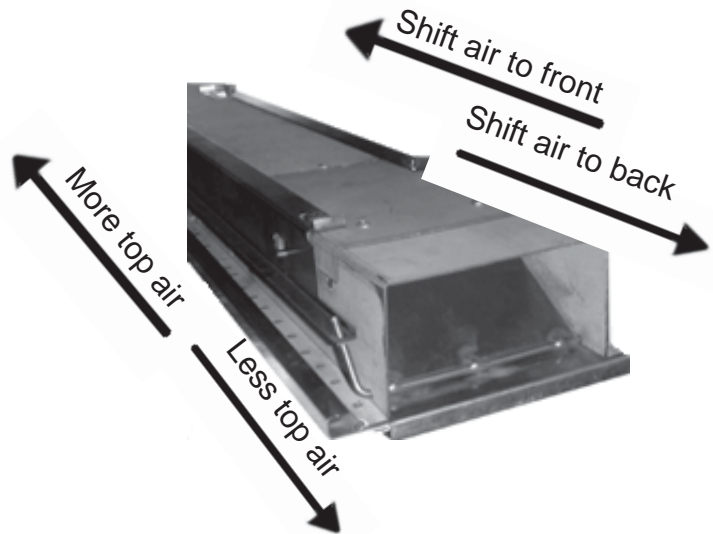

To shift air in top conduits:

- (2) Loosen bolts on top of conduits.
 Pushing top small lever towards the front of the conduit shifts the air to the front.
 Pushing top small lever towards the back of the conduit shifts the air to the back.

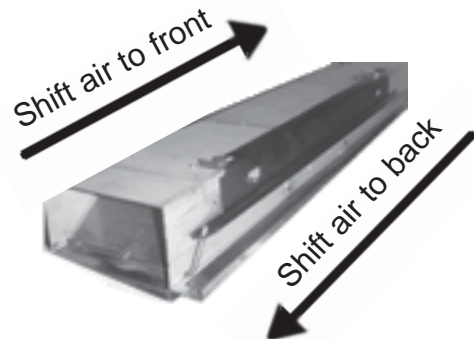

Bottom Air Distribution panel has one adjustment in each conduit to control the distribution of air from front to back for even cooking.

Loosen bolts on top of conduits.
 Pushing top small lever towards the front of the conduit shifts the air to the front.
 Pushing top small lever towards the back of the conduit shifts the air to the back.

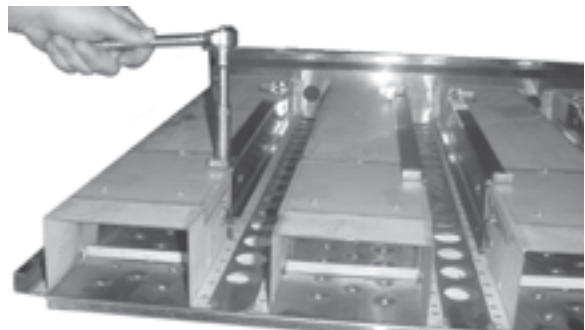

SEE DIAGRAM PAGE 15

Top air distribution panel

REF #0908w-53

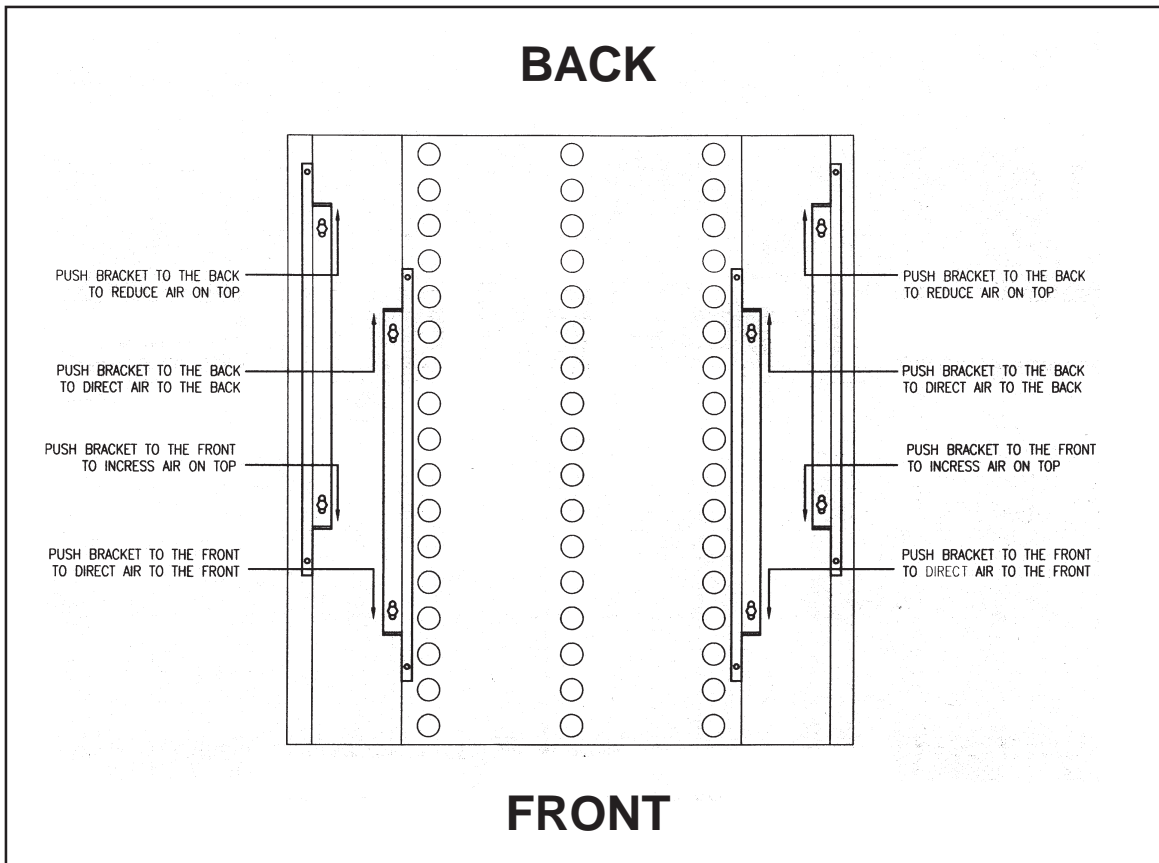

Bottom air distribution panel

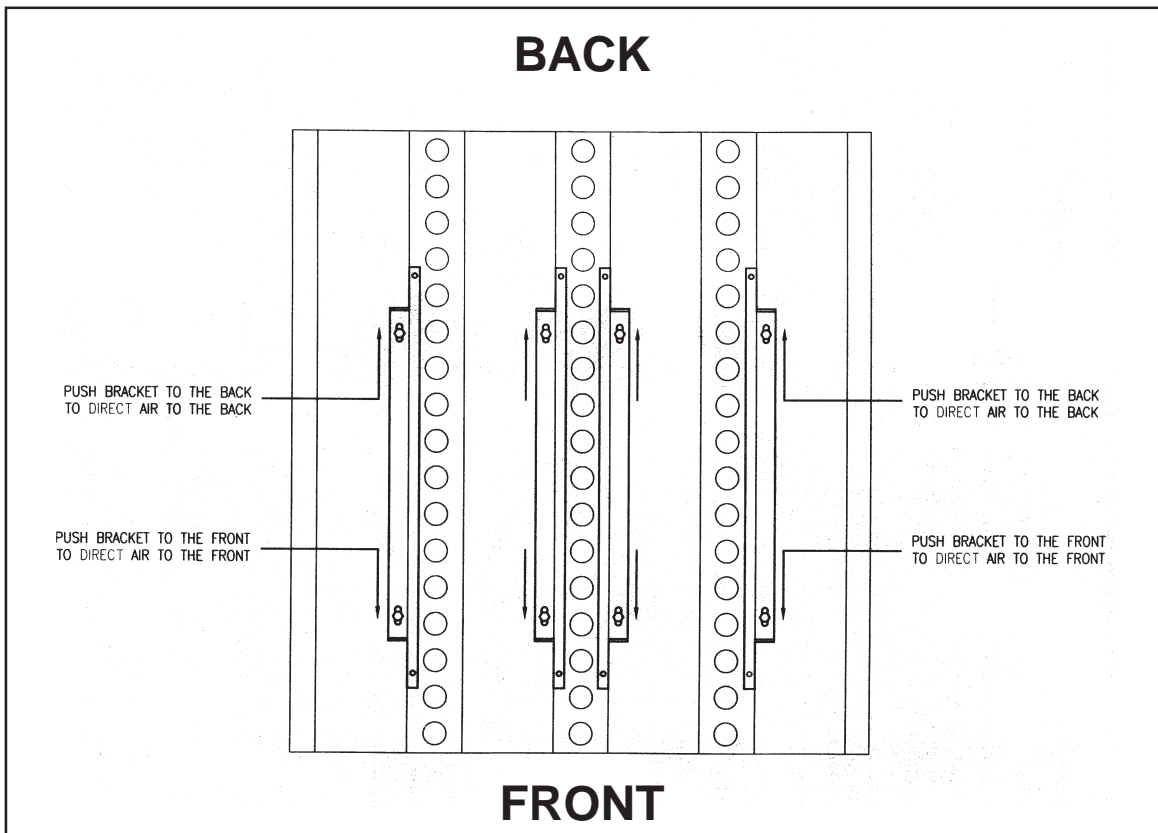

FACTORY SETTINGS FOR AIR DISTRIBUTION PANELS

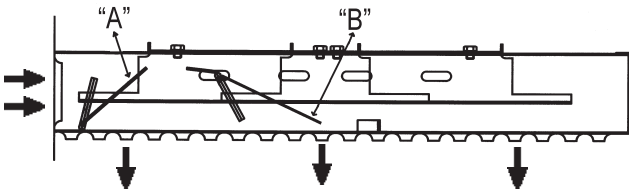
TOP DISTRIBUTION PANEL	<p>"A" Damper to adjust quantity of air distributed on top conduits.</p> <p>"B" Damper to adjust air flow from front to back and back to front.</p> 	MODELS	AIR FLOW SETTINGS	AIR SHIFT SETTINGS
		2416 / 2418	(A) 1 1/4"(32mm)	(B) 3/8" (9.5mm)
		3018	(A) 1 1/4"(32mm)	(B) 3/8" (9.5mm)
		4018	(A) 1 1/4"(32mm)	(B) 3/8" (9.5mm)
		3624 / 3632	(A) 1 1/4"(32mm)	(B) 3/8" (9.5mm)
		4824 / 4832	(A) 1 1/4"(32mm)	(B) 3/8" (9.5mm)
		6024 / 6032	(A) 1 1/4"(32mm)	(B) 3/8" (9.5mm)
		4032 DD / 6532 DD	(A) 1 1/4"(32mm)	(B) 3/8" (9.5mm)

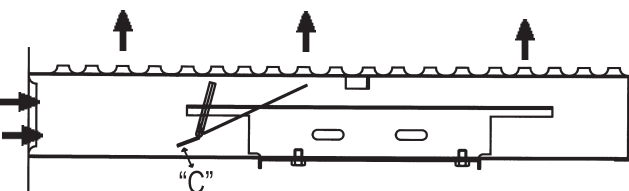
BOTTOM DISTRIBUTION PANEL	<p>"C" Damper to adjust air flow from front to back and back to front.</p> 	MODELS	AIR FLOW SETTINGS	AIR SHIFT SETTINGS
		2416 / 2418	NONE	(C) 3/8" (9.5mm)
		3018	NONE	(C) 3/8" (9.5mm)
		4018	NONE	(C) 3/8" (9.5mm)
		3624 / 3632	NONE	(C) 3/8" (9.5mm)
		4824 / 4832	NONE	(C) 3/8" (9.5mm)
		6024 / 6032	NONE	(C) 3/8" (9.5mm)
		4032 DD / 6532 DD	NONE	(C) 3/8" (9.5mm)

THERMOCOUPLE FOR TEMPERATURE CONTROLLER:

The thermocouple placement is very important as the bulb on the end is what directs the temperature controller to signal the burner to give more or less heat in the combustion chamber

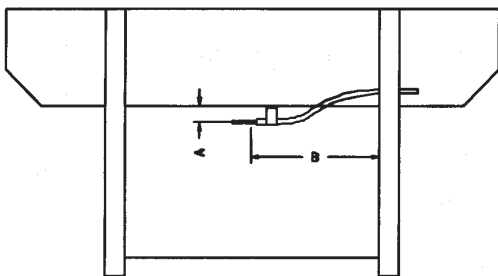

Top View

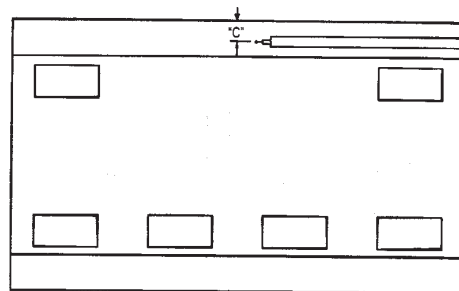

Front View

MODEL	DIMENSIONS "A"	DIMENSIONS "B"	DIMENSIONS "C"
2416 / 2418	2 1/4" (57mm)	9 5/8" (245mm)	1/2" (13mm)
3018	2 1/4" (57mm)	9 5/8" (245mm)	1/2" (13mm)
4018	2 1/4" (57mm)	10 3/4" (273mm)	1/2" (13mm)
3632 / 3624	1 3/4" (45mm)	16" (407mm)	1 3/16" (30mm)
4832 / 4824	1 3/4" (45mm)	17 3/16" (436mm)	1 3/16" (30mm)
6032 / 6024	1 3/4" (45mm)	19 1/16" (484mm)	1 3/16" (30mm)
4032 DD / 6532 DD	1 3/4" (45mm)	17 3/16" (436mm)	1 3/16" (30mm)

TECHNICAL SECTION FOR SERVICE

TABLE 2: Supply Pipe Capacities in MBH

SUPPLY PIPING CAPACITIES IN MBH						
PIPE SIZE	TYPE OF GAS	APPROX. CAPACITY - MBH				
		LENGTH OF PIPE				
		10 ft	20 ft	40 ft	60 ft	100 ft
3/4 "	NATURAL	275,000	190,000	130,000	105,000	80,000
	PROPANE	300,000	300,000	205,000	165,000	125,000
1 "	NATURAL	300,000	300,000	245,000	195,000	150,000
	PROPANE			300,000	300,000	235,000
1 1/4 "	NATURAL			300,000	300,000	300,000
	PROPANE					300,000

Capacities shown are for a total pressure drop of 3.0" w.c. For higher permissible pressure drops, consult your fuel supplier. Source, Gas Engineering Handbook - 1974.

SPECIFICATIONS

NATURAL GAS AND PROPANE

RATING BASED ON 1000 BTU / CU. FT. FOR NATURAL GAS AND 2500 BTU / CU. FT. FOR PROPANE GAS AT SEA LEVEL. DERATE BURNER FOR ALTITUDES OVER 2000 FEET BY 4% FOR EACH 1000 FEET ABOVE SEA LEVEL

		NATURAL GAS			PROPANE (L.P.)		
MODEL	BTU	INLET PRESSURE 5.0" to 14.0" w.c.			INLET PRESSURE 11.0" to 14.0" w.c.		
		NOZZLE DRILL SIZE	AIR SHUTTER POSITION	MANIFOLD	NOZZLE DRILL SIZE	AIR SHUTTER POSITION	MANIFOLD
CG 3018 / VRS	50,000	.1285" dia.	Number 1.5	3.0" w.c.	.082" dia.	Number 1.5	10.0" w.c.
CG 4018 / VRS	60,000	.147" dia.	Number 1.5	2.8" w.c.	.086" dia.	Number 1.5	10.0" w.c.
CG 3624 / VRS	100,000	.201" dia.	Number 2.5	3.0" w.c.	.107" dia.	Number 2.0	10.0" w.c.
CG 3632 / VRS	120,000	.2055" dia.	Number 2.5	3.0" w.c.	.120" dia.	Number 2.0	10.0" w.c.
CG 4824 / VRS	120,000	.2055" dia.	Number 2.5	3.0" w.c.	.120" dia.	Number 2.5	10.0" w.c.
CG 4832 / VRS	140,000	.228" dia.	Number 2.5	3.0" w.c.	.1285" dia.	Number 2.5	10.0" w.c.
CG 6024 / VRS	140,000	.228" dia.	Number 2.5	3.0" w.c.	.1285" dia.	Number 2.5	10.0" w.c.
CG 6032 / VRS	160,000	.250" dia.	Number 3.0	3.0" w.c.	.147" dia.	Number 3.0	10.0" w.c.
CG 4032DD	180,000	.2656" dia.	Number 4.0	3.0" w.c.	.154" dia.	Number 4.0	10.0" w.c.
CG 6532DD	225,000	.2812" dia.	Number 5.0	3.5" w.c.	.1719" dia.	Number 5.0	10.0" w.c.

BTU CAPACITIES FOR CONNECTORS

MOVABLE GAS CONNECTORS

Catalog Number	I.D.	Flow Rating BTU 0.64 SP.GR @ 0.5 in w.c. Pressure Drop					
		12"	24"	36"	48"	60"	72"
1675B, 1675BP	3/4"	326,000	291,000	256,000	225,000	198,000	175,000
1675BQ, BPQ & BPQ-B	3/4"	260,000	232,000	218,000	180,000	158,000	139,000
16100 B, 16100 BP	1"	652,000	582,000	512,000	451,000	397,000	350,000
16100 BQ, BPQ & BPQ-B	1"	425,000	414,000	379,000	334,000	294,000	279,000

MOVABLE GAS CONNECTORS WITH SUPR-SWIVEL FITTINGS							
Catalog Number	I.D.	12"	24"	36"	48"	60"	72"
1675 BPQ-S	3/4"	242,000	216,000	203,000	167,000	147,000	130,000
1675 BPQ-2S	3/4"	230,000	205,000	193,000	160,000	140,000	124,000

STATIONARY GAS CONNECTORS							
Catalog Number	I.D.	12"	24"	36"	48"	60"	72"
1675 N(FS)	3/4"	326,000	291,000	256,000	225,000	198,000	175,000
1675 N(PFS)	3/4"	326,000	291,000	256,000	225,000	198,000	175,000

NOTES: Capacities decrease when the length of the connector increases.

Capacities for gas connectors (B & BP models) are defined by ANSI Z21.69

A.G.A. and C.G.A. Laboratories design certify gas connectors at a pressure of 5 lbs. per square inch maximum.

Capacities shown, which exceed minimum ANSI requirements, are arrived at through an independent testing lab.

BURNER ELECTRONIC CONTROL SYSTEM:

The Electronic Control is a solid state device that automatically ignites and monitors the pilot flame. It has an integral high voltage transformer and upon a call for heat, applies high voltage to the spark electrode and 24 volts to the pilot valve. When the pilot flame is established and proven, the control powers the main automatic valve.

- If the pilot flame is not proven within 90 seconds, or if the proof of the flame is lost during the burner run and the pilot is not re-established within 90 seconds, the control will shut off the combination valve and **lock out**. To reset the control for restart, de-energize the control by setting the operating control to **OFF** or thermostat below room temperature for at least 60 seconds.
- If the Electronic Control is changed, the replacement must be identical to the make and model number, or must be an authorized substitute.

WARNING: EXPLOSION HAZARD. CAN CAUSE SERIOUS INJURY OR DEATH. THIS DEVICE CAN MALFUNCTION IF IT GETS WET. NEVER TRY TO USE A DEVICE THAT HAS BEEN WET - REPLACE IT.

BURNER DRAWER ASSEMBLY:

DANGER: Be sure the manual Main Shut-Off Valve combination valve and Burner Power Switch are turned OFF before removing any parts for service.

When the pilot flame gas pressure is in the proper range (see Table 4), lint, dust, or corrosion is the most common cause of pilot problems.

- The retention plate and pilot are part of the drawer assembly which can be removed as a unit. Remove the four back plate screws; then, disconnect the pipe union, pilot tube and control wires and pull out the drawer assembly.
- When servicing, clean the retention plate ports and pilot assembly including the pilot spud and electrode porcelain on sensor rod and/or spark electrode. Examine the sensor rod. If there is any serious corrosion or loss of metal at the tip replace the sensor rod.
- Make sure that the pilot mica peepsight is not damaged or missing as air leakage through the peepsight hole could mimic some of the conditions described below.
- Check that the pilot orifice size is correct.

Make sure that the burner tube is properly positioned in the combustion chamber entry. It must be set flush to 1/4" short of the inside of the combustion chamber. It must not protrude into the combustion chamber.

- If cleaning does not eliminate the lighting problem, further checks are required:

CAUTION: Do not indiscriminately increase pilot orifice size. Pilot troubles are rarely cured in this manner and new troubles may be introduced by causing the pilot flame to float and lose contact with the sensor rod.

- If the standby gas pressure is over 14.0" w.c., or less than 4.0" w.c., refer to Page 8 (Piping).
- If the standby gas pressure is between 4.0" w.c. and 14" w.c. and does not vary more than 1.0" w.c., use the pilot adjustment screw in the **combination valve section** to set the pilot flame gas pressure at 4.0" w.c.
- If the inlet pressure varies more than 1.0" w.c., a 1/8" Maxitrol RV12 (or equal) pressure regulator set for an outlet pressure of 3.5" w.c. must be installed in the pilot gas line and the pilot adjustment screw set full open.

TABLE 4 - Pilot Specifications

Nominal BTU Value		
	Natural Gas - 1000	Propane Gas - 2500
Orifice Diameter	.024	.018
Pilot Flame Gas Pressure	3.0" w.c. - 4.0" w.c.	10.0" w.c. - 14.0" w.c.
Approx. Capacity	2400 BTU / hre	

CONVERTING BURNER FROM LP to NATURAL GAS OR NATURAL to LP GAS:

- 1). Spring in valve must be changed. (LP spring conversion kit # ZWA62672-001)
- 2). Burner main manifold orifice must be changed (see chart page 17)
- 3) Pilot orifice must be changed (see above LP Pilot Orifice # [ZWA60680](#))

BURNER BLOWER ASSEMBLY:

Cleaning of the blower wheel is usually the only service required. Need for cleaning is indicated if the inlet screen or blower wheel shows an accumulation of dust and lint, or if the character of the flame indicates a deficiency of air. Motor cooling air vents should also be cleaned at this time.

- If the motor must be replaced: Disconnect motor leads, remove inlet ring and screen, blower wheel and the three motor mount retainer clips. Pull motor out of keyhole brackets. Remount in reverse order noting that brass flanges of rubber motor mounts are located against motor. The wheel should be located 1/4" inside the edge of the inlet side of the blower housing.

COMBINATION GAS VALVE:

The 24 volt combination valve serves four functions:

1. Manual gas shut-off.
2. Manifold gas pressure regulation.
3. Automatic electric pilot gas valve
4. Automatic electric redundant main gas valve.

A PILOT ADJUSTMENT SCREW AND FILTER ARE ALSO INCLUDED.

- The pilot adjustment screw is located on the combination valve. Remove plug for access and turn clockwise to reduce flow.
- The main gas pressure regulator, which has an outlet pressure setting range of 2.0" w.c. to 4.0" w.c. is factory set for a manifold gas pressure of 2.0" w.c. If pressure adjustment is required for setting capacity, remove regulator cap for access to slotted adjustment screw. Turning of adjustment screw counterclockwise reduces pressure; clockwise increases pressure. Do not adjust past point where no change in pressure is noted.

NOTE: *Pressure setting must be made with burner running and main gas ON.*

CAUTION: **If gas supply pressure is below its specified range during regulator adjustment, an over fire condition could result when pressure returns to normal, particularly if the regulator adjustment screw is bottomed out.**

ALWAYS confirm that at least the minimum rated gas pressure is being supplied to the burner during regulator adjustment, and **NEVER bottom out** regulator screw.

- The tap for manifold gas pressure measurement is located in the Burner Inlet Block. Remove plug for access.
- If the gas pressure regulator fails to maintain a constant manifold gas pressure within ± 0.1 " w.c., and it is confirmed that the inlet gas pressure to the combination valve is 14.0" W.C. maximum during standby, and 4.0" w.c. minimum with the main flame on, the regulator portion of the valve is defective and entire valve must be replaced.
- If, on a call for heat, the main flame ignition does not occur even though the pilot is burning, failure of the electric main valve operator may be indicated. Refer to the **trouble chart** for further information.

CAUTION: If the combination valve has been moved or replaced, soap bubble test for leaks with the burner running.

If leakage through the valve occurs, as evidenced by presence of pilot and/or main flame on standby, the entire valve must be replaced.

INITIAL START UP / ADJUSTMENT

WARNING: Ignition is automatic. Make spark observations into combustion chamber only with Main Manual Shut-Off Valve closed. Confirm that gas utilization equipment does not contain any accumulated gases. Purge as described in step 3 below.

1. Check the burner piping and valves for gas leaks by applying a weak liquid soap solution to unions and joints with the gas supply on. Leakage will be indicated by the appearance of soap bubbles. Locate and correct all gas leaks before proceeding.

WARNING: DO NOT USE OPEN FLAME

2. Purging the air from the gas line at this point will expedite the first start as described below.

CAUTION: Purge outside the building. Do not purge into the gas utilization equipment.

3. To purge the gas utilization equipment and oven of any accumulated gases, turn Manual Gas Cock Knob on the Combination Valve to **OFF**, turn burner power **ON** and set the operating control to **ON** or thermostat to call for heat. Let the blower run long enough to accomplish four air changes, but not less than five minutes.
4. **CAUTION: Make sure that the capacity range of the installed spud, and the preliminary gas pressure is suitable for the input rating of the gas utilization equipment.**
5. Reset the Electronic Control by setting the operating control to **OFF** or the thermostat below room temperature for at least 60 seconds.
6. Turn manual Gas Cock Knob on Combination Valve to **ON**.
7. Turn operating control to **ON** or set thermostat above room temperature. A few seconds after the motor reaches operating speed the pilot should light, followed by the main flame. If the burner fails to light within 90 seconds, the Electronic Control will shut off the pilot and main valves and will **lock out**. To reset the Electronic Control for restart, de-energize the control by setting the operating control to **OFF** or thermostat below room temperature for at least 60 seconds. If burner still fails to light, turn it off and repeat from step 4. Then, if necessary, refer to the **trouble chart** to isolate the problem.

WARNING: Repeated unsuccessful attempts to light will result in accumulated gases in combustion chamber. To prevent these gases from reaching an explosive level, periodically purge the gas utilization equipment and oven as described in step 3 above.

8. To make a preliminary setting of the burner input, determine the manifold gas pressure required from Table 3 and adjust the combination valve pressure regulator accordingly.
9. To determine the firing rate for NATURAL GAS:

Accurately time **test dial** for the number of seconds for one revolution and use the following formula. All other gas utilization equipment must be off.

$$\frac{3600 \times \text{test dial size} \times \text{BTU value}}{\text{No. of seconds for one rev. test dial}} = \text{BTU/Hr}$$

Then divide by 1 000 for MBH value. For PROPANE gas, consult your supplier for method of determining firing rate.

10. Readjust the primary air shutter to provide a quiet, soft blue flame with well defined orange and yellow tips for NATURAL gas or with well defined yellow tips for PROPANE gas.
11. Check the operation of the burner; start and stop it several times with the thermostat or operating control.
12. With the burner running, check the operation of all limit and associated controls.
13. **PERFORM THE FOLLOWING FINAL ADJUSTMENTS** for combustion and flue gas temperature. Take the flue gas samples and temperature immediately ahead of the draft control.
 - * The flue gas temperature should be above 325° F but not exceeding 550° F. Excessive flue gas temperatures will result in low efficiencies. Low flue gas temperature may cause excessive condensation. Reset gas input if necessary to adjust stack temperature.
 - * Make the final setting of the primary air shutter by checking the flue gases with an **ORSAT** or similar combustion testing instrument. The carbon monoxide content should conform to local codes or, in their absence, to the level specified in the United States or Canadian Standard reference on page 5 of this manual; the carbon dioxide content should be approximately 9.5% for NATURAL and 12.1% for PROPANE, or within the limits prescribed by the room.
14. Check the draft control to make sure there is no spillage of flue products into the room.

BURNER TROUBLE CHART:

Make sure the thermostat and operating controls are calling for heat. Defective wiring or loose connections can simulate the component defects outlined below. Check associated wiring before replacing a component.

ELECTRICAL AND FLAME CHECKS MUST BE MADE IN THE ORDER LISTED

I. MOTOR WILL NOT RUN OR MOTOR RUNS IN REPEATED CYCLES.

- A. Confirm 120V between strip terminals **1** and **2** and verify the circuit polarity and electrical ground, between strip terminal **1** and burner chassis metal.
- B. Check 24V * operating control circuit:
 1. Between left strip terminal **T** and **GND**.
 - * No voltage, transformer defective
 - * Very low voltage,* circuit overloaded or tranformer defective
 2. Between right strip terminal **T** and **GND**..
 - * No voltage: circuit between **T** and **T** is open
- C. Confirm 120V between strip terminal **2** and motor relay terminal **4**:
 1. No voltage, motor relay is defective.
 2. Voltage present, motor is defective.

II. MOTOR RUNS CONTINUOUSLY, BUT NO FLAME.

- A. Confirm that both Main Manual Shut-Off and combination gas shut-off valves are in the **ON** position.
- B. If the pilot flame is not proven within 90 seconds, or if the proof of flame is lost during the burner run and the pilot is not re-established within 90 seconds, the Electronic Control will **lock out**. To reset the control for restart, de-energize the Electronic Control by settinf the operating control to **OFF** or thermostat below room temperature for at least 60 seconds.
 1. No pilot flame.
 - * Check for 24V* between Electronic Control terminal **24V** and strip terminal **GND**. No voltage. Blower Motor Interlock Switch is defective.
- C. For each of the following tests, reset the Electronic Control per step II.B. **TESTS ARE VALID ONLY DURING THE 90 SECOND TRIAL FOR IGNITION.**
 1. **TURN MANUAL GAS COCK KNOB OFF.** Check for 24V* between Electronic Control terminal **PV** and strip terminal **GND**. No voltage, Electronic Control is defective.
 2. Check for 24V* between pilot valve terminal **PV** on the combination valve and terminal strip **GND**. No voltage, defective valve wire harness. Voltage present, pilot valve operator is defective, replace valve.
 3. Connect manometer to pilot flame gas pressure tap. **TURN MANUAL GAS COCK KNOB ON.** Separate main valve wire at harness splice. During trial for pilot ignition period, check gas pressure.
 - * No pressure, confirm that both Main Manual Shut-Off and combination gas shut-off valves and pilot adjustment screw are full open. Repeat step 3, and if stilll no pressure, pilot valve operator is defective.
 - * Pilot flame pressure is 3.0" to 4.0" W.C., continue with step4.
 - * Refer to **Standby Gas Pressure** requirements in Section IX and adjust or regulate the pilot gas pressure as indicated.

4. Check for ignition spark (spark gap is approx. $5/32 \pm 1/32$). Since this is a capacitor discharge system, observe closely when visually checking the spark as it is faint and thread-like and may be overlooked in bright light.

* Between Electronic Control high voltage terminal and strip terminal **GND**. No spark, defective Electronic Control.

* Check for ignition spark at electrode tip. No spark, defective electrode or cable.

* Check for gas flow at pilot tip. No flow, clogged pilot spud or pilot tube.

III. FLAME ON ONLY DURING TRIAL FOR IGNITION PERIOD.

A. With motor running and flame off, check line voltage terminals for voltage as follows:

1. Between strip terminals **1** and **2** - 120V; voltage OK.
2. Between strip terminals **1** and **GND** - 120V; ground OK.
3. Between strip terminals **2** and **GND** - «0» V; no backfeed OK.

B. Follow reset procedure as specified in step II.B.

1. Check sensor wire for continuity.

2. Separate main valve wire at harness splice. Connect DC microamp meter in series with sensor wire and Electronic Control. With pilot only burning, flame signal should not be less than 2 microamps. Adjust pilot flame gas pressure per Section IX to obtain acceptable signal and note gas pressure and resultant signal for future reference.

3. Reconnect separated main valve wire at harness. After main flame comes on, flame signal should increase. If signal does not increase, a rich flame is indicated. Refer to Table 3 for approximate air shutter and/or manifold gas pressure settings (see step VI).

C. IMPORTANT: If changes are made in the main spud orifice size, manifold gas pressure or primary air adjustment, change the installation data tag accordingly.

IV. PILOT FLAME ON BUT NO MAIN FLAME.

A. Check for 24V* between Electronic Control terminal **MV** and strip terminal **GND**. No voltage, Electronic Control is defective.

B. Check for 24V* between main valve terminal **MV** on combination valve and strip terminal **GND**. No voltage, defective valve wire harness. Voltage present, main gas valve operator is defective.

V. SHORT FLAME

A. Low gas pressure.

B. Primary air adjustment open too far.

C. Main spud orifice too small.

VI. LONG HAZY FLAME

A. High gas pressure.

B. Primary air adjustment closed too far

C. Dirty blower wheel.

D. Main spud orifice too large.

VII. GAS FAILS TO SHUT OFF.

A. Defective combination valve

* Normal low voltage: Burner in standby - 24V min.

Burner running (main gas valve energized) - 21V min.

GEAR MOTOR:



2416, 2418, 3018 & 4018

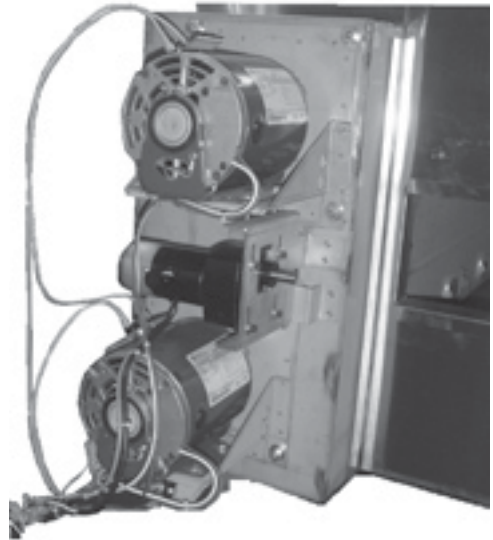

3624, 3632, 4824, 4832, 6024, 6032
4032DD & 653DD

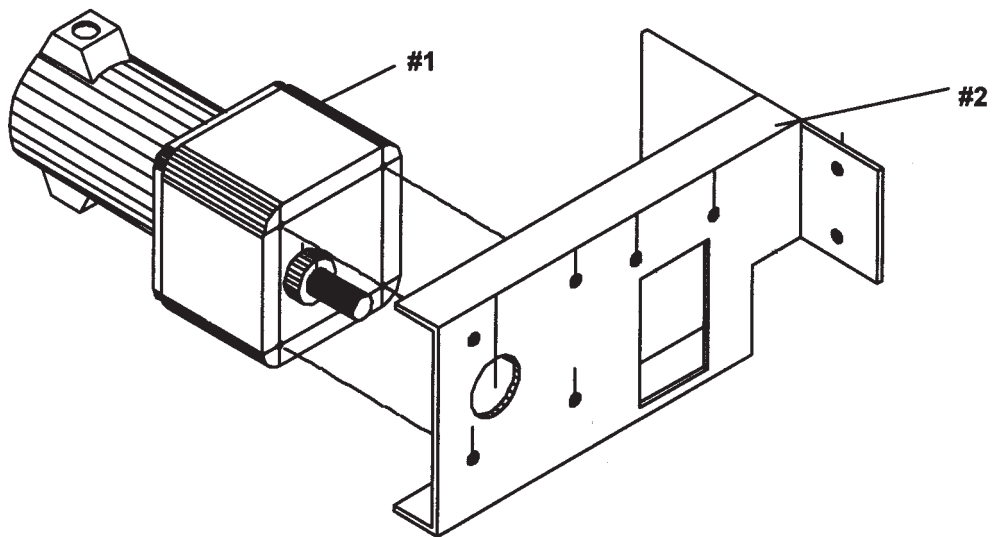

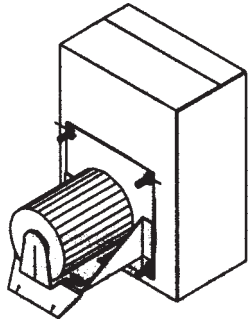

STEP #1

2416, 2418, 3018 & 4018

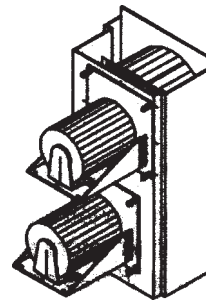

3624, 3632, 4824, 4832, 6024, 6032
4032DD & 653DD

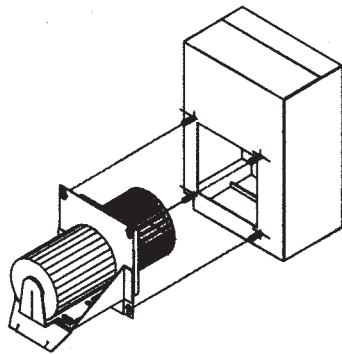

STEP #2

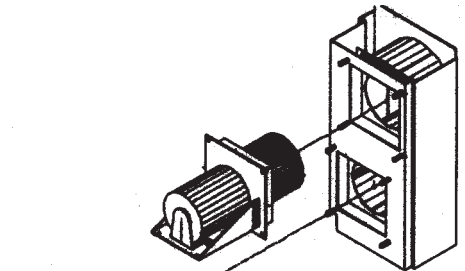

STEP #3

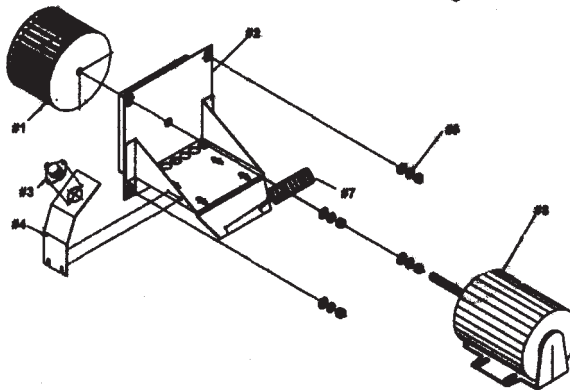

Vibrations and noises generated by the Heat Circulating Blower Motors

1. Make sure the bolts and nuts on the motor bracket are correctly fixed.
2. If everything is in place as indicated and the motor is still noisy, you will have to disassemble the motor to be able to check the blower cage: if the blower cage is not properly balanced, this could generate vibrations and noises.

Disassembling the motor:

1. Remove the chain guard of the belt.
2. Remove the chain from the gear sprocket.
3. Remove the back panel.
4. Remove the stainless steel panel.
5. Remove the locking nuts holding the blower assembly.
6. Press down on the back of the motor to disengage the bracket from the slot and pull out the blower assembly towards you.
7. Start the motor to verify the blower balance; make sure nothing will come in contact with the blower cage. If the blower cage is defective, remove it taking care to verify the exact position of the hub on the motor shaft in order to install correctly the new blower cage.

Note: An improper installation of the new blower cage which could come in contact with the outer casing would result in the immediate breakage of the blower cage.

Important: When following the procedure in reverse to reassemble the motor, ensure that all the parts are in place before using the oven.

COOLING FAN:

A cooling fan is installed on the left side, at the back of the unit. The function of this fan is to maintain the ambient temperature surrounding the motors at the proper level as recommended in the standard. It is imperative that the wire netting be kept clean and free of obstructions as this could cause the fan to stop which would result in serious damages to the air circulating motor inside the oven and would void the warranty of this product.

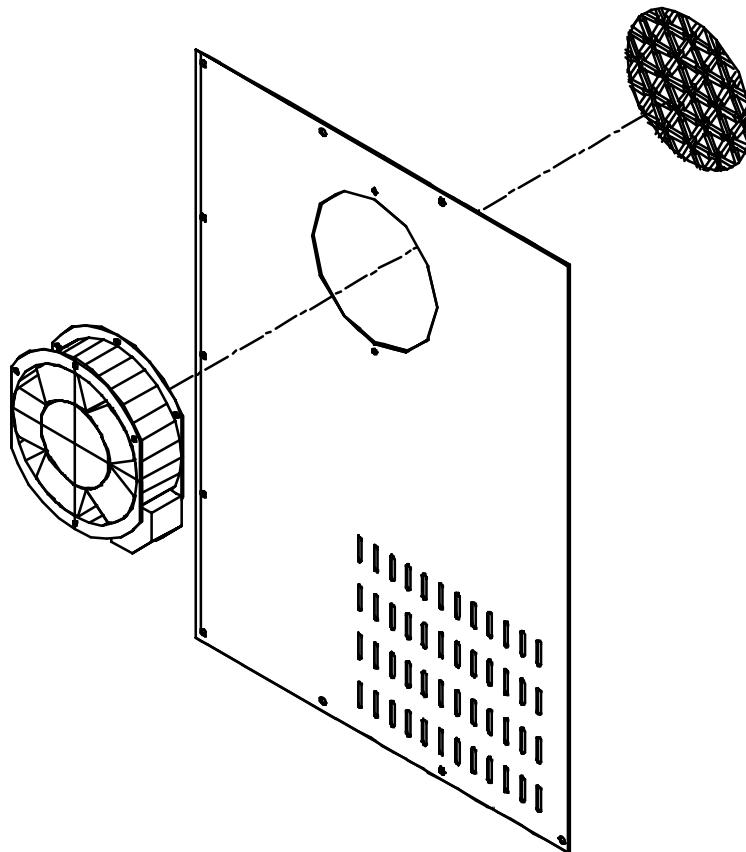

WARNING

INTAKE FANS AND SLOTS ON REAR PANELS MUST BE CLEANED WEEKLY.
ANY OBSTRUCTIONS WILL CAUSE MOTORS TO SEIZE.

AVERTISSEMENT

LES PRISES D'AIR ET LES OUVERTURES DANS LES PANNEAUX ARRIÈRES DOIVENT ÊTRE
NETTOYÉS À TOUTES LES SEMAINES.
TOUT BLOCAGE DE CES OUVERTURES PEUT FAIRE SAISIR LES MOTEURS.

Electric Diagram: 110v Gaz (ALL CONVEYOR)

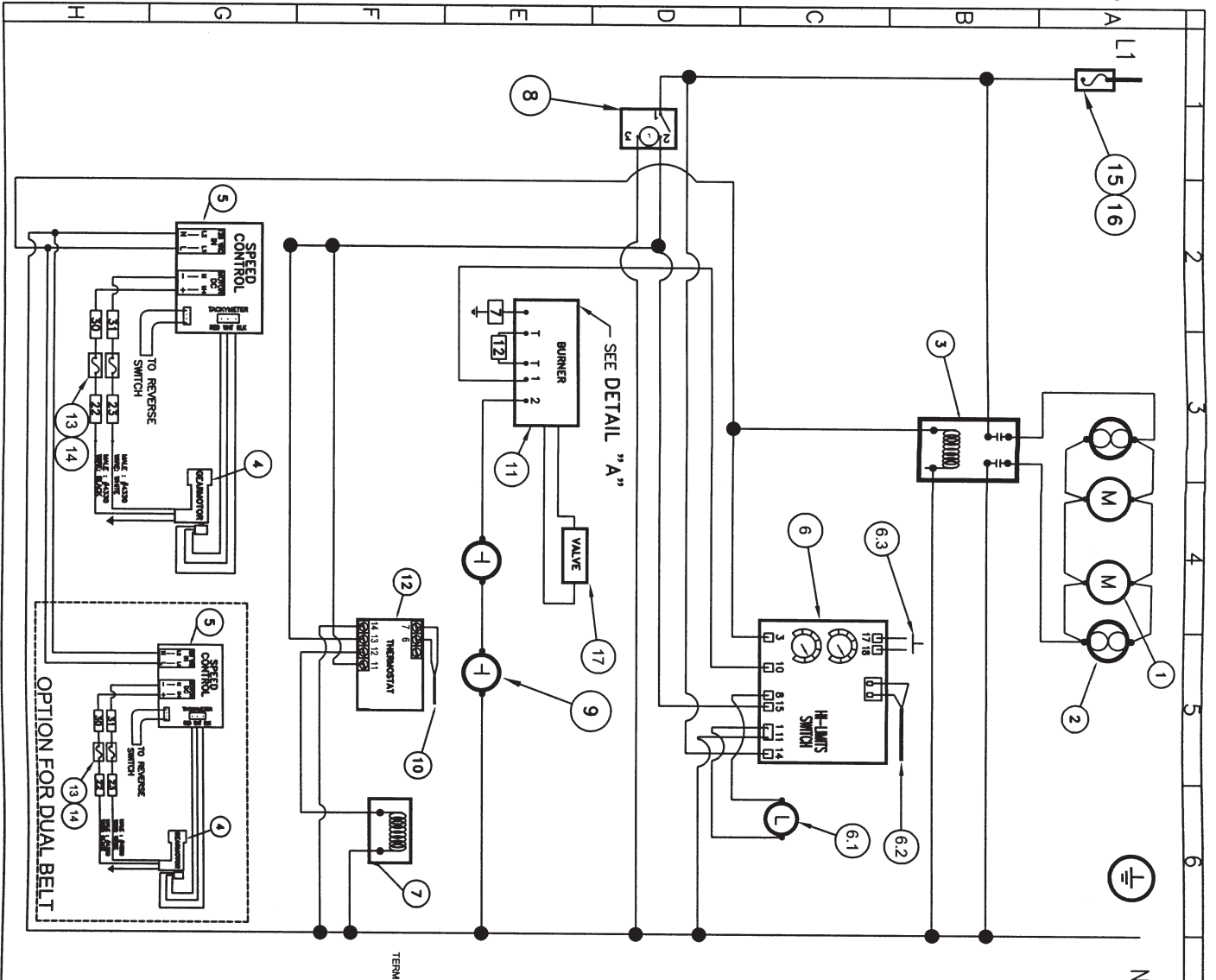

No. Qty	PART #	DESCRIPTION
1	ZG6SK435FN3729X	MOTOR HIGH TEMPERATURE
1	ZJASF0625400TLL	MOTOR BLOWER WHEEL
2	ZEL5606S	AXIAL FAN 110V
2.1	ZGR38P11	CORDSET FOR AXIAL FAN
3	ZEM9024S	CONTRACTOR 2 POLES, 30A 120 COIL
4	ZB060301790	GEARMOTOR WITH ENCODER
5	ZRA620	SPEED CONTROL BOARD
6	ZRA68S	TIME DELAY & H-LIMIT
6.1	ZRA68SNL	LAMP NEON FOR H-LIMIT
6.2	ZRA68STC	THERMOCOUPLE "C" FOR HIGH LIMIT
6.3	ZRA68SRB	RESET BUTTON FOR HIGH LIMIT
7	ZHO4295A1015	VALVE SOLENOID
8	ZNE911CRB250N	SWITCH TIPPETTE ON/OFF
9	ZEM3.01190	SWITCH TIPPETTE ON/OFF
10	ZTHK20GHTS48	THERMOCOUPLE "K"
11	ZWA64105-001(P265-AF)	WAAYNE GAS BURNER
11.1	ZWA62406-002	RELAY 24V 50-60Hz
11.2	ZWA62243-003	IGNITION CONTROL
11.3	ZWA60186-004	TRANSFORMER 120V-30VA
11.4	ZWA62245-001	HARNES WIRE .5 WIRE ASSY - 24"
12	ZDWD2001TR1DINA	THERMOSTAT ELECTRONIC
13	ZCAKHPH	FUSE HOLDER
14	ZCAMDL1	FUSE 1 AMP
15	ZCAHPS	FUSE HOLDER
16	ZCAFNMW2	FUSE 25 AMPS (MODEL: 3632, 4832 & 6032)
17	ZWA62246-004	FUSE 12AMPS (MODEL: 3018 & 4018)
17	ZWA62246-004	VALVE FOR BURNER

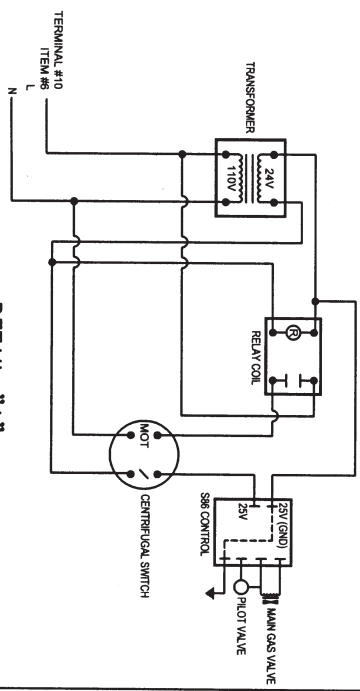

DETAIL "A"
ZOOM:

#1	ADDED OPTION FOR DUAL BELT	AUG 24, 2009	G.C.
REV.	DESCRIPTION	DATE:	OF:
DESIGN/DESIGNED	W. SILVA		
DESIGN/DRAWN	P. GORRY		
DATE	SEPT. 17, 2007		
GENERAL:	TOLERANCES:		
DEC. ±: 0.032" [1mm]	DIM. ±: 0.015" [0.5mm]		
ANG. ±: 2°	LOC. ±: 0.032" [1mm]		
	C. EN C. ±: 0.032" [1mm]		
FORM/NAME	ELECTRICAL DIAGRAM		
	GAS CONVEYOR, 110 VOLTS		
PAGE	1 OF 1		
CODE	079		
VERSION	AUG 24, 2009	DESIGN/DWG	079W

THIS DRAWING IS THE PROPERTY OF
ZESTO
FOOD EQUIPMENT MANUFACTURING INC.

CONVEYOR MODEL: CE2416/2418, CG/E3018, CG/E4018, CG/E4832/24, CG/E3632/24, CG/E4832/24 & CG/E6032/24

REV.: 2, 2008-11-14

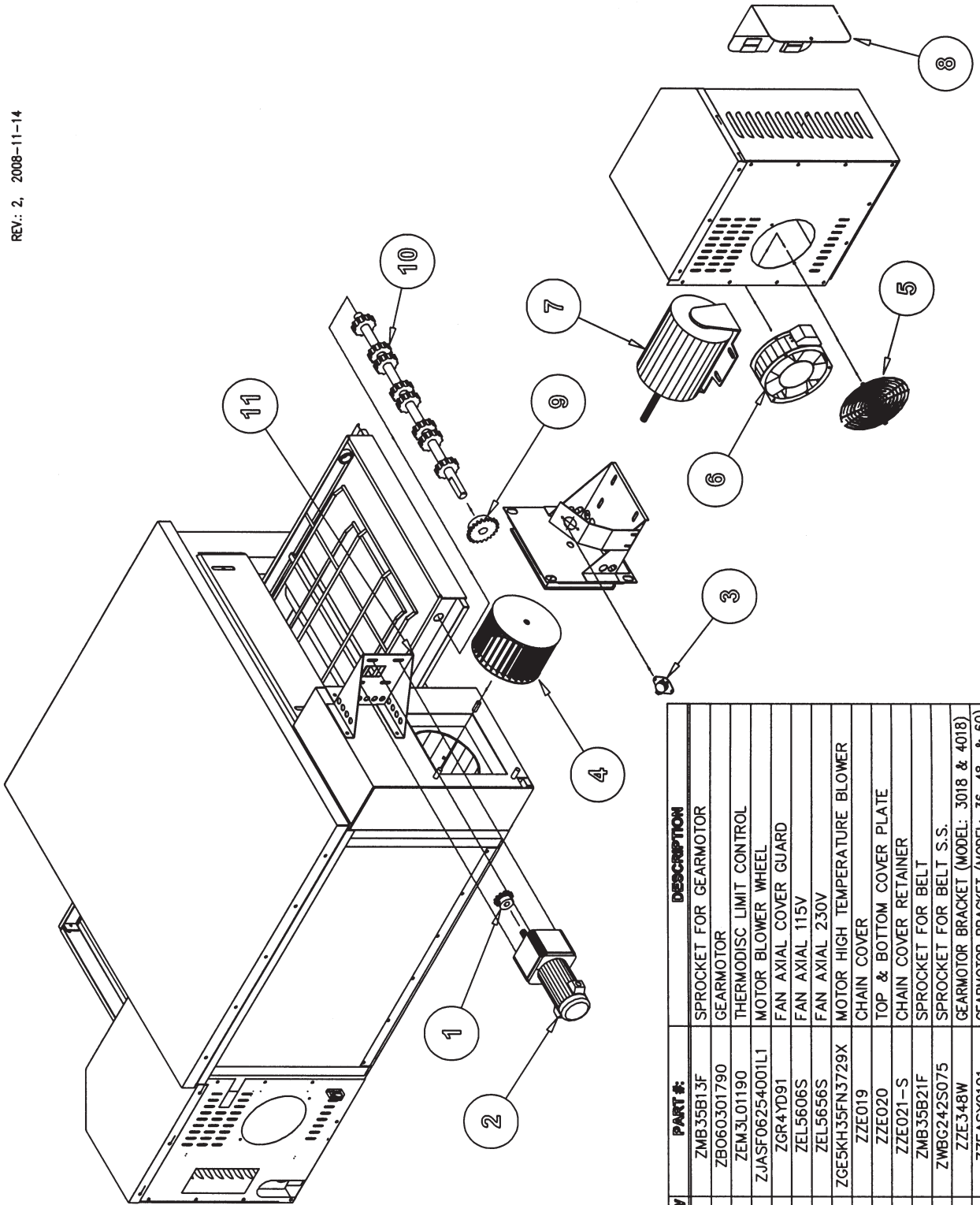

No. Qty	PART #:	DESCRIPTION
1	ZMB35B13F	SPROCKET FOR GEARMOTOR
2	ZB060301790	GEARMOTOR
3	ZEM3L01190	THERMODISC LIMIT CONTROL
4	ZJASF06254001L1	MOTOR BLOWER WHEEL
5	ZGR4YD91	FAN AXIAL COVER GUARD
6	ZEL5606S	FAN AXIAL 115V
-	ZEL5656S	FAN AXIAL 230V
7	ZGE5KH35FN3729X	MOTOR HIGH TEMPERATURE BLOWER
8	ZZE019	CHAIN COVER
-	ZZE020	TOP & BOTTOM COVER PLATE
-	ZZE021-S	CHAIN COVER RETAINER
9	ZMB35B21F	SPROCKET FOR BELT
10	ZWBG242S075	SPROCKET FOR BELT S.S.
11	ZZE348W	GEARMOTOR BRACKET (MODEL: 3018 & 4018)
-	ZZEASY0191	GEARMOTOR BRACKET (MODEL: 36, 48 & 60)
-	ZZEASY0541	GEARMOTOR BRACKET (MODEL: 2416 & 2418)

CONVEYOR MODEL: CG3018, CG4018, CG3632/24, CG4832/24, CG6032/24

REV.: 1, 2008-11-13

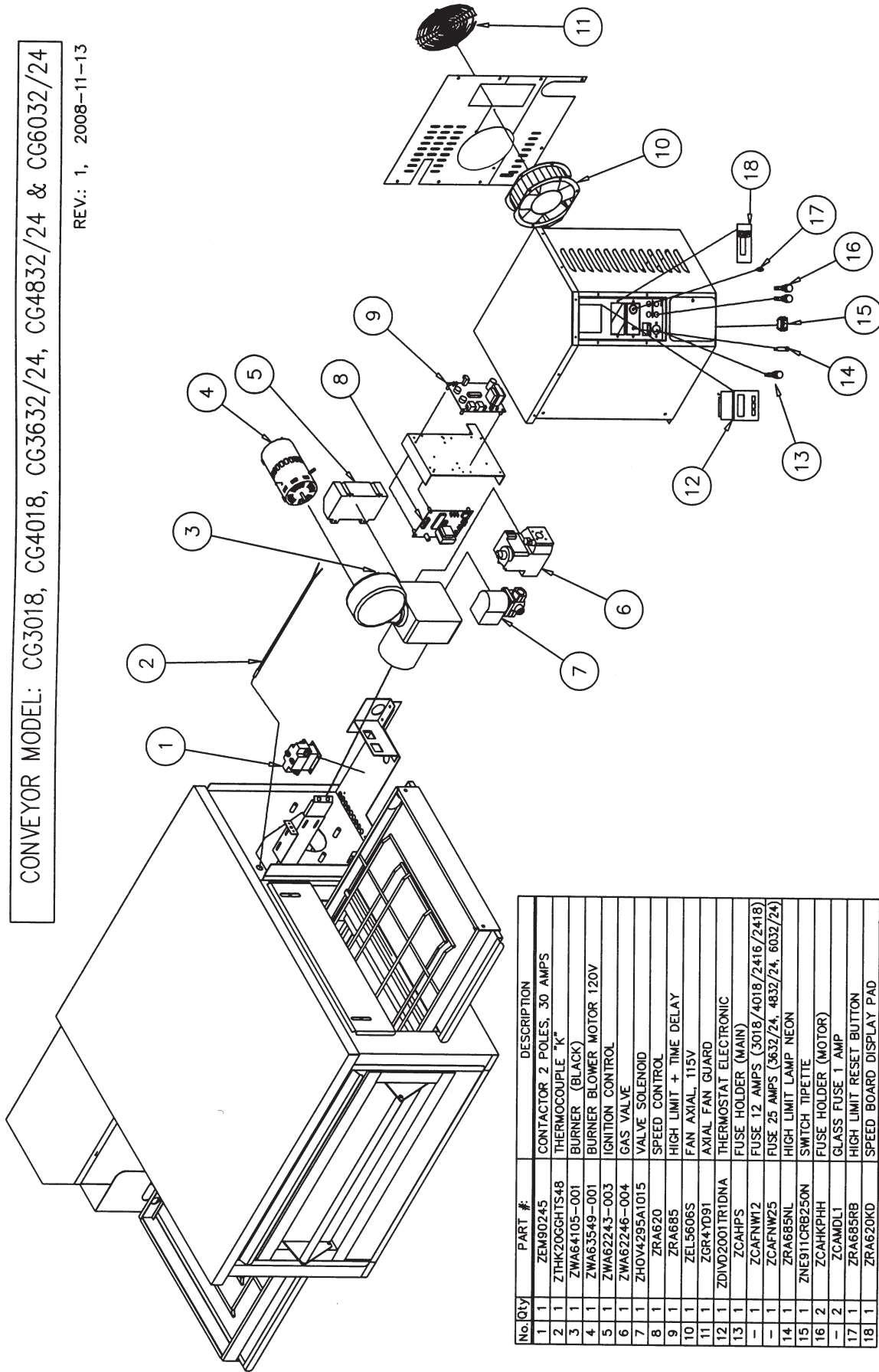

No. Qty	PART #:	DESCRIPTION
1	1	ZEM90245 CONTACTOR 2 POLES, 30 AMPS
2	1	ZTHK20GHTS48 THERMOCOUPLE "K"
3	1	ZWAG4105-001 BURNER (BLACK)
4	1	ZWAG3549-001 BURNER BLOWER MOTOR 120V
5	1	ZWAG2243-003 IGNITION CONTROL
6	1	ZWAG2246-004 GAS VALVE
7	1	ZHOV4295A1015 VALVE SOLENOID
8	1	ZRA620 SPEED CONTROL
9	1	ZRA685 HIGH LIMIT + TIME DELAY
10	1	ZEL5606S FAN AXIAL 115V
11	1	ZGR4YD91 AXIAL FAN GUARD
12	1	ZDIVD2001TRIDNA THERMOSTAT ELECTRONIC
13	1	ZCAHPS FUSE HOLDER (MAIN)
-	1	ZCAFNW12 FUSE 12 AMPS (3018/4018/2416/2418)
-	1	ZCAFNW25 FUSE 25 AMPS (3632/24, 4832/24, 6032/24)
14	1	ZRAG65NL HIGH LIMIT LAMP NEON
15	1	ZNE911CRB250N SWITCH TIPETTE
16	2	ZCAHKPHH FUSE HOLDER (MOTOR)
-	2	ZCAMDL1 GLASS FUSE 1 AMP
17	1	ZRA685RB HIGH LIMIT RESET BUTTON
18	1	ZRA620KD SPEED BOARD DISPLAY PAD

TROUBLE SHOOTING CHART

PROBLEM	POSSIBLE CAUSE	CORRECTIVE ACTION
The main switch is on and unit will not operate.	120 volts power supply or fuses defective.	Replace the fuses.
Problem remains with 120 volts power supply at terminal strip.	Defective connectors at main switch (bad connection).	Replace defective connectors.
	Defective switch.	Replace switch.
The switch is « ON » but the oven doesn't start.	Valve is at the « OFF » position.	Turn the valve to « ON ».
The burner is « ON » but the temperature doesn't rise.	The temperature controller setting is not properly adjusted.	Adjust the temperature controller.
	The thermocouple might be defective.	Check the thermocouple (see instructions in the manual).
Speed control shows «OL».	The belt is stuck.	Check the belt.
	The D.C. motor is overloaded.	Replace the motor.
Belt does not turn.	Problem with D.C. voltage supply of the Zesto speed control.	Replace the speed control.
	Gear too loose.	Tighten the allen screw of the gear.
Belt jumps.	Chain too loose.	Adjust tension of the chain.
Burner does not ignite.	Centrifugal switch does not close.	Change the burner motor.
	Gas valve does not open.	Change the valve.
	Gas valve at « OFF » position.	Turn the valve to « ON ».
Cooking is not even.	Improper adjustment of the fingers.	See instructions in the manual.
Oven gives off gas odors.	Improper adjustment of the burner flame.	See instructions in the manual.
Oven is operating, temperature controller is « ON » and the burner goes off.	Axial fan has stopped.	Replace axial fan.
	Fan circulating motor is overloaded or overheating.	Replace motor.
	Axial fan installed the wrong side (airflow going the wrong way).	Change the direction of airflow.
	Oven installed too close to the wall.	Relocate the oven.
Excessive vibrations of the circulating motor.	The blower cage is unbalanced.	Replace the blower cage.

COOKING CHART

(time & temperature will vary according to your product)

	PRODUCT	TIME approx. minutes	TEMP. (F°)/(C°)
ITALIAN	PIZZA (par baked dough)	4 to 4.5 min	510 / 265
	PIZZA (fresh dough)	5.5 to 6.5 min	510 / 265
	PIZZA (thick pan type)	7.5 to 8.5 min	510 / 265
	CALZONE (fresh dough)	5 to 6 min	510 / 265
	PASTAS (pre-cooked to gratine)	5 to 6 min	510 / 265
BREADS & SUBS	GARLIC BREAD	2.5 to 3.5 min	510 / 265
	BREAD STICKS	2.5 to 3.5 min	510 / 265
	SUBMARINE SANDWICHES	2.5 to 3.5 min	510 / 265
BAKERY	DINNER ROLLS (par baked)	4 to 4.5 min	390 / 199
	DINNER ROLLS (fresh)	7.5 to 8.5 min	390 / 199
	BAGELS (fresh)	12 to 13 min	390 / 199
	CROISSANTS (par baked)	4 to 4.5 min	390 / 199
	CROISSANTS (fresh)	9 to 10 min	390 / 199
	MUFFINS (fresh)	12 to 13 min	390 / 199
	BISCUITS & COOKIES (fresh)	4.5 to 6.5 min	390 / 199
MEAT & POULTRY	CHICKEN WINGS (pre-cooked)	5.5 to 6.5 min	510 / 265
	CHICKEN WINGS (fresh)	18 to 20 min	390 / 199
	CHICKEN BREASTS (boneless)	5.5 to 6.5 min	510 / 265
	B.B.Q. RIBS (fresh)	18 to 20 min	390 / 199
	HAMBURGER PATTIES (fresh)	5.5 to 6.5 min	510 / 265
FISH & SEAFOOD	SHRIMP (fresh)	4.5 to 5.5 min	510 / 265
	FISH FILETS (fresh)	6.5 to 7.5 min	510 / 265
	TUNA STEAK (fresh)	8.5 to 9.5 min	510 / 265
	SALMON STEAK (fresh)	6 to 7.5 min	510 / 265
MEXICAN	BURRITOS & ENCHILADAS	2.5 to 3.5 min	475 / 246
	NACHOS ASSORTED STYLES	2.5 to 3.5 min	475 / 246
EGGS	SOUFFLES & OMELETTES	5.5 to 6.5 min	510 / 265
	QUICHES	9 to 10 min	390 / 199

WARRANTY

LIMITED WARRANTY

(CANADA AND CONTINENTAL UNITED STATES OF AMERICA ONLY)

WARRANTOR WARRANTS TO THE ORIGINAL CONSUMER PURCHASER THAT THE EQUIPMENT WILL BE FREE FROM DEFECTS IN MATERIALS AND WORKMANSHIP, UNDER NORMAL USE AND SERVICE FOR A PERIOD OF ONE YEAR FROM THE DATE OF PURCHASE.

THIS WARRANTY SHALL BE VOID AND HAVE NO EFFECT IF THE EQUIPMENT IS NOT PROPERLY INSTALLED AND MAINTAINED IN ACCORDANCE WITH THE INSTALLATION INSTRUCTIONS MANUAL PROVIDED WITH THE PRODUCT.

WARRANTY LIMITATIONS

DURING THE FIRST YEAR OF THE LIMITED WARRANTY (CANADA & CONTINENTAL U.S.A. ONLY) ZESTO WILL PROVIDE REPLACEMENT PARTS AT NO CHARGE AND WILL ALSO PAY FOR REASONABLE LABOUR COSTS FOR REPAIR WORK (EXCEPT FOR REFRIGERATION, 90 DAYS LABOUR ONLY) DURING REGULAR WORKING HOURS. ALL WARRANTY REPAIRS MUST BE APPROVED BY AN AUTHORIZED COMPANY OFFICIAL BEFORE ANY WORK IS DONE. LABOUR COSTS TO BE BORNE BY ZESTO MUST NOT EXCEED THE RETAIL PRICE OF THE PARTS REPLACED.

ALL REQUESTS FOR RE-IMBURSEMENT OF CHARGES MUST BE ACCOMPANIED BY THE MODEL AND SERIAL NUMBER OF THE OVEN UNDER WARRANTY.

THE REMEDY FOR DAMAGES AS THE RESULT OF ANY DEFECTS IN THE PRODUCT WHICH HAVE BEEN WARRANTED HEREIN IS LIMITED TO REPLACEMENT PARTS AND DOES NOT INCLUDE ANY INCIDENTAL OR CONSEQUENTIAL DAMAGES OR EXPENSES SUSTAINED IN CONNECTION WITH THE PRODUCT, INCLUDING DAMAGES TO PROPERTY.

EXCEPTIONS TO WARRANTY

THIS WARRANTY DOES NOT APPLY TO DAMAGES IN TRANSIT OR DAMAGES DUE TO INCORRECT WIRING, VOLTAGE OR GAS PRESSURE; MISUSE OR ABUSE OF EQUIPMENT; FIRE; OR FAILURE TO CLEAN ACCORDING TO OUR INSTRUCTIONS.

ZESTO

FOOD EQUIPMENT MANUFACTURING INC.

MANUFACTURIER D'EQUIPEMENT EN ALIMENTATION INC.

6450 HUTCHISON, MONTREAL, QUEBEC, H2V 4C8 TEL(514)278-4621 FAX(514)278-4622

e-mail: info@zesto.ca

www.zesto.ca