



Metroflush®

Z6200 Series

Metroflush Piston-Operated Flush Valve

Installation, Operation, Maintenance and Parts Manual

Patented and Patents Pending



Models:

Z6200

Z6201

Z6203

Z6210

Metroflush Piston-Operated Flush Valve

⚠ **WARNING:** Cancer and Reproductive Harm - www.P65Warnings.ca.gov

⚠ **ADVERTENCIA:** Cáncer y daño reproductivo - www.P65Warnings.ca.gov

⚠ **AVERTISSEMENT:** Cancer et effets néfastes sur la reproduction - www.P65Warnings.ca.gov

LIMITED WARRANTY

All goods sold hereunder are warranted to be free from defects in material and factory workmanship for a period of five years from the date of purchase. Decorative finishes warranted for one year. We will replace at no costs goods that prove defective provided we are notified in writing of such defect and the goods are returned to us prepaid at Sanford, NC, with evidence that they have been properly maintained and used in accordance with instructions. We shall not be responsible for any labor charges or any loss, injury or damages whatsoever, including incidental or consequential damages. The sole and exclusive remedy shall be limited to the replacement of the defective goods. Before installation and use, the purchaser shall determine the suitability of the product for his intended use and the purchaser assumes all risk and liability whatever in connection therewith. Where permitted by law, the implied warranty of merchantability is expressly excluded. If the products sold hereunder are "consumer products," the implied warranty of merchantability is limited to a period of three years and shall be limited solely to the replacement of the defective goods. All weights stated in our catalogs and lists are approximate and are not guaranteed.

PRIOR TO INSTALLATION

Prior to installing the Metroflush® flushometer valve, install the items listed below:

- Closet fixture
- Drain line
- Water supply line

IMPORTANT:

- All Plumbing is to be installed in accordance with applicable codes and regulations.
- Water supply lines must be sized to provide an adequate volume of water for each fixture.
- Flush all water lines prior to operation (See Step 2).
- Dirt and debris can cause flush valve to run continuously.
- Sensor units should not be located across from each other or in close proximity to highly reflective surfaces.

The Metroflush® design is optimized to operate between 25 and 80 psi (172 to 552 kPa) of water pressure (running). The minimum pressure required for the valve to work properly is determined by the fixture selected. Please consult fixture manufacturer for pressure requirements. Protect the chrome or special finish of this flushometer during installation. **Do not use toothed tools to install or service the valve as this will damage the finish.**

1. Install stop valve assembly using sweat solder adapter kit if applicable. Thread sealing compounds should be used on male NPT threads only.

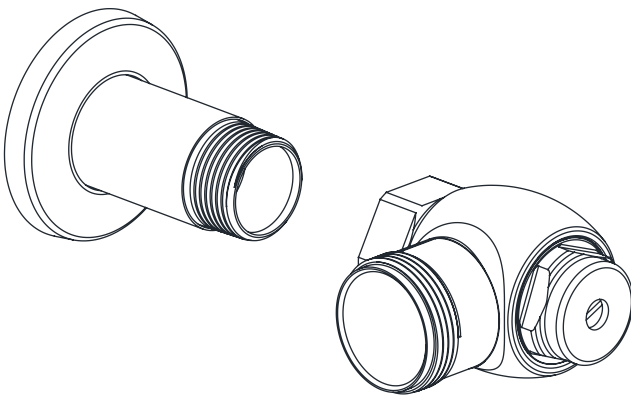

When all stop(s) are connected to the water supply and water pressure is available, flush the supply piping to remove dirt, metal chips, etc., from system.

1

- A. Before the valve is installed, open each stop fully for a brief time and catch the water in a two gallon or larger bucket. For multiple installations, start with the stop valve closest to the water supply and work toward the most remote valve.

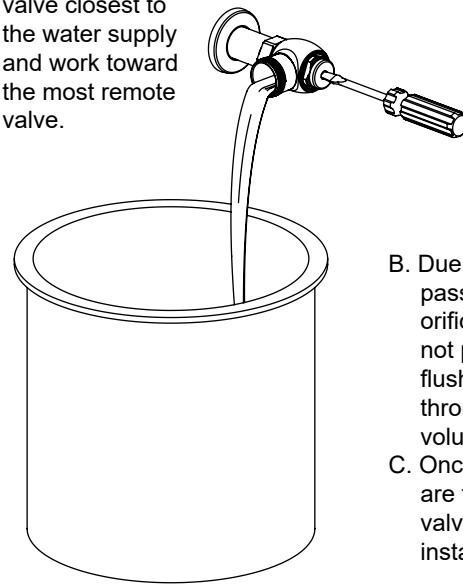

- B. Due to the small passages and orifices, it is not possible to flush the piping through the low volume valve.
C. Once the lines are flushed, the valve can be installed.

2

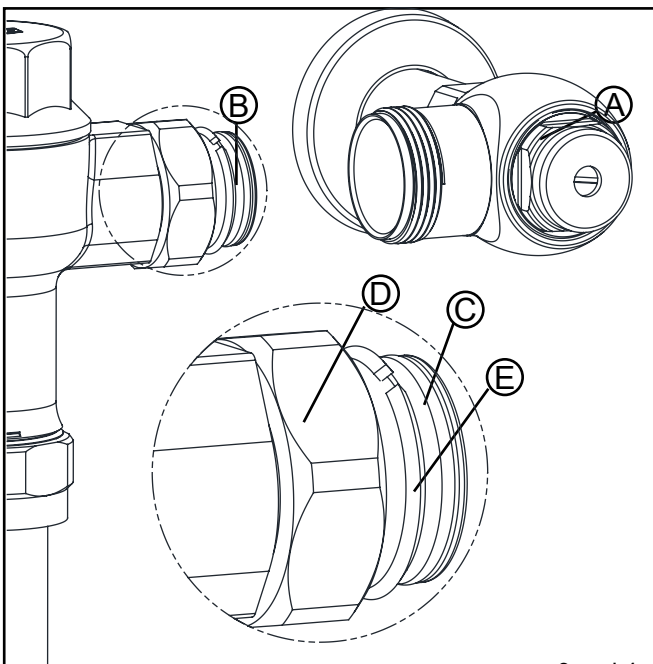

3 and 4

- 2.) Before the supply water is turned on, be sure all stop valves are closed off tight. The stop valves can be opened and closed by using the adjusting screw located at the center of the stop valve cap. Stop valve adjustments can only be made by using the adjusting screw. **It is not necessary to remove the stop valve cap when making adjustments. If for any reason it becomes necessary to remove the stop valve cap, be certain the water is shut off at the main supply valve.**

- 3.) Prior to inserting the flush valve tailpiece (B) into stop valve (A), be certain that the O-ring seal (C) is located in O-ring seal groove at the end of the tailpiece and that the locking nut (D) and locking snap ring (E) are located as shown. Care should be taken not to damage the O-ring when inserting the tailpiece into the stop valve. If lubrication is needed, wetting the O-ring with water will be sufficient.

- 4.) Insert the flush valve tailpiece (B) into the stop valve (A) and hand tighten the lock nut (D) to the stop valve. Level the entire unit.

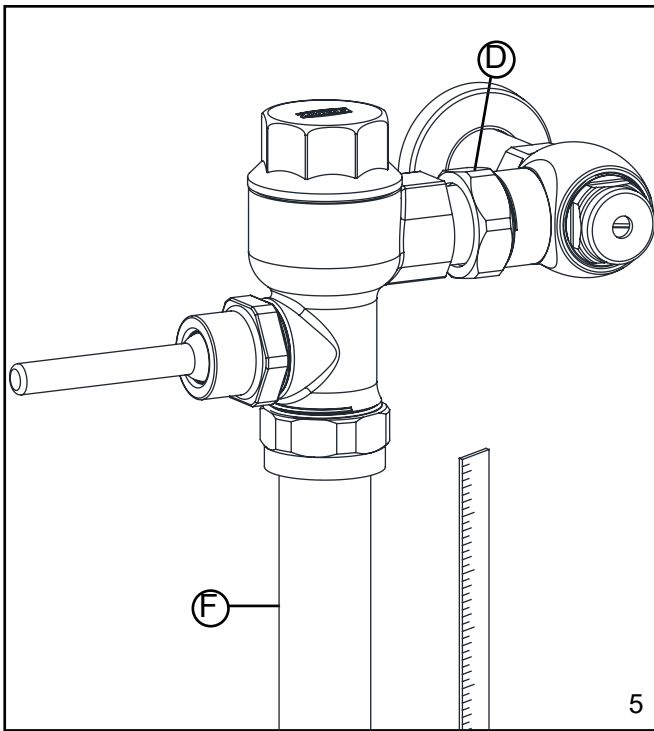

5.) Determine the length of the vacuum breaker tube (F) required to join the flush valve and fixture spud. Cut the vacuum breaker tube, if required, to this length. Assemble the vacuum breaker tube assembly and spud nut assembly to the flush valve and fixture spud.

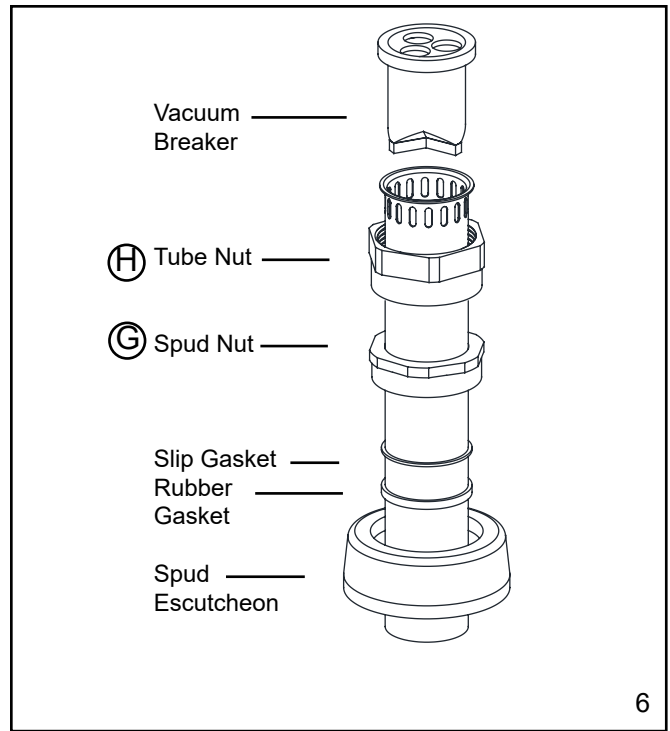

6.) Hand tighten spud nut (G) to the fixture and vacuum breaker tube nut (H) to flush valve. Adjust the valve assembly for plumb. Tighten fixture spud nut (G), vacuum breaker tube nut (H) and lock nut (D) (fig. 5) with a wrench.

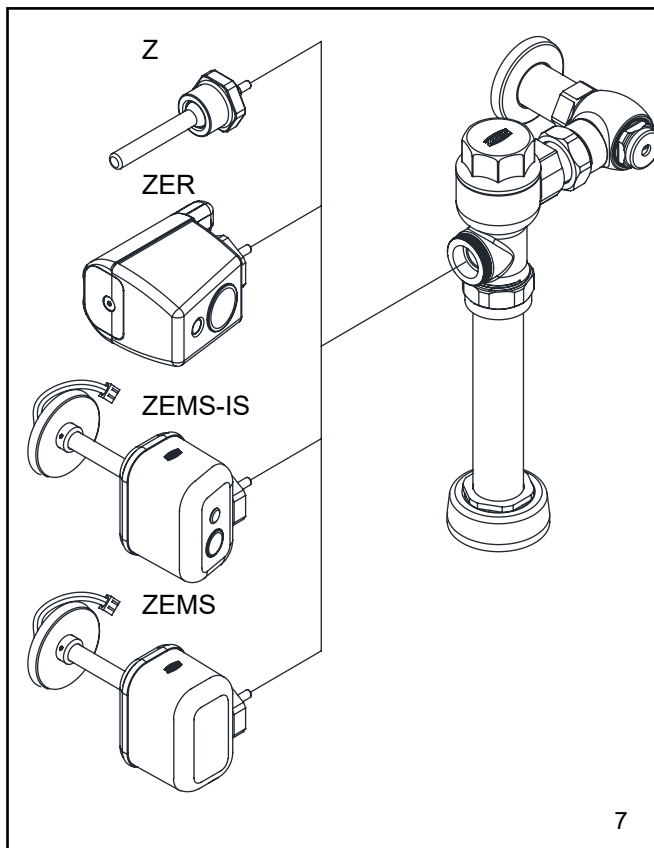

7.) Attach the appropriate handle/actuator to the valve body.

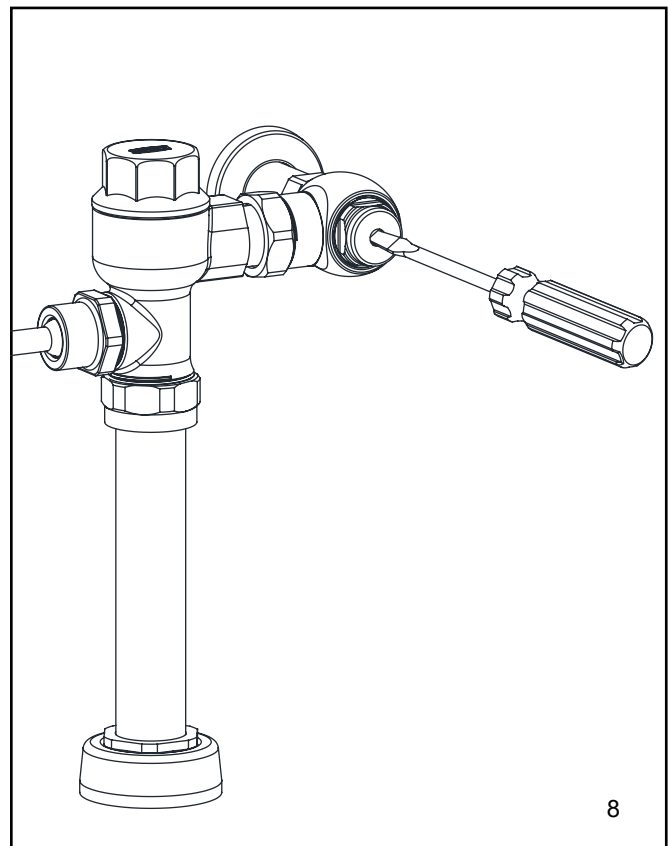

8.) Determine all flush valve connections are tight and proceed to open control stop.



Z6200 Metroflush Valve

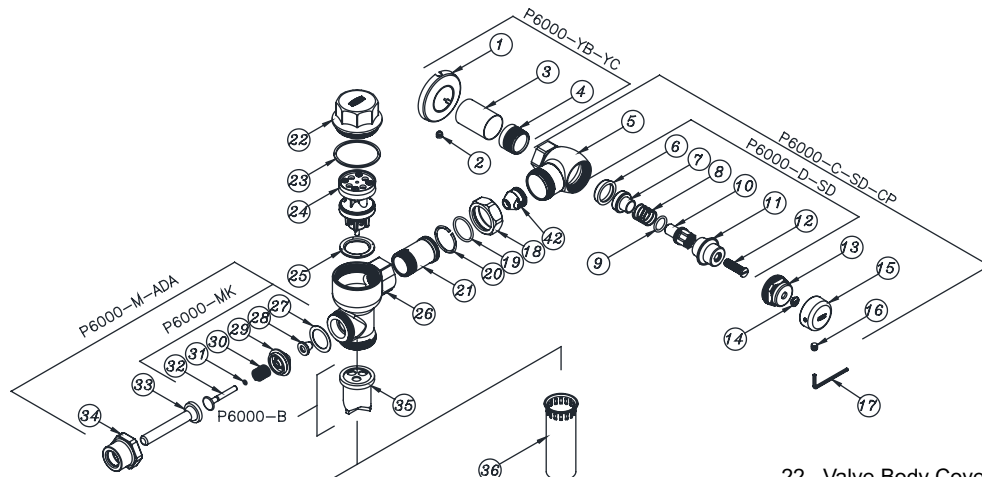

Parts Identification

1. Cast Wall Escutcheon
2. Setscrew for Cast Wall Escutcheon
3. Supply Cover Tube
4. Sweat Solder Adapter
5. Stop Body
6. Piston Seal
7. Piston
8. Stop Spring
9. Guide O-Ring
10. Piston Guide
11. Guide Holder
12. Adjusting Screw
13. Stop Cap
14. Snap Cap Screw Cover
15. Vandal-Resistant Control Stop Cover
16. Setscrew for Control Stop Cover
17. 5/64 Allen Wrench
18. Locking Nut
19. Tailpiece O-Ring
20. Snap Ring
21. Tailpiece

22. Valve Body Cover
23. Valve Body Cover Gasket
24. Internal Kit
25. Main Seat
26. Valve Body
27. Handle Gasket
28. Handle Seal
29. Handle Seal Retainer
30. Handle Spring
31. Handle O-Ring
32. Actuator Rod
33. Handle
34. Handle Nut
35. Vacuum Breaker
36. Vacuum Breaker Tube
37. Vacuum Breaker Tube Nut
38. Spud Nut
39. Spud Friction Washer
40. Spud Sleeve
41. Spud Escutcheon
42. Tailpiece filter

Covers and Repair Kits	Product No.
Outside Cover, Item 22	P6200-LL-CP
0.125 gpf Outside Cover, Item 22	P6200-LL-ULF-CP
Outside Cover O-Ring, Item 23	P6200-LL-CG
3.5 gpf Integral Repair Kit, Item 24	P6200-EC-WS
1.5 gpf Integral Repair Kit, Item 24	P6200-EU-WS
1.6 gpf Low Consumption Closet Kit, Item 24	P6200-EC-WS1
1.0 gpf Low Consumption Urinal Kit, Item 24	P6200-EU-WS1
1.28 gpf High Efficiency Closet Kit, Item 24	P6200-EC-HET
0.5 gpf High Efficiency Urinal Kit, Item 24	P6203-EU-EWS
0.125 gpf Ultra Low Flush Kit, Item 24	P6203-EU-ULF
Main Seat, Item 25	P6000-S-30
0.125 gpf Main Seat, Item 25	P6200-MS-ULF
Urinal 0.125/0.250 gpf Tailpiece filter, Item 42	PTR6203-FA-LF

Handle Assembly and Repair Kits	Product No.
ADA Handle Assembly, Items 27-34	P6000-M-ADA
Handle Repair Kit, Items 27-32	P6000-MK
Handle Seal, Item 28	P6000-M9
Handle Gasket, Item 27	P6000-M10

Control Stop Repair Kit and Parts	Product No.
Control Stop Repair Kit for 1" and 3/4", Includes Items 6-12	P6000-D-SD
Seal Seat for 1" and 3/4", Includes Item 6	P6000-D42
Sweat Solder Adapter, Includes Item 4	P6000-YBA
Vandal-Resistant Cover, Item 15	P6000-VC

Adjustable Tailpieces	Product No.
Adjustable Tailpiece, Items 19-21	P6000-J1
Tailpiece Coupling Assembly, Items 18-20	P6000-K
Tailpiece Locking Ring, Item 20	P6000-C30
Tailpiece O-Ring, Item 19	P6000-C31
Coupling Nut, Item 18	P6000-C32

Metroflush® Service Instructions

Problem	Possible Cause	Corrective Action
Valve will not operate.	1.) Stop valve is closed	1.) Open stop valve.
	2.) Supply valve is closed.	2.) Open supply valve.
Insufficient volume of water to adequately siphon fixture	1.) Stop valve is not open enough.	1.) Open stop valve for desired volume of water.
	2.) Urinal piston installed in closet valve.	2.) Replace urinal piston with proper closet piston.
	3.) Insufficient volume or pressure at supply.	3.) Consult fixture guide for minimum gallons per minute flow and running pressure for satisfactory performance.
Flush valve shuts off too quick.	1.) Damaged piston.	1.) Install new P6200-EC, P6200-EU replacement kit to remedy the problem.
	2.) Enlarged by-pass orifice.	2.) Install new P6200-EC, P6200-EU replacement kit to remedy the problem.
Valve is short flushing	1.) Enlarged by-pass orifice.	1.) Install new P6200-EC, P6200-EU replacement kit to remedy the problem.
	2.) Urinal piston installed in closet valve.	2.) Replace urinal piston with proper closet piston.
Valve is flushing too long or not shutting off.	1.) Trip mechanism not seating properly due to foreign material between trip mechanism and seat.	1.) Disassemble parts and rinse thoroughly.
	2.) By-pass orifice is plugged or partially plugged.	2.) Examine by-pass orifice and clean if necessary being certain not to enlarge orifice opening.
	3.) Line pressure is not adequate to force trip mechanism to seal.	3.) Pressure is inadequate or has dropped below minimum operating range. Steps should be taken to increase the line pressure.
Water splashes out of fixture/	1.) Supply volume is more than is necessary.	1.) Adjust downward on control stop.
	2.) Lime accumulation on vortex or spreader holes of fixture.	2.) Remove the lime build up.
Flush is not considered quiet.	1.) Control stop may not be adjusted for quiet operation.	1.) Adjust the control stop for quiet operation keeping in mind the fixture evacuation requirements.
	2.) Fixture may be contributing to noise.	2.) Check noise created by fixture by placing a cover over the bowl opening to separate valve noise from bowl noise. If it is determined the fixture is too noisy, consult with fixture manufacturer.
	3.) Piping system may be source of noise.	3.) High pressure in the system can sometimes be controlled by the stop valve. Other sources of noise may be the absence of air chamber and shock arrestors, loose pipes, improper size pipes, etc. In these cases the building engineer should be consulted.
Handle assembly leaking.	1.) 1.) Handle assembly is not tight.	1.) 1.) Tighten handle assembly.

Care of Chrome Plated Surfaces

The suggested cleaning of chrome plated surfaces is simply to clean them with soap and water then dry. Commercial cleaning compounds are never recommended.

Seasonal Use

Valves used in installations subject to shut down because of cold and freezing conditions should be maintained in the following manner. After the main supply has been shut off and the water drained from the system, remove the stop valve cap and stop internals to allow the water to drain from the flush valve itself.